

APPROVED
by the Russian National SWIFT Association
Steering Committee
September, 2012

SWIFT RUS 8

Formats and Usage Guidelines

This edition is prepared by the Russian National SWIFT Association

SWIFT-RUS

**Usage Guidelines for SWIFT standards
for financial messages exchange
in securities market with consideration of
requirements and particular features of
the Russian market**

Release 8

Table of contents

INTRODUCTION.....	7
1. General clauses.....	8
1.1 Message formats.....	8
1.1.1. MT Field Specifications	8
1.1.2. Message Type Format Specifications.....	9
1.2. ISO Identification Codes	10
1.2.1. Bank Identifier Code (BIC) of the International Organization for Standardization (ISO).....	10
1.2.2. International Securities Identification Number (ISIN) assigned by International Organization for Standardization (ISO).....	10
1.2.3. Currency Codes assigned by International Organization for Standardization (ISO)	11
1.3. Allowed character set and transliteration	11
1.3.1. Transliteration Indicator	12
1.3.2. Transliteration Rules	12
1.3.3. Transliteration Table	13
1.4. Indicator of SWIFT-RUS standards release.....	15
1.5. Message length.....	15
1.6. Message structure.....	15
1.6.1. Principles of message text creation	15
1.6.2. Message Field Types	16
1.6.3. Rules of message fields structuring.....	17
1.7. Data Types.....	17
1.8. Fields Specifications.....	18
1.8.1. Field 11A Currency.....	18
1.8.2. Field 12a Type of Financial Instrument	19
1.8.3. Field 13a Number Identification	20
1.8.4. Field 17B Flag	22
1.8.5. Field 19a Amount	23
1.8.6. Field 20C Sender's Reference (message).....	25
1.8.7. Field 20C Reference.....	26
1.8.8. Field 22a Indicator	27
1.8.9. Field 23G Function of the Message	29
1.8.10. Field 24B Reason.....	31
1.8.11. Field 25D Status	32
1.8.12. Field 28E Page number/Continuation Indicator.....	33
1.8.13. Field 35B Identification of the Financial Instrument	34
1.8.14. Field 36B Quantity.....	35
1.8.15. Field 69a Period.....	37
1.8.16. Field 70a Narrative	39
1.8.17. Field 90a Price.....	44

1.8.18.	Field 92a Rate.....	46
1.8.19.	Field 93a Balance.....	49
1.8.20.	Field 94a Place.....	50
1.8.21.	Field 95a Party.....	52
1.8.22.	Field 97a Account.....	56
1.8.23.	Field 98a Date/Time.....	58
1.8.24.	Field 99a Number	61
2.	Formats of settlement instructions	62
2.1	MT540 Receive free	62
2.1.1.	Format Specifications.....	62
2.1.2	Example of an instruction to receive securities as a result of internal movement within a Depository/Custodian	63
2.1.3.	Examples of instructions to receive securities from an account serviced by an external party	65
2.2	MT541 receive against payment.....	72
2.2.1.	Format Specifications.....	72
2.2.2.	Example of an instruction to receive securities against payment within a Depository	74
2.2.3.	Example of an instruction to receive securities against payment within a Depository-Bank.....	76
2.3	MT542 Deliver free	79
2.3.1.	Format Specifications.....	79
2.3.2.	Example of an instruction to deliver securities within a Depository/Custodian.....	81
2.3.3.	Examples of instructions to deliver securities into an account serviced by a third party	82
2.4.	MT543 deliver against payment.....	92
2.4.1.	Format Specification	92
2.4.2.	Example of an instruction to deliver securities within a Depository/Custodian.....	93
3.	Formats of confirmations of execution, statements and advices related to settlement instructions' status	96
3.1.	MT544 Receive free confirmation	96
3.1.1.	Format Specifications.....	96
3.1.2.	Example of a Receive Free Confirmation of internal transfer within a Depository/Custodian ..	98
3.1.3.	Example of a Receive Free Confirmation from an account serviced by a third party	99
3.2.	MT545 Receive against payment confirmation.....	102
3.2.1.	Format Specifications.....	102
3.2.2.	Example of a Receive Against Payment Confirmation within a Depository/Custodian	104
3.3.	MT546 Deliver free confirmation	107
3.3.1.	Format Specifications.....	107
3.3.2.	Example of a Deliver Free Confirmation of transfer from account with a Depository/Custodian 108	
3.3.3.	Example of a Deliver Free Confirmation of transfer to an account serviced by an aexternal party 110	
3.4.	MT547 deliver against payment confirmation	113
3.4.1.	Format Specifications.....	113

3.4.2.	Example of a Deliver Against Payment Confirmation of transfer from account within a Depository/Custodian	115
3.5.	MT548 settlement status and processing advice	118
3.5.1.	Format Specifications.....	118
3.5.2.	Example of MT548 - advice (receipt) of an instruction acceptance for further processing	120
3.5.3.	Example of MT548 – rejection of an instruction for further processing.....	121
3.5.4.	Examples of advices of the current matching/ settlement status of an instruction in the Depository/Custodian	122
3.6.	MT549 request for statement/status advice.....	126
3.6.1.	Format Specifications.....	126
3.6.2.	Request for Statement	127
3.6.3.	Request for Status Advice of an instruction in the Depository/Custodian	129
3.6.4.	Cancellation of the Request for Status Advice of an instruction in the Depository/Custodian ..	130
3.7.	MT535 statement of holdings	131
3.7.1.	Format Specifications.....	131
3.7.2.	Examples of MT535 Statement of Holdings.....	132
3.8.	MT536 statement of transactions	136
3.8.1.	Format Specifications.....	136
3.8.2.	Examples of MT536 Statement of Transactions	138
3.9.	MT537 statement of pending transactions	142
3.9.1.	Format Specifications.....	142
3.9.2.	Examples of Statement of Pending Transactions	145
3.10.	MT 578 Settlement Allegement	147
3.10.1.	Format Specifications.....	147
3.10.2.	Examples of Settlement Allegement	149
4.	Corporate action messages	152
4.1.	MT 564 Corporate action notification	152
4.1.1.	Format Specifications.....	152
4.2.	MT 565 Corporate action INSTRUCTION	158
4.2.1.	Format Specifications.....	158
4.3.	MT 566 Corporate action Confirmation	162
4.3.1.	Format Specifications.....	162
4.4.	MT 567 CORPORATE ACTION STATUS AND PROCESSING Advice	168
4.4.1.	Format Specifications.....	168
4.5.	MT 568 Corporate Action Narrative	171
4.5.1.	Format Specifications.....	171
5.	Corporate action messages Examples	174
5.1.1.	Example 1 Corporate action event type - Repurchase of shares according to the articles 75-76 208-Federal Law (corporate action event indicator – BIDS).....	174
5.1.2.	Example 2a. Corporate action event type - Bankruptcy (corporate action event indicator – BRUP) 185	

Example 2b. Corporate Action Type – distribution of cash as a result of liquidation (corporate action event indicator – LIQU).....	191
Example 2c. Corporate Action Type – booking out of valueless securities upon receipt of confirmation from the registrar (corporate action code – WRTH).....	193
5.1.3. Example 3. Corporate Action Type – Merger (corporate action indicator – MRGR)	195
5.1.4. Example 4. Corporate Action Type – PARI-PASSU of additional issues (corporate action event indicator – PARI)	200
5.1.5. Example 5. Corporate Action Type – Priority issue (public offer where, priority is given to existing shareholders. (corporate action event indicator – PRIO)	206
5.1.6. Example 6. Corporate Action Type – Repurchase from the shareholders their equities by the persons who owns more than 95% of the voting shares. (corporate action event indicator – TEND)	217
5.1.7. Example 7. Corporate Action Type – Booking out of worthless securities due to liquidation of the issuer (corporate action event indicator – WRTH)	223
5.1.8. Example 8. Corporate Action Type – Compilation a list of shareholders to participate in the shareholder’s meeting (corporate action event indicator – DSCL).....	226
Corporate Action Event Indicators	231

INTRODUCTION

The purpose of creating the present document is to extend the scope of opportunities of Russian S.W.I.F.T. Users, their correspondents and counterparties for using S.W.I.F.T. network for securities transactions in Russian stock market.

The present guidelines SWIFT-RUS Release 8, created by the Russian National SWIFT Association, fully comply with SWIFT message standards requirements stipulated in SWIFT User Handbook, while taking into account the features peculiar to securities transactions in the Russian securities market.

In order to achieve this goal the National Market Practice Group for elaboration of S.W.I.F.T. standards usage guidelines for Category 5 messages by the Russian National SWIFT Association defined additional rules for creating SWIFT messages related to securities transactions. With the help of such rules application of unified technology becomes possible that results in automation of messages processing for securities market transactions with taking into consideration the requirements of regulating authorities, numerous peculiar traits and matching individual practices of different financial institutions involved in exchange of Category 5 messages. The document is based on ISO 15022 standard, which is de facto international standard for electronic messages in securities markets. The authors of the document recommend to stipulate the usage of this standard in bilateral arrangements between securities market participants.

The present document should be used together with appropriate volumes of SWIFT User Handbook translated into Russian by the Russian National SWIFT Association.

This release of SWIFT-RUS 8 standards becomes effective as soon as approved by the Russian National SWIFT Association Steering Committee (November 2012).

1. General clauses

1.1 Message formats

All financial messages exchanged through S.W.I.F.T. network should conform to the formatting rules of the respective message types.

Format specifications for messages in the present Guide are based on the same scheme and the same notations as in the volumes of Standards User Handbook set.

In accordance with the decision of Securities Market Practice Group (SMPG) each message should contain the following information:

Field :20C::SEME//Reference (1.8.6).

Field :98A::SETT//Settlement Date (1.8.23).

Field :98A::TRAD//Trade Date (1.8.23).

Field :35B::Identification of the Financial Instrument specifying ISIN code (1.8.13).

Field :36B::Quantity of the Financial Instrument to be settled (1.8.14).

Field :97A: Account number and account type of the party involved in transaction (1.8.22).

Field :95a: DEAG// or :95a::REAG// Delivering Agent or Receiving Agent (it is recommended to use BIC code) (1.8.21).

Field :95a::SELL// or :95a::BUYR//client Delivering Agent or Receiving Agent (it is recommended to use BIC code) (1.8.21).

Field :95P::PSET//Place of Settlement (it is recommended to use BIC code) (1.8.21).

Field :19A::SETT// Currency code and cash amount paid (or to be paid) in exchange for the securities in the instructions to receive/delivery versus payment (1.8.5).

1.1.1.MT Field Specifications

This section describes rules which apply to the fields of a message. Description of the field, may contain some or all of the following:

FORMAT

Specifies the field formats which are allowed for the field.

PRESENCE

Indicates if the field is mandatory, optional or conditional in its sequence.

QUALIFIER

Lists the qualifiers which may be used for the field. An explanation for reading the qualifier table may be found in the “Category 5 – Securities Markets - Message Usage Guidelines”.

DEFINITION

Specifies the definition of the field in the message type.

CODES

Lists all codes available for use in the field. If there is more than one subfield for which codes are defined, each separate code list will be identified with a CODES heading. When a list of codes is validated by the network, the error code will be specified.

NETWORK VALIDATED RULES

Specifies rules that are validated on the network, that is, rules for which an error code is defined. Generally, rules specified in this section affect only the field in which they appear. In some cases, rules which are validated at the message level, i.e., rules which affect more than one field, are repeated in this section. This is the case when the rule does not affect the presence of the field, but information within several fields (eg, a currency which must be the same for more than one field in the message).

USAGE RULES

Specifies rules that are not validated on the network, that is, rules for which no error code is defined, but are nevertheless mandatory for the correct usage of the field.

This field may contain recommendations of NSMPG regarding the usage of this field, which are not validated on the network and are not mandatory for the correct usage of the message. They are intended to ensure most efficient operation with the message when conducting an operation on the securities market.

EXAMPLES

Provides one or more examples of the field as it will be formatted/used.

1.1.2. Message Type Format Specifications

Format specifications are the formatting rules for the settlement instructions, confirmations, reports and settlement status advices. This information is provided in table form for each message type:

GENERAL INFORMATION

Scope of application of the message type.

FORMAT SPECIFICATIONS

Rules for the layout of the message type.

This information is provided in table form as the following:

Status	Tag	Detailed Field Name	Content/Options	Qualifier	№ clause in RUS	№ SWIFT User Handbook
--------	-----	---------------------	-----------------	-----------	-----------------	-----------------------

Where

Status – indicates if the field is:

- **M** – Mandatory
- **O** – Optional.

The status **M** for fields in optional (sub)sequences means that the field must be present if the (sub)sequence is present and at least one field is filled in the (sub)sequence, otherwise it is not used.

Tag is the field identification.

Detailed Field Name is the detailed name of the field tag, for this message type.

Content/Options provides permitted field length and characteristics. For information concerning field structure, notation and character restrictions, please see volume “Standards MT General Information”.

Qualifier specifies the qualifier to be used in the field.

№ of section in RUS is the section number in the RUS which contains field specification

№ SWIFT User Hand book identifies the number of the field in the Field Specifications for the message type in current release of the SWIFT User Handbook..

EXAMPLES AND SCHEMES

Examples of message usage on the national securities market taking into account recommendations developed by NSMPG and corresponding schemes for securities movements.

In the message of any type it is possible to use only those fields and only those options which are provided by the format a message type.

1.2. ISO Identification Codes

1.2.1. Bank Identifier Code (BIC) of the International Organization for Standardization (ISO)

For SWIFT Users’ identification Bank Identifier Code (BIC) can be used. It is assigned in accordance with ISO standard.

FORMAT

4!a2!a2!c[3!c], where

- Bank code 4!a
- Country code 2!a
- Location code 2!c
- Branch code [3!c]

Country code is based on ISO 3166 international standard.

BIC is used in the Header of a financial message to identify its Sender and Receiver and in the text of a financial message to identify a settlement party (field 95) involved in securities transactions. For further information see Option P description.

1.2.2. International Securities Identification Number (ISIN) assigned by International Organization for Standardization (ISO)

SWIFT Users can use unified international identification codes ISIN (International Securities Identification Number) for identifying securities involved in transactions

in the stock market. These codes are assigned by a designated ISO Registration Authority – ANNA – in compliance with ISO 6166 international standard.

The structure of ISIN is the following:

FORMAT:

2!a10!c, where

- Country Code 2!a
- Security Identification Number assigned by designated authority 10!c

EXAMPLE:

:35B:ISIN RU0009046585

1.2.3. Currency Codes assigned by International Organization for Standardization (ISO)

FORMAT:

3!a

The currency code consists of two letters of ISO country code and the following third letter, indicating the specific type of currency or money. For the Russian ruble it looks like the **RUB**.

The currency code must be valid ISO code (verified by the network).

1.3. Allowed character set and transliteration

The character set allowed by S.W.I.F.T. to be used in text fields of the messages included in the present Guide is the following:

a b c d e f g h i j k l m n o p q r s t u v w x y z

A B C D E F G H I J K L M N O P Q R S T U V W X Y Z

0 1 2 3 4 5 6 7 8 9

/ - ? : () . , ' +

□Cr□ (□carriage return□) □Lf□ (□line feed□) □Space□

As the allowed character set does not contain Cyrillic characters, conversion from Cyrillic to Latin letters should be done for the purpose of financial messaging in accordance with the unified transliteration table and the rules stipulated further in this document.

The rules and transliteration table included in this section ensure the conversion from Cyrillic to Latin characters. All the messages, created by the Sender in compliance with SWIFT-RUS recommendations, that possibly contain Cyrillic letters and/or are meant to be processed by the Receiver in Russian language, must be converted.

During transliteration the upper/lower case of Cyrillic characters does not matter: all Cyrillic characters are considered as UPPER case symbols.

Transliteration should be reversible, i.e., the information before direct transliteration and after reverse transliteration must be identical (on both – Sender's and Receiver's

- sides), through which the maximum authenticity of transmitted information is guaranteed. This rule has the following exceptions: special mode of conversion of symbol «“» (double quotes) described in section 1.3.2 and impossibility of preserving the original case (register) of Cyrillic characters.

1.3.1. Transliteration Indicator

To notify the Receiver of the necessity of reverse transliteration of the whole line or its part the Sender puts transliteration indicator in the field immediately before the text that should be converted (that contains Cyrillic characters) and also after the text.

The transliteration indicator in SWIFT-RUS is apostrophe («’»). This indicator is used to notify of the start/stop of transliteration and means, that the following characters of the line in the field must be converted in accordance with the rules and the table included in the present document (during the first/odd entry) or must not be converted (during the second/even entry).

The transliteration indicator may be omitted in the end of the text under transliteration if the field does not contain more characters.

1.3.2. Transliteration Rules

Each character of the Russian alphabet should be transliterated by one appropriate character of the Latin alphabet.

In order to enlarge the Latin character set and to avoid the field size extension UPPER and lower case characters are used according to the Table of correspondence indicated below.

Service symbols are quoted unchanged except for the apostrophe («’»).

In the process of direct conversion each symbol of apostrophe («’») matches with a series of two symbols of apostrophe («’’) independently from the position of Cyrillic or Latin characters – on its right or left side.

Taking into account frequent usage of the symbol of double quotes («”») and for the purpose of its integration in the allowed character set it is considered as equivalent to the symbol of apostrophe and should be converted accordingly. In the result of reverse conversion on the Receiver’s side the symbol of double quotation in the Sender’s original text will correspond to the symbol of apostrophe in the received text.

The fields and subfields of the message’s Text block should be converted.

The following information should not be converted:

- The service part of the message (Header, Trailers, Field Tags, Field options, colons used as Field Tags separators, symbols of <Carriage return>, <Line feed>, apostrophe etc.);
- Information in the Reference field (field 20) and in the Related reference field (field 21);

- Fields containing numbers, code words or other codes according to SWIFT standards;
- Fields identifying Settlement parties with option P;
- Qualifiers;
- Code words in between two slashes.

If SWIFT-RUS transliteration is used, the following fact should be taken into account: the length of the field of the message to be sent through SWIFT network and to be transliterated together with all the service symbols of apostrophe must comply to the maximum field length in accordance with SWIFT standards.

1.3.3. Transliteration Table

Symbol of the Russian alphabet	Symbol of the Latin alphabet	Comments
А	A	
Б	B	
В	V	
Г	G	
Д	D	
Е	E	
Ё	o	Lower case
Ж	J	
З	Z	
И	I	
Й	i	Lower case
К	K	
Л	L	
М	M	
Н	N	
О	O	
П	P	
Р	R	
С	S	
Т	T	
У	U	
Ф	F	
Х	H	
Ц	C	
Ч	c	Lower case
Ш	Q	

Щ	q	Lower case
Ъ	x	Lower case
Ы	Y	
Ь	X	
Э	e	Lower case
Ю	u	Lower case
Я	a	Lower case
'	”	Apostrophe is converted into two apostrophes.
“	”	Double quotes are converted into two apostrophes.
0	0	
1	1	
2	2	
3	3	
4	4	
5	5	
6	6	
7	7	
8	8	
9	9	
((
))	
?	?	
+	+	
,	,	
/	/	
-	-	Hyphen
.	.	Dot mark
:	:	Colon
№	n	Lower case
%	p	Lower case
&	d	Lower case
Space	<Space>	

EXAMPLE 1:

The original text at the Sender's of the message side (before transliteration): 25 positions

Компания "Alliance" (ЗАО)

The text in SWIFT message (after transliteration): 30 positions

'КОМПАНИа "'Alliance"' ('ZАО)

The text at the Receiver's side (after reverse transliteration): 25 positions

КОМПАНИЯ 'Alliance' (ЗАО)

EXAMPLE 2:

The original text at the Sender's of the message side (before transliteration): 5 positions

O'Key

The text in SWIFT message (after transliteration): 6 positions

O''Key

The text at the Receiver's of the message side (after reverse transliteration): 5 positions

O'Key

1.4. Indicator of SWIFT-RUS standards release

SWIFT –RUS standards include the notion of «standard indicator» which is used together with transliteration indicator to define the release of the present document used by the Sender of the message.

This indicator is mandatory for all message types and is put in block 3 of the User Header Block in the field 113. Its format is the following: 4!x.

The standards release indicator for the version SWIFT-RUS8 is RUS8.

1.5. Message length

The maximum message length for Category 5 in compliance with ISO 15022 standard is 10000 characters.

1.6. Message structure

1.6.1. Principles of message text creation

The text of an ISO 15022 message conforms to a defined block structure. Each block consists of fields containing logically interrelated data. Main blocks may include nested blocks.

Each block starts and ends with predefined service fields that contain the name of the block:

- :16R: - start of block
- :16S: - end of block

Depending on the syntaxes rules blocks containing data of the same type may be repeated several times in the text of a message.

1.6.2. Message Field Types

The text of a message consists of two types of fields: discrete fields and generic fields.

DISCRETE FIELD

Has only one business meaning for all message types.

FORMAT:

:2!n[1!a]:<data content>, where:
:2!n[1!a]: - field tag
<data content> - information in the field

Examples of discrete fields:

:16R:GENL	start of block
:16S:GENL	end of block
:35B:	identification of the Financial Instrument
:23G:NEWM	Function of the Message
:28E:1/ONLY :	Page Number/Continuation Indicator

GENERIC FIELD

Is used to describe groups of business data that are common throughout the messages, eg, dates, amounts, settlement parties' details. They are then made unique (eg, trade date or settlement date) by the addition of a Qualifier, which gives a specific business meaning to the Field.

QUALIFIER

Is a code word of fixed length which is separated from the Field Tag by a colon «:» and from the Field Data – by double slash.

FORMAT

Generic field: :2!n1!a::4!c/[8c]/<data content>, where:

- :2!n1!a: - field tag
- :1!a: - field number and option
- : - generic field mark
- :4!c – qualifier
- [8c] - Data Source Scheme
- <data content> – field content.

EXAMPLE:1.

:97A::4!c//35x	account number
:97A::SAFE//12345	qualifier SAFE – safekeeping account
:97A::CASH//67890	qualifier CASH – cash account,

EXAMPLE:2.

:98A::4!c//8!c date
:98A::TRAD//20020810 qualifier TRAD – trade date
:98A::SETT//20020814 qualifier SETT – settlement date (according to terms and conditions of the contract).

1.6.3. Rules of message fields structuring

STRUCTURE

Each field is identified by a tag which consists of two digits followed by a letter option.

Field structure consists of a colon «:», followed by a tag, followed by a colon «:» and the field content.

CONTENT

Content and character restrictions applied to it:

Field must not start with a Carriage Return or Line Feed (<Cr><Lf>).

Field must not be entirely composed of blank characters and must consist of at least one meaningful character.

Within discrete field content a colon «:» or hyphen «-» must never be used as the first character of a line.

Fields are separated by a 'Field Separator within Text' (<Cr><Lf>).

Field content may be composed of one or several components of fixed or variable length. Subfield may be mandatory or optional.

The first field in a message is preceded by a 'Start of Text' (<Cr><Lf>) and the last field in a message is followed by an 'End of Text' (<Cr><Lf>-).

1.7. Data Types

LENGTH

nn	Maximum length
nn!	Fixed length
nn-nn	Minimum and maximum length
nn*nn	Maximum number of lines times maximum line length

TYPES OF CHARACTERS

n	numeric (0-9) only
a	alphabetic capital letters (A-Z)
c	alpha-numeric capital letters (upper case) and digits only
x	any character of the X permitted set
e	blank or space
d	The integer part must contain at least one digit. A decimal comma is mandatory and is included in the maximum length.. Punctuation marks or blanks, are not permitted within the integer part or decimal part.

BRACKETS

[] Optional subfield

{ } Block separator

“X” PERMITTED CHARACTER SET

a-z A-Z 0-9 - / : () . , ‘ + ? <CrLf> <Space>

CODE WORDS AND QUALIFIERS

Upper case alphabetic letters and digits only.

1.8. Fields Specifications

The following general rules apply to all fields:

The field length and type of characters are specified in the field specifications for individual message types.

Unless otherwise stated, all specified subfields must be present.

Brackets, [], around the format of a particular subfield, indicate that the subfield is optional within that field. For example, if the format for a field is ‘16x[/4x]’, up to 16 characters must be present. The following 4 characters, preceded by a slash ‘/’, are optional, and therefore may not be present in the field.

A field format may be shown on two or more lines, if the field contains several lines the field format should contain number of lines and the maximum allowable number of characters with “*”: 10*35x, 6*35x, 4*35x etc.

EXAMPLE:

:95Q::4!c//4*35x, i.e.,

:95Q::BUYR//HONGKONG SECURITIES
EXCHANGE SQUARE 3
CENTRAL HONG KONG

or

:95P::4!c//4!a2!a2!c[3!c], i.e.,

:95P::DEAG//SBOSUS3N

1.8.1. Field 11A Currency

FORMAT

Option A	:4!c//3!a	(Qualifier) (Currency Code)
Qualifier	4!c	
Currency Code	3!a	

PRESENCE

Optional

QUALIFIER

ACCT	Currency of Account	Base currency of the account.
DENO	Currency of Denomination	Currency in which a financial instrument is currently denominated
FXIB	Currency to Buy	Account servicer is instructed to buy the indicated currency after the receipt of cash proceeds.
FXIS	Currency to Sell	Account servicer is instructed to sell the indicated currency in order to obtain the necessary currency to fund the transaction within this instruction message.
OPTN	Currency Option	Currency in which the cash disbursed from an interest or dividend payment is offered.

DEFINITION

The field contains information about the currency code. This field is used both for the settlements and reports on the settlements, and for Corporate Action messages.

NETWORK VALIDATED RULES

Currency Code must be a valid ISO 4217 currency code (Network Validated Rules).

EXAMPLES

:11A::DENO//EUR currency of denomination of financial instrument
:11A::OPTN//USD cash payment is done in US dollars

1.8.2. Field 12a Type of Financial Instrument

Option A	:4!c/[8c]/30x	Qualifier)(Data Source Scheme)(Instrument Code or Description)
Option B	:4!c/[8c]/4!c	(Qualifier) (Data Source Scheme) (Instrument Type Code)
Option C	:4!c//6!c	(Qualifier) (CFI code)

where

- Qualifier 4!c
- Data Source Scheme [8c]
- Instrument Type Code 30x
- Instrument code or
- Description 4!c
- CFI code 6!c

PRESENCE

Optional

DEFINITION

The field can be used in both in settlements messages and settlements reconciliation, as well as in Corporate Action messages:

The fields indicates the following information:

- Classification Type of the financial instrument / qualifier CLAS /,
- Option Style /OPST/,
- Option Type /OPTI/.

Classification type

Classification type of the financial instrument, for example, ISO Classification of Financial instrument (CFI).

Option Style_Specifies how an option can be exercised (American or European).

Option Type

Specifies whether it is a call option or a put option.

USAGE RULES

In option B if Data Source Scheme is not present, Instrument Type Code must contain one of the following codes:

Option style – AMER (American Style) or EURO (European Style).

Option type – CALL (Call Option) or PUTO (Put Option).

When option C is used, CFI code must contain a valid ISO CFI code.

EXAMPLES

- | | |
|----------------------|--|
| :12A::CLAS/ECLR/BOND | Classification Type of financial instrument code is indicated with Euroclear Data Source Scheme. |
| :12B::OPST//AMER | Specifies how an option can be exercised |
| :12C::CLAS//ESVUFR | CFI code classification type |

1.8.3. Field 13a Number Identification

FORMAT

- | | | |
|----------|---------------|---|
| Option A | :4!c//3!c | (Qualifier) (Number ID) |
| Option B | :4!c/[8c]/30x | (Qualifier) (Data Source Scheme) (Number) |
| Option J | :4!c//5!c | (Qualifier) (Extended Number ID) |

where

- Qualifier 4!c
- Number ID 3!c

- Extended Number ID 5!c
- Number - XML message identifier 30x

PRESENCE

Optional

QUALIFIER

The field can be used in both in settlements messages and settlements reconciliation, as well as in Corporate Action messages:

It is recommended to use the following qualifiers:

CAON	CA Option Number	Number identifying the available corporate action options assigned by account servicing institution (used in the Corporate Action messages).
COUP	Coupon Number	Number of the next coupon attached/associated with a security.
LINK	Linked Message	Message type number/message identifier of the message referenced in the linkage sequence.
LOTS	Lot Number	Number identifying a lot constituting the financial instrument.
POOL	Pool Number	Number identifying a group of underlying assets assigned by the issuer of a factored security.
STAT	Statement Number	Sequential number assigned to the statement.
VERN	Version Number	Version number of the option contract or tranche of the related financial instrument.

Possibility of using a specific code is determined in the message specification.

DEFINITION

This field specifies the message type number of the related message as well as the sequential number of the report, assigned by the sender.

NETWORK VALIDATED RULES

Extended number identification is only used in change reports (DELT code). Reference number in Option B must not start or end with a slash «/» and not contain two consecutive slashes «//».

USAGE RULES

With qualifier LINK Number ID must contain the FIN message type number of the linked message.

EXAMPLES

:13A::LINK//540 Message type number of the linked message

:13A::STAT//364 Statement Number of the report

:13A::CAON//002 Corporate Action Option Number

1.8.4. Field 17B Flag

FORMAT

Option B :4!c//1!a (Qualifier) (Flag)

where

- Qualifier 4!c
- Flag 1!a

PRESENCE

Optional

QUALIFIER

It is recommended to use the following qualifiers:

ACTI	Activity Flag	Indicates whether holdings or transactions are reported in this statement
AUDT	Audited statement	Indicates whether the statement is audited.
CALL	Callable Flag	Indicates whether the issuer has the right to repay the financial instrument prior to maturity (used in the Corporate Action messages).
CERT	Certification/ Breakdown Flag	Indicates whether certification/breakdown is required. (providing information about the owner of the securities)
CONS	Sub-safekeeping Statement	Indicates whether the statement reports holdings or transactions at sub-safekeeping account level.
CHAN	Change Allowed Flag	Indicates whether change of instruction is allowed.
DFLT	Default Processing Flag	Indicates whether the option, for example, currency option, will be selected by default if no instruction is provided by the account owner. (used in the Corporate Action messages)
FRNF	Floating Rate Note Flag	Indicates whether the interest rate of an interest bearing instrument is reset periodically. (used in the messages for corporate actions)
PUTT	Puttable Flag	Indicates whether the holder has the right to ask for redemption of the financial instrument prior to final maturity (used in the Corporate Action messages).
RCHG	Charges Flag	Indicates whether charges apply to the holder, for instance redemption charges. (used in the Corporate Action messages)
STIN	Standing Instruction Flag	Indicates whether an account owner has placed a standing order to select this corporate action option. (used in the Corporate Action

WTHD	Withdrawal Allowed Flag	messages) Indicates whether withdrawal of instruction is allowed. (used in the Corporate Action messages)
------	-------------------------	--

DEFINITION

This field specifies the flag of information availability in the report, such as the balances or transactions on the account, as well as the type of the statement.

Corporate Action messages may contain the following information: whether certification from the account holder is required (providing information about the owner of the securities), changes of the interest rate on interest-bearing financial instrument, whether the holder has the right to ask for redemption of the financial instrument prior to final maturity, whether the issuer has the right to repay the financial instrument prior to maturity.

CODES

Subfield Flag must contain one of the following codes:

N	No
Y	Yes

USAGE RULES

If the Activity Flag (field:17B::ACTI) indicates no information to be reported, that is, N, then subsequences Financial Instrument or Transactions must not be present in the message.. Otherwise, they are mandatory.

If the consolidated statement flag (field:17B::CONS) is set to «Y», then in each sequence of «Sub-safekeeping account» should be given the appropriate number of sub-accounts.

Qualifier AUDT is optional.

EXAMPLES

:17B::ACTI/N	the report does not contain information
:17B::CONS/Y	consolidated statement contains information on sub-accounts
:17B::DFLT/Y	by-default option (if there are no instructions from the owner of the account)
:17B::RCHG/Y	commission is charges form the owner of the account

1.8.5. Field 19a Amount

FORMAT

Option A :4!c//[N]3!a15d (Qualifier) (Sign) (Currency code) (Amount)

where

- Qualifier 4!c
- Negative amount sign [N]
- ISO currency code 3!a

PRESENCE

Optional

QUALIFIER

It is recommended to use the following qualifiers in the messages on settlements and corporate actions:

ACRU	Accrued Interest Amount	Amount of interest that has been accrued in between coupon payment periods.
BOOK	Book Value	The cost of all securities. This is needed for tax purposes in some countries.
CHAR	Charges/Fees	Amount of money paid for the provision of financial services that cannot be categorised by another qualifier.
COVA	Value of Collateral Held	Total value of the collateral (post-haircut) held by the exposed party prior to the collateral proposal.
DEAL	Trade Amount	Principal amount of a trade (price multiplied by quantity) or Principal amount of a trade (for second leg).
ENTL	Entitled Amount	Cash amount based on terms of corporate action event and balance of underlying securities, entitled to/from account owner (which may be positive or negative).
ESTT	Settled Amount	Amount effectively settled and which will be credited to/debited from the account owner's cash account. It may differ from the instructed settlement amount (SETT) based on market tolerance level.
HOLD	Holding Value	Value of an individual financial instrument holding within a safekeeping account.
LOCO	Local Tax	Amount of tax charged by the jurisdiction in which the financial instrument settles.
PSTA	Posting Quantity	Quantity of securities that have been posted (credit or debit) to safekeeping account.
REGF	Regulatory Amount	Amount of money charged by a regulatory authority, for example, Securities and Exchange fees in US.
SETT	Settlement Amount	Total amount of money to be paid or received in exchange for the financial instrument.
STAM	Stamp Duty	Amount of stamp duty.
STEX	Stock Exchange Tax	Amount of stock exchange tax.
TRAN	Transfer Tax	Amount of tax levied on a transfer of ownership of financial instrument.
TRAX	Transaction Tax	Amount of transaction tax.
VATA	Value-Added Tax	Amount of value added tax.
WITH	Withholding Tax	Amount of money that will be withheld by a tax authority.

DEFINITION

This field specifies the total amount of funds effectively settled (ESTT) to be paid or received in exchange for the financial instrument. (SETT) .

In Corporate Action messages the field may specify the amount entitled to the owner (ENTL), the gross amount of funds (GRSS), Withholding Tax Amount (TAXR), etc.

USAGE RULES

The maximum length is 15 characters, including a comma between the integer and fractional part.

The integer part of Amount must contain at least one digit. A decimal comma is mandatory and is included in the maximum length. Punctuation marks or blanks, are not permitted within the integer part or decimal part..

The field must not be empty or start with zero, only if zero is indicated in the integer part of the amount followed by a comma.

Sign N must be present only for the negative amount.

Currency Code must be a valid ISO currency code (validated on the network).

The field can be used in both in settlements messages and settlements reconciliation, as well as in Corporate Action messages:

Settlement Amount / qualifier SETT/,

Amount Effectively Settled / qualifier ESTT/,

Accrued Interest Amount / qualifier ACRU/,

Transaction Amount / qualifier DEAL/,

Executing Broker's Amount/ Commission / qualifiers EXEC, LOCO/,

Tax Amount / qualifier COAX, STAM, STEX, TRAN, TRAX, VATA, WITH etc./

Interest Amount / qualifier INTR/.

EXAMPLES

:19A::SETT//USD1000

:19A::ESTT//USD1000

:19B::ENTL//RUB750000 Entitled Amount payable to the owner

:19B::GRSS//RUB1000000 gross cash amount

:19B::NETT//RUB750000 Net Cash Amount

:19B::TAXR//RUB180000 Withholding Tax Amount

1.8.6. Field 20C Sender's Reference (message)

FORMAT

Option C :4!c//16x (Qualifier) (Reference)

where

- Qualifier 4!c

- Message reference 16x

PRESENCE

Mandatory

QUALIFIER

It is recommended to use the following qualifiers in the settlement and corporate action messages:

SEME - Reference assigned by the Sender to unambiguously identify the message.

DEFINITION

This field specifies reference of the message assigned by the Sender to unambiguously identify the message.

NETWORK VALIDATED RULES

Reference must not start or end with a slash «/» and not contain two consecutive slashes «//».

USAGE RULES

It is recommended to indicate unique reference to unambiguously identify the message.

EXAMPLES

:20C::SEME//INST1425

1.8.7. Field 20C Reference

FORMAT

Option C :4!c//16x (Qualifier) (Reference)

where

- Qualifier 4!c
- Linked message Reference/Corporate Action Reference 16x

PRESENCE

Mandatory in an optional sequence

QUALIFIER

It is recommended to use the following qualifiers in settlements and Corporate Action messages:

COAF	Official Corporate Action Event Reference	Official and unique reference assigned by the official central body/ entity within each market at the beginning of a corporate action event.
CORP	Corporate Action Reference	Reference assigned by the account servicer to unambiguously identify a corporate action event. Should remain unchanged in all correspondence between the sender of the message and its recipient
PREV	Previous Message	Message reference of the linked message

	Reference	which was previously sent.
RELA	Related Message Reference	Message reference of the linked message which was previously received.
SEME	Sender's Message Reference	Reference assigned by the Sender to unambiguously identify the message.

DEFINITION

This field may contain the reference of the message linked with the current instruction, reference of the message being canceled, a reference of the corporate action notification or corporate action reference (the reference assigned by custody or Official Corporate Action Event Reference assigned by official body on the market).

NETWORK VALIDATED RULES

Reference must not start or end with a slash «/» and must not contain two consecutive slashes «//».

USAGE RULES

To cancel a previously sent message, Function is CANC. Reference (field 20C) in the linkage sequence must contain the Sender's reference of the message to be cancelled. In a cancellation request message a copy of at least the mandatory fields of the message to be cancelled must be present.

EXAMPLES

:20C::RELA//INST1425

1.8.8. Field 22a Indicator

FORMAT

Option F	:4!c/[8c]/4!c	(Qualifier) (Data Source Scheme) (Indicator)
Option H	:4!c//4!c	(Qualifier) (Indicator)

where

- Qualifier 4!c
- Data Source Scheme [8c]
- Indicator 4!c

PRESENCE

Presence of the fields (mandatory or optional) and a list of valid qualifiers are indicated in Format Specifications of a particular message, depending on the sequence /subsequence and the type of indicator.

QUALIFIER

It is recommended to use the following qualifiers in the settlement and Corporate Action messages:

BENE	Beneficial Ownership Indicator	Specifies whether there is change of beneficial ownership.
BLOC	Block Trade Indicator	Specifies whether the settlement instruction is

CAEP	Corporate Action Event Processing	a block parent or child. Type of processing involved by a Corporate Action.
CAEV	Corporate Action Event Indicator	Specifies the type of corporate event.
CAMV	Mandatory/ Voluntary Indicator	Specifies whether the event is mandatory, mandatory with options or Voluntary and if the instruction is required.
CASY	Cash Settlement System Indicator	Specifies what cash settlement system is instructed to be used.
CCPT	CCP Eligibility Indicator	Specifies whether the settlement transaction is CCP (Central Counterparty) eligible.
CODE	Complete/Updates Indicator	Specifies whether the statement is complete or contains changes only. (used in statements – specifies whether the statement contains complete data or only changes since the previous statement)
CONV	Conversion Type Indicator	Specifies the conversion type instrument (used in corporate action messages)
CRDB	Credit/Debit Indicator	Specifies whether the value is a debit or credit.
DISF	Disposition of Fractions Indicator	Specifies how fractions resulting from derived securities will be processed or how prorated decisions will be rounding, if provided with a pro ration r ate.
ESTA	Corporate Action Event Stage	Stage in the corporate action event life cycle.
MICO	Method of Interest Computation Indicator	Specifies the computation method of (accrued) interest of the financial instrument.
NETT	Netting Eligibility Indicator	Specifies whether the settlement transaction is eligible for netting.
PAYM	Payment Indicator	Specifies whether the instruction is free or against payment.
REDE	Receive/Deliver Indicator	Specifies whether the transaction is a receipt or delivery of financial instruments.
REGT	Registration Indicator	Specifies whether registration should occur upon receipt.
REPT	Repurchase Type Indicator	Specifies the type of repurchase transaction.
REST	Restrictions	Specifies the regulatory restrictions applicable to a financial instrument.
RTGS	Securities Real-Time Gross Settlement Indicator	Specifies whether the settlement transaction is to be settled through an RTGS or a non RTGS system.
SETR	Type of Settlement Transaction Indicator	Specifies underlying information regarding the type of settlement transaction (REPO transaction, issuance, depositary receipts issuance, etc.
SETS	Settlement System/ Method Indicator	Specifies whether the settlement instruction is to be settled through the default or the alternate settlement system.

SFRE	Statement Frequency Indicator	Specifies frequency of a statement (used in the statements - to specify frequency of a statement / daily, monthly, etc.)
STAM	Stamp Duty Indicator	Specifies the stamp duty type or exemption reason applicable to the settlement instruction.
STBA	Statement Basis	Specifies the type of balances on which the statement is prepared. (used in statements – to specify the type of balances on which the statement is prepared – by trade date, by contractual date, or by effective settlement date)
STCO	Settlement Transaction Condition Indicator	Specifies the conditions under which the order/trade is to be settled. (used to specify additional special conditions)
STTY	Statement Type	Specifies the usage purpose of the statement of holding. (used in statements – to specify if the statement is custody or it contains market valuation of securities portfolio)
STST	Statement Structure Type Indicator	Specifies whether the statement is sorted by status or transaction.
TCPI	Tax Capacity Party Indicator	Specifies the tax role capacity of the instructing party.

DEFINITION

This field contains additional indicator, e.g., type of securities, settlement conditions, type of settlement instruction etc.

USAGE RULES

In SETDET sequence this field specifies the type of settlement transaction. Code SETR//TRAD is recommended to be used as default for all transaction types. Standard codes (OWNI, OWNE) may also be used if bilaterally agreed by the parties.

EXAMPLES

:22F::CAMV//VOLU

:22F::CAEV//DVCA

1.8.9. Field 23G Function of the Message

FORMAT

Option G 4!c[/4!c] (Function) (Subfunction)

where

- Function of the message 4!c
- Subfunction of the message [/4!c]

PRESENCE

Mandatory

DEFINITION

This field identifies the function of the message.

CODES

“Function” field may contain one of the following codes depending on the message type:

CANC	Cancellation Request	Message requesting the cancellation of a previously sent message.
PREA	Preadvice	Relates to a pre-advice, that is for matching purposes only. It can be used for matching but is not binding prior to the corresponding instructions from the account owner
ADDB	Additional Business Process	Message sent to notify an additional business process to a corporate action.
CANC	Cancellation Advice	Message to cancel a corporate action event previously announced by the account servicer or a previously sent Preliminary Advice of Payment message (:22F::ADDB//CAPA in sequence D).
NEWM	New	New message.
REPE	Eligible Balance Notification	Message reporting an eligible balance that may or may not include an entitlement calculation or a revised entitlement calculation. It may (optional) include calculation of payable receivables or changes in calculation of payable receivables (used in the Corporate Action messages)
REPL	Replacement	Message replacing a previously sent message (used in Corporate Action messages)
RMDR	Reminder	Message sent as a reminder of an event taking place. (used in the Corporate Action messages to remind of necessity to send instructions on voluntary corporate action or with the right of choice)
WITH	Withdrawal	Message sent to void a previously sent notification due to the withdrawal of the event or offer by the issuer.
CAST	Cancellation Request Status	Message reporting on a cancellation request status.
EVST	Event Status	Message reporting on a corporate action event status.
INST	Instruction Status	Message reporting on an instruction status.
CODU	Copy Duplicate	Message is a copy to a party other than the account owner/account servicer.

COPY	Copy	Message is a copy to a party other than the account owner/account servicer, for information purposes.
DUPL	Duplicate	Message is for information/confirmation purposes. It is a duplicate of a message previously sent.

USAGE RULES

A message with the Function CANC is used:

- To request the cancellation of a previously sent messages MT540-MT543
- As a cancellation of previously sent messages MT544-MT547, MT535-MT537.

If the message is a cancellation, that is, Function of the Message (field 23G) is CANC, then subsequent Linkages must be present and contain the Sender's reference of the message to be cancelled. In case of cancellation at least mandatory fields of the message must be present.

EXAMPLES

:23G:NEWM

1.8.10. Field 24B Reason

FORMAT

Option G :4!c/[8c]/4!c (Qualifier) (Data Source Scheme) (Reason code)

where

- Qualifier 4!c
- Reason code 4!c

PRESENCE

Mandatory in optional sequence

QUALIFIER

It is recommended to use the following qualifiers in the messages for settlements and corporate actions:

CAND	Cancellation Reason	Specifies the reason why the instruction is cancelled.
CANP	Pending Cancellation Reason	Specifies the reason why a cancellation request sent for the related instruction is pending.
PACK	Acknowledgement Reason	Specifies additional information about the processed instruction.
PEND	Pending Reason	Specifies the reason why the instruction has a pending status.
REJT	Rejection Reason	Specifies the reason why the instruction/request has a rejected status.
NMAT	Unmatched Reason	Specifies the reason why the instruction has an

PENF	Pending/Failing Reason	unmatched status. Specifies the reason why the instruction has a failing settlement status.
PPRC	Pending Processing Reason	Specifies the reason why the instruction has a pending processing status.

DEFINITION

The field specifies the cancellation reason, not matched reason, pending or pending failing reason of the previously received instructions

USAGE RULES

The set of qualifiers and status codes permitted for this field must be bilaterally agreed between the parties:

EXAMPLES

:24B::PEND//CLAC pending reason – insufficient number of securities of the counterparty

:24B::NMAT//CMIS unmatched reason – the instruction is not matched as the counterparty's instruction is missing.

1.8.11. Field 25D Status

FORMAT

Option D :4!c/[8c]/4!c (Qualifier) (Data Source Scheme) (Status code)

where

- Qualifier 4!c
- Status code 4!c

PRESENCE

Mandatory in optional sequence

QUALIFIER

It is recommended to use the following qualifiers in the messages for settlements and corporate actions:

CPRC	Cancellation Processing Status	Provides the status of a cancellation request.
EPRC	Corporate Action Event Processing Status	Provides the status of a corporate action or the status of a payment.
ESTA	Corporate Action Event Stage	Stage in the corporate action event life cycle.
INMH	Inferred Matching Status	Provides the matching status of an instruction as per the account servicer based on an allegation. At this time no matching took place on the market (at the CSD/ICSD).

IPRC	Instruction Processing Status	Provides the status of an instruction.
MTCH	Matching Status	Provides the matching status of the instruction.
SETT	Settlement Status	Provides the status of settlement of an instruction/financial instrument movement.
SPRC	Request for Statement/Status Advice Status	Provides the status of an MT 549 - Request for Statement/Status Advice.
TPRC	Processing Change Command Status	Provides the status of an MT 530 - Processing Change Command.

DEFINITION

The field specifies the instruction processing, matching or settlement status of the instructions previously received by the Sender and related to delivery/receipt of the securities, request status on cancellation of the previously sent instructions, and in the corporate action messages may be given the status of the corporate action or status of the instruction for participation in the corporate action.

USAGE RULES

The set of qualifiers and status codes permitted for this field must be bilaterally agreed by the parties.

EXAMPLES

:25D::SETT//PEND	status of instruction - pending settlement
:25D::MTCH//NMAT	status of instruction – unmatched
:25D::CANC//CAND cancelled	status of the cancellation request – instruction is cancelled

1.8.12. Field 28E Page number/Continuation Indicator

FORMAT

Option E 5n/4!c (Page Tumber) (Continuation IIndicator)

where

- Page Number 5n
- Continuation Indicator 4!c

PRESENCE

Mandatory

DEFINITION

This field specifies the page number and indicates whether the page is the sole or the last one, either in the report, there are additional pages.

QUALIFIER

The following codes are recommended to be present in “Continuation Indicator” subfield:

LAST	Last Page	Last page of a statement with more than one page.
MORE	Intermediate Page	Intermediate page of a statement which contains additional pages.
ONLY	Only Page	Only page of the statement.

EXAMPLES

:28E:2/MORE	second page of the report, will be additional pages
:28E:4/LAST	the fourth and last page of the report
:28E:1/ONLY	the first and only page of the report

1.8.13. Field 35B Identification of the Financial Instrument

FORMAT

Option B	[ISIN1!e12!c]	(Identification of Security)
	[4*35x]	(Description of Security)

where

- ISIN – identification of Security through ISIN1!e12!c
- Description of Security 4*35x

PRESENCE

In the message specification for each field and the set of qualifiers it is specified are they mandatory or optional and this depends on the sequence/subsequence.

DEFINITION

This field identifies the financial instrument and consists of two subfields: subfield for ISO ISIN and subfield for other identifiers of the security and its text description.

USAGE RULES

The following order of securities identification within financial messages is recommended:

When available, ISIN must be used.

When an ISIN identifier is not used it is strongly recommended that the financial instrument should be identified through national state registration number. In this case ISIN subfield is not present, and the identifier is indicated in the first line of the subfield for text information formatted as follows:

- **/RU/ <national state registration number>**

Indication of national state registration number is mandatory, if securities are delivered to or transferred through accounts open in a registrar. In the corporate action messages it is recommended additionally to ISIN to identify state registration number.

If the national state registration number does not allow to identify unambiguously a financial instrument, corporate identifier is recommended to be used with mandatory

indication of financial institution which has assigned this identifier. The conditions of using such corporate identifier should be bilaterally agreed between the parties. Corporate identifier is indicated in the first line of the subfield for text information formatted as follows:

- **/XX/CORP/4!c/<corporate identifier>**, where
4!c – ISO BIC-4 of the financial institution which has assigned this identifier.

EXAMPLES

Financial Instrument Identifier assigned by a financial institution with ISO BIC BANKRUMM is formatted as follows:
:35B:/XX/CORP/BANK/1240987SH

If national state registration number and/or corporate identifier are not available financial instrument details can be provided in narrative form. The information included in the text subfield is bilaterally agreed and may contain the issuer's name, financial instrument type, series, issue number etc.

Financial Instrument Identifier ISIN or Proprietary code is considered as priority while the narrative description of a security may be ignored by the Depository if bilaterally not agreed otherwise.

For User's convenience additional information may be indicated in addition to ISIN, national state registration number or corporate identifier.

1.8.14. Field 36B Quantity

FORMAT

Option B	:4!c//4!c/15d	(Qualifier) (Quantity Type Code) (Quantity)
Option C	:4!c//4!c	(Qualifier) (Quantity Code)
Option E	:4!c//4!c/[N]15d	(Qualifier) (Quantity Type Code) (Sign) (Quantity)

where

- Qualifier 4!c
- Quantity Type Code 4!c
- Sign [N]
- Quantity of Financial Instrument 15d
- Quantity Code 4!c

PRESENCE

In the message specification for each field and the set of qualifiers it is specified are they mandatory or optional and this depends on the sequence/subsequence.

QUALIFIER

It is recommended to use the following qualifiers in the messages for settlements and corporate actions:

ENTL	Entitled Quantity	Quantity of securities based on the terms of the corporate action event and balance of underlying securities entitled to the account owner. (This quantity can be positive or negative).
ESTT	Quantity of Financial Instrument Settled	Quantity of financial instrument effectively settled.
OWND	Quantity of Securities Owned	Quantity of securities belonging to the beneficial owner specified.
PSTA	Posting Quantity	Quantity of securities that have been posted (credit or debit) to safekeeping account.
PSTT	Quantity of Financial Instrument Previously Settled	Quantity of financial instrument previously settled.
QINS	Quantity of Securities Instructed	Quantity of underlying securities to which this instruction applies.
QREC	Quantity to Receive	Quantity of the benefits that the account owner wants to receive, for example, as a result of dividend reinvestment.
RSTT	Quantity of Financial Instrument Remaining to be Settled	Quantity of financial instrument remaining to be settled.

DEFINITION

This field specifies the quantity of securities, which move in the operation of corporate action messages – quantity of accrued securities, quantity of securities which include instruction on the corporate action e.t.c. Quantity type is identified by qualifier.

USAGE RULES

Quantity of securities is expressed in units, Quantity Type Code – UNIT. In certain cases quantity may be expressed as the face amount of the principal of a debt instrument, Quantity Type Code – FAMT (for instructions related to transactions with international securities in international Depository).

If the quantity contains decimals, fractional part must be preceded by decimal comma «,», any other punctuation marks or blanks, are not permitted within the integer part or decimal part (for millions, thousands etc. The number of places following the decimal comma may not exceed the maximum field length (15 characters including separator).

The same restrictions are applied for the subfield «Quantity» and for the subfield «Amount».

The following options are valid:

123,12,3 0,123 123456, 123,0 00123,

The following options are not valid:

123 12.3 .123 ,123 123456 123.456 123,456,

If the quantity of financial instrument has to be indicated in simple fraction (eg, settlements related to corporate action), the following scheme is recommended:

In MT540-547.

The integer part of the amount is indicated in the field :36B: in standard format.

The fractional part of the amount is indicated in the text field :70E::FIAN in subsequence FIA with code word FRAC; numerator and denominator should be separated by slash “/”.

EXAMPLES

:36B::SETT//UNIT/10000, quantity of financial instrument to be credited or debited,

:36B::ESTT//UNIT/5000, quantity of financial instrument, which has been effectively credited or debited.

Quantity of financial instrument - 100 2/3 - is indicated as follows:

:36B::SETT//UNIT/100,

:70E::FIAN//FRAC/2/3

The corporate actions instructions in option C in subfield “Quantity Type Code” may be specified the code identifying that the Instruction applies to the entire eligible balance of underlying securities, which will be on the account at the time of the corporate action:

QALL	All Securities	Instruction applies to the entire eligible balance of underlying securities.
------	----------------	--

EXAMPLES

:36B::ENTL//UNIT/10000, quantity of financial instrument which are entitled to the owner of the account.

:36B::PSTA//UNIT/1600, quantity of financial instrument, which has been booked (debited or credited) on the safekeeping account.

:36B::QINS//UNIT/500, quantity of underlying securities, to which the corporate action instruction on corporate action applies.

:36B::QINS//QALL, Instructions are applicable to the entire eligible balance of the underlying securities.

1.8.15. Field 69a Period

FORMAT

Option A	:4!c//8!n/8!n	(Qualifier) (Date) (Date)
Option B	:4!c//8!n6!n/8!n6!n	(Qualifier) (Date) (Time) (Date) (Time)
Option C	:4!c//8!n/4!c	(Qualifier) (Date) (Date Code)
Option D	:4!c//8!n6!n/4!c	(Qualifier) (Date) (Time) (Date Code)
Option E	:4!c//4!c/8!n	(Qualifier) (Date Code) (Date)
Option F	:4!c//4!c/8!n6!n	(Qualifier) (Date code) (Date) (Time)
Option J	:4!c//4!c	(Qualifier) (Date Code)

where

- Qualifier 4!c
- Period format YYYYMMDD/YYYYMMDD 8!n/8!n
- Period format YYYYMMDDHHMMCC/ YYYYMMDDHHMMCC 8!n6!n/8!n6!n
- Date Code 4!c

PRESENCE

In the message specification for each field and the set of qualifiers it is specified are they mandatory or optional and this depends on the sequence/subsequence.

QUALIFIER

It is recommended to use the following qualifiers in the messages for settlements and corporate actions:

BLOK	Blocking Period	Period during which the security is blocked. (used in Corporate Action messages)
BOCL	Book Closure Period	Period defining the last date on which shareholder registration will be accepted by the issuer and the date on which shareholder registration will resume. (used in Corporate Action messages)
CLCP	Claim Period	Period assigned by the court in a class action. It determines the client's eligible transactions that will be included in the class action and used to determine the resulting entitlement. (used in Corporate Action messages)
CSPD	Compulsory Purchase Period	Period during a take-over where any outstanding equity must be purchased by the take-over company.
INPE	Interest Period	Period during which the interest rate has been applied.
PRIC	Price Calculation Period	Period during which the price of a security is determined.
PWAL	Period of Action	Period during which the specified option, or all options of the event, remains valid, for example, offer period.
REVO	Revocability Period	Period during which the shareholder can revoke, change or withdraw its instruction. (used in Corporate Action messages)
STAT	Statement Period	Period on which the statement is reporting.
SUSP	Suspension of Privilege	Period during which the privilege is not available, for example, this can happen whenever a meeting takes place or whenever a coupon payment is due.
TRDP	Trading Period	Period during which intermediate or outturn securities are tradable in a secondary market.

DEFINITION

This field specifies the accounting period in the statement (STAT).

In corporate actions messages in the field may be specified period of applying of the offer /PWAL/period of applying specified interest rate/INPE/, blocking period /BLOK/ e.t.c.

USAGE RULES

Date must be a valid date expressed by eight digits, and date and time must be expressed by fourteen digits according to one of the appropriate ISO formats: YYYYMMDD or YYYYMMDDHHMMCC, where Y is year, M is month, D is date. Eg, 20060406 means the 6th of April 2006.

In C option subfield "Date code" may specify the following codes: /OBGO/, if the date is identified during the process, /UKWN/, if the date is unknown, /OPEN/, if the date is not specified.

EXAMPLES

:69A::STAT//20110406/20110406 - report is provided for transactions made on the 6th of April 2011

:69B::STAT//20110404000000/20110406235959 - report is provided for transactions made from the 4th to the 6th of April 2011

:69A::PWAL//20111223/20120208 - period of corporate action event

:69A::INPE//20110910/20120310 - period of applying specified interest rate

:69C::BLOK//20120621/ONGO - financial instruments are blocked starting from June 21, 2012

1.8.16. Field 70a Narrative

FORMAT

Option C	:4!c//4*35x	(Qualifier) (Narrative)
Option D	:4!c//86*35x	(Qualifier) (Narrative)
Option E	:4!c//10*35x	(Qualifier) (Narrative)

PRESENCE

Optional

QUALIFIER

It is recommended to use the following qualifiers in the messages for settlements and corporate actions:

DECL	Declaration Details	Provides declaration details narrative relative to the party.
FIAN	Financial Instrument Attribute Narrative	Provides additional information about the financial instrument in narrative form.

PACO	Party Narrative	Provides additional information regarding the party, for example, the contact unit or person responsible for the transaction identified in the message.
REAS	Reason Narrative	Provides additional reason information.
REGI	Registration Details	Provides information required for the registration.
SPRO	Settlement Instruction Processing Narrative	Provides additional settlement processing information which can not be included within the structured fields of the message.
TRDE	Transaction Details Narrative	Provides additional details on the transaction which can not be included within the structured fields of the message.

DEFINITION

The field contains qualifier and narrative subfield. The field may contain additional information related to securities, trade details, party, transaction basis and other data, that is not associated with appropriate predefined fields in a message.

USAGE RULES

If it is necessary to specify text information in Corporate Actions messages, the possibility of a foreign language and/or transliteration should be determined by mutual agreement of the parties.

In order to indicate the contact person, telephone number, e-mail address in all messages on corporate actions (MT564, MT565, MT566) it is recommended to use field 70E with qualifier PACO.

EXAMPLES

```
:70E::PACO//CUSTODY DEPT
PETROV IVAN
TEL 8 499 245 75 68
EMAIL PETROV (AT) DEPO.RU
```

If in Corporate Action messages MT564 the field 70E contain narrative description of the information which is included in the message's structured fields and automated processing of this information is not required it is recommended to use qualifier /TXNR/.

In order to ensure straight through processing (STP) this field is recommended to be structured. For the moment there are the following codes:

- Contract types,
- Registration details, if the Place of Settlement is the Registrar,
- Account type of the registered person of the Delivering/Receiving Agent of the securities, if the Place of Settlement is the Registrar.

This information is recommended to be specified in narrative fields 70 in SETPRTY sequence with the qualifier DEAG/REAG with single slash "/" as separator between the code word and the data after it.

Details of documents – reason of transactions.

FORMAT

:70E::DECL//TYPE/document's code[/NAME/document's name]/NUMB/ document's number/DATE/ document's date

If the document's name is different from the codes listed below, it should be explained in the subfield after the code /NAME/. In this case the code subfield should contain the code /OTHR/.

The document's date must be entered in the form YYYYMMDD.

In the absence of the document's number the code /DATE/ and the document's date should be entered immediately after the code word /NUMB/. The following indicators are NOT recommended to be used: "w/n", "without number".

CODES

The following codes are recommended to be used for definition of the document's type:

- BYSA contract of purchase and sale
- EXGA contract of exchange
- NOMA agreement of nominal holding
- INDA intra-depository agreement
- DEPA depository agreement
- NCBO client's instruction (used for instructions of securities' delivery/receipt when no transfer of property right occurs)
- PLGA pledge contract
- DSTA contract of deposit/storage (deposit agreement)
- TRSA trustee management contract
- ORDA agency contract
- GIFA gift agreement
- COLA contract of lending (credit agreement)
- COMC contract of commission
- AGTC agent contract
- OTHR narrative description of a different basis of transaction

One and the same field :70E: may contain several bases of transaction.

EXAMPLES

:70E::DECL//TYPE/OTHR/NAME/'REQENIE ARBITRAJNOG
O SUDA'/NUMB/25/DATE/20040914/TYPE/
BYSA/NUMB//123-MD/DATE/20041014

Registration details.

FORMAT

:70D::REGI//TYPE/code[/NAME/name]/NUMB/[document's number]/DATE/
document's date/REGA/name of the authority or institution that issued the document

In registration details in compliance with regulating documents the following information should be specified: registration information (for juridical person) and information about the document confirming the person's identity (for individual person).

If the document's name is different from the codes listed below, it should be explained in the subfield after the code /NAME/. In this case the code subfield should contain the code /OTHR/.

In the absence of the document's number the code /DATE/ and the document's date should be entered immediately after the code word /NUMB/. The following indicators are NOT recommended to be used: "w/n", "without number". If the document's series is present it should be separated from the number by double slash.

One and the same field :70D: may contain data related to several documents.

CODES

The following details can be specified:

- NUMB document's number
- DATE date of issuance, YYYYMMDD
- REGA institution's name
- TYPE 4!c document's type, where
- NAME narrative description of the document (for OTHR type)

The following codes are recommended to be used for definition of the document's type:

For individual persons:

- CCPT passport
- BIRT birth-certificate
- FCCP foreign passport
- OTHR other documents issued by the Ministry of Internal Affairs

For juridical persons:

- BKLC license of the Bank of Russia
- LICS licenses
- STIC registration certificate
- OGRN certificate of registration in the the Uniform State Register of Legal Entities of Russian Federation
- OTHR other

One and the same field :70D: may contain several bases of transaction.

Passport details of an individual should be provided in compliance with the following recommendations:

- only subfields after the codes /DATE/ and /REGA/ should be used;
- if several registration documents of an individual are present, passport details should be indicated first in the field :70D::REGI;
- for this document the subfield /NAME/ is not permitted to be present;
- passport series and number should be specified in the field :95S::ALTE (section 0).

EXAMPLE 1

Indication of a registration certificate of a legal entity (before the 1st of July 2002) and a certificate of registration in the the Uniform State Register of Legal Entities of Russian Federation:

:70D::REGI//TYPE/STIC/NUMB/123.456/DATE/2001101
1/REGA/'MRP'/TYPE/OGRN/NUMB/1025501
341252/DATE/20030511/REGA/'MEJRAiON
NAa INSPEKCIa MNS

EXAMPLE 2

Indication of details of a foreign passport of an individual person:

:70D::REGI//TYPE/FCCP/NUMB/99//1234567/
DATE/20040127/REGA/'UVD 653

EXAMPLE 3

Indication of details of a passport of an individual:

:70D::REGI//TYPE/CCPT/NUMB//DATE/20030612/REGA/
'OVD ZuZINO G.MOSKVY

The document's series and number are specified in the field :95S::ALTE (Example 1 section 0).

Account type for transactions where the place of settlements is the Registrar.

FORMAT

:70C::PACO//OWNT/4!c, where
4!c – account type code.

CODES

- OWNE owner account
- TRUS trustee manager account
- NOMI nominee account
- DEPO deposit account
- ISSR issuer (issuer account)
- OTHR other accounts set by the federal law – with possibility to specify the name of the account
- PLED pledgeholder account
- NDCD nominee account of the central depository

The field is recommended to use for the transactions which are processed through registrar.

EXAMPLE

:70C::PACO//OWNT/OWNE
:70C::PACO//OWNT/NOMI

1.8.17. Field 90a Price

FORMAT

Option A	:4!c//4!c/15d	(Qualifier) (Percentage Type Code) (Price)
Option B	:4!c//4!c/3!a15d	(Qualifier) (Amount Type Code) (Currency code) (Price)
Option E	:4!c//4!c	(Qualifier) (Price Code)
Option F	:4!c//4!c/3!a15d/4!c/15d	(Qualifier) (Amount Type Code) (Currency code) (Price) (Quantity Type Code) (Quantity)
Option J	:4!c//4!c/3!a15d/3a!15d	(Qualifier) (Amount Type Code) (Currency Code) (Amount) (Currency Code) (Amount)
Option K	:4!c//15d	(Qualifier) (Index Points)

where

- Qualifier 4!c
- Percentage Type Code 4!c
- Price 15d
- Amount Type Code 4!c
- ISO – Currency Code 3!a
- Price Code 4!c
- Amount 15d
- Quantity Type Code 4!c
- Quantity 15d
- Index Points 15d

PRESENCE

Optional

QUALIFIER

It is recommended to use the following qualifiers in the messages for settlements and corporate actions:

DEAL	Deal Price	Price of the traded financial instrument.
INDC	Indicative Price	Estimated price, for example, for valuation purposes.
MRKT	Market Price	Last reported/known price of a financial instrument in a market.

CODES

In option A subfield “Percentage Type Code” must contain one of the following codes:

DISC	Discount	Price expressed as the number of percentage points below par, for example, a discount price of 2.0% equals a price of 98 when par is 100.
PRCT	Percentage	Price expressed as a percentage of par.
PREM	Premium	Price expressed as the number of percentage points above par, for example, a premium price of 2.0% equals a price of 102 when par is 100.
YIEL	Yield	Price expressed as a yield.

In option B subfield “Amount Type Code” must contain one of the following codes:

ACTU	Actual Amount	Price expressed as an amount of currency per unit or per share.
DISC	Discount	Price expressed as a discount amount.
PLOT	Lot	Price expressed as an amount of money per lot.
PREM	Premium	Price expressed as a premium.

In option F subfield “Quantity Type Code” must contain one of the following codes:

AMOR	Amortised Value	Quantity expressed as an amount representing the current amortised face amount of a bond, for example, a periodic reduction/increase of a bond's principal amount.
FAMT	Face Amount	Quantity expressed as an amount representing the face amount, that is, the principal, of a debt instrument.
UNIT	Unit Number	Quantity expressed as a number, for example, a number of shares.

In option F subfield “Price code” must contain the following code:

UKWN	Unknown Price	Price is unknown by the sender or has not been established.
------	---------------	---

DEFINITION

The field may contain information on market value of the financial instrument, price of execution /EXER/, price per product /OFFR/ etc. Used in the messages on the corporate actions.

USAGE RULES

Currency code should be current ISO code (validated by the network).

EXAMPLES

:90A::OFFR//PRCT/77,441745578	bid price as a percentage of par value
:90B::OFFR//ACTU/RUB0,0284	actual price of the offer
:90B::PRPP//ACTU/RUB0,5	price of reinvestment
:90E::OFFR//UKWN	bid price is unknown
:90F::OFFR//PLOT/USD100,/FAMT/1000	bid price per lot

1.8.18. Field 92a Rate

FORMAT

Option A	:4!c//[N]15d	(Qualifier) (Sign) (Rate)
Option B	:4!c//3!a/3!a/15d	(Qualifier) (First Currency Code) (Second Currency Code) (Rate)
Option C	:4!c//[8c]/24x	(Qualifier) (Data Source Scheme) (Rate Name)
Option D	:4!c//15d /15d	(Qualifier) (Quantity) (Quantity)
Option E	:4!c//4!c/[N]15d[4!c]	(Qualifier) (Rate type code) (Sign) (Rate) (Rate status)
Option F	:4!c//3!a15d	(Qualifier) (Currency Code) (Amount)
Option J	:4!c//[8c]/4!c/3!a15d[4!c]	(Qualifier) (Data Source Scheme) (Rate Type Code) (Currency Code) (Amount) (Rate Status) (Qualifier) (Rate Type Code)
Option K	:4!c//4!c	(Qualifier) (Rate Type Code)
Option L	:4!c//3!a15d/3!a15d	(Qualifier) (First Currency Code) (Amount) (Second Currency Code) (Amount)
Option M	:4!c//3!a15d/15d	(Qualifier) (Currency Code) (Amount) (Quantity)
Option N	:4!c//15d/3!a15d	(Qualifier) (Quantity) (Currency Code) (Amount)

where

- Qualifier 4!c
- Sign [N]
- Rate 15d
- ISO – Currency Code 3!a
- Rate Name 24x
- Quantity 15d
- Amount 15d
- Rate Type Code 4!c
- Rate Status 4!c

PRESENCE

Optional

QUALIFIER

It is recommended to use the following qualifiers in the messages for settlements and corporate actions:

ADEX	Additional for Existing Securities	Quantity of additional securities for a given quantity of underlying securities where underlying securities are not exchanged or debited, for example, 1 for 1: 1 new equity credited for every 1 underlying equity = 2 resulting equities.
ADSR	Additional for Subscribed Resultant Securities	Quantity of additional intermediate securities/new equities awarded for a given quantity of securities derived from subscription.
EXCH	Exchange Rate	Exchange rate between the amount and the resulting amount.
NEWO	New to Old	Quantity of new securities for a given quantity of underlying securities, where the underlying securities will be exchanged or debited, for example, 2 for 1: 2 new equities credited for every 1 underlying equity debited = 2 resulting equities.
INTR	Interest Rate	Annual rate of a financial instrument.
NWFC	Next Factor	Rate expressed as a decimal between 0 and 1 that will be applicable as of the next factor date and defines the outstanding principal of the financial instrument (for factored securities).
NXRT	Next Interest Rate	Interest rate applicable to the next interest payment period in relation to variable rate instruments.
PRFC	Previous Factor	Rate expressed as a decimal between 0 and 1 that was applicable before the current factor and defines the outstanding principal of the financial instrument (for factored securities).
PRIC	Pricing Rate	Interest rate to be paid on the transaction amount, as agreed between the counterparties.
REPO	Repurchase Rate	Repurchase rate used to calculate the repurchase amount.
RSPR	Spread Rate	Margin over or under an index that determines the repurchase rate.

In option J if qualifier is "INTP" subfield "Rate Type Code" must contain one of the following codes:

SCHD	Scheduled	Rate of the scheduled payment.
USCD	Unscheduled	Rate of the unscheduled payment.

In option J if qualifier is "NETT" subfield "Rate Type Code" must contain one of the following codes:

INCO	Income Portion	Rate relating to the underlying security for which income is distributed.
------	----------------	---

INTR	Interest	Rate relating to the underlying security for which interest is paid.
SOIC	Sundry/Other Income	Rate relating to the underlying security for which other income is paid.
TXBL	Taxable Portion	Rate relating to the underlying security for which tax is charged.
TXDF	Tax Deferred	Rate relating to the underlying security for which tax is deferred.
TXFR	Tax Free	Rate relating to the underlying security which is not taxable.
UNFR	Unfranked	Unfranked

In option K if qualifier is other than “GRSS” or “INTP” and “Data Source Scheme” is not present, subfield “Rate Type Code” must contain the following code:

UKWN	Unknown Rate	Rate is unknown by the sender or has not been established.
------	--------------	--

The rate is specified on the basis of reference or basic rate which are identified in option C in subfield “Rate Name” (for example, EONIA, EURIBOR, LIBOR, FEFUND, EURREPO) etc.

DEFINITION

The field may contain information on annual interest rate, rate applicable to the corporate action, rate of exchanging new securities to the existing, exchange rate etc.

USAGE RULES

Currency code should be valid ISO code (validated by the network).

If the value is negative the subfield “Sign” should be used.

Subfield “Rate Status” is “ACTU” by default.

Unless otherwise indicated in the definition, the rate should be expressed as a percentage but not decimals.

EXAMPLES

:92A::INTR//11	annual interest rate
:92A::NWFC//0,1234567	next value of the factor which is used to calculate the unpaid principal amount of the financial instrument
:92B::EXCH//RUB/USD/0,03216406244	exchange rate
:92D::NEWO//3,/1, underlying equity debited	3 new equities credited for every 1
:92F::INTP//USD55,	interest rate for the payment
:92J::GRSS//TXBL/EUR0,7	taxable underlying securities rate
:92K::RATE//UKWN	unknown rate
:92K::RATE//OPEN	unknown rate
:92L::NEWO//RUB100000,/RUB100000,	assimilation rate (CAEV//PARI)

1.8.19. Field 93a Balance

FORMAT

Option A	:4!c/[8c]/4!c	(Qualifier) (Data Source Scheme) (Balance Type Code)
Option B	:4!c//[8c]/4!c/[N]15d	(Qualifier) (Data Source Scheme) (Quantity type code) (Aign) (Balance)
Option C	:4!c/4!c/4!c/[N]15d	(Qualifier) (Quantity type code) (Balance type code) (Sign) (Balance)

where

- Qualifier 4!c
- Quantity type code 4!c
- Balance type code 4!c
- Negative Balance Sign [N]
- Balance 15d

PRESENCE

Mandatory in optional sequence

QUALIFIER

It is recommended to use the following qualifiers in the messages for settlements and corporate actions:

BLOK	Blocked	Balance of financial instruments that are blocked.
ELIG	Total Eligible for Corporate Action Balance	Total balance of securities eligible for this corporate action event. The entitlement calculation is based on this balance.
PEND	Pending Delivery	Balance of financial instruments that are pending delivery.
PENR	Pending Receipt	Balance of financial instruments that are pending receipt.
REGO	Out for Registration	Balance of financial instruments currently being processed by the institution responsible for registering the new beneficial owner (or nominee).
SETT	Settlement Position Balance	Balance of securities representing only settled transactions; pending transactions not included.
SPOS	Street Position	Balance of financial instruments that remain registered in the name of the prior beneficial owner.
TRAD	Trade Date Position Balance	Balance of securities based on trade date, for example, includes all pending transactions in addition to the balance of settled transactions.

TRAN	In Transshipment	Balance of physical securities that are in the process of being transferred from one depository/agent to another.
UNAF	Unaffected Balance	Balance that has not been affected by the process run through the corporate event.

DEFINITION

The field specifies the overall securities balance for the safekeeping account, the securities balance for sub-accounts and the availability of operations.

USAGE RULES

Option B is used to specify the aggregate balance, i.e., overall quantity of securities for the sub-account. In this case the qualifier AGGR should be indicated in the first subfield.

Option C is used to segregate the sub-account's balance by status and availability for operations. The usage of permitted qualifiers should be bilaterally agreed between the parties.

Quantity Type Code for the field must be UNIT.

Balance Type Code AVAI is used if the financial instrument is available for any purpose, and NAVL is used, if the securities are unavailable for settlement.

The integer part of the Balance subfield must contain at least one digit. A decimal comma “,” is mandatory and is included in the maximum length.

EXAMPLES

:93B::AGGR//UNIT/5000, securities aggregate balance in the indicated account

:93C::PEND//UNIT/NAVL/N1000, balance of financial instruments with pending delivery status

:93C::PENR//UNIT/NAVL/250, balance of financial instruments with pending receipt status

:93C::REGO//UNIT/NAVL/250, balance of securities that are out for re-registration

:93C::BLOK//UNIT/NAVL/1500, Balance of financial instruments that are blocked or unavailable for delivery

:93C::TAVI//UNIT/AVAI/2000, total balance of all available securities

:93B::ELIG//UNIT/100000,00 balance of securities which fall within the scope of corporate action

:93B::CONB//UNIT/100000,00 confirmed securities balance

1.8.20. Field 94a Place

FORMAT

Option B	:4!c/[8c]/4!c/[30x]	(Qualifier) (Data Source Scheme) (Place code) (Narrative)
Option C	:4!c//2!a	(Qualifier) (Country code)
Option D	:4!c//[2!a]/35x	(Qualifier) (Country code) (Place)
Option F	:4!c//4!c /4!a2!a2!c[3!c]	(Qualifier) (Place code) (Identifier Code)

Option G	:4!c//2*35x	(Qualifier) (Address)
Option H	:4!c//4!a2!a2!c[3!c]	(Qualifier) (Identifier Code)

where

- Qualifier 4!c
- Data Source Scheme [8c]
- ISO-Country Code 2!a
- Text (address) 2*35x
- Place Type Code 4!c
- Text (name) 35x
- Address 2*35x

PRESENCE

Optional

QUALIFIER

It is recommended to use the following qualifiers in the messages for settlements and corporate actions:

CLEA	Place of Clearing	Place at which the trade is cleared (Central Counterparty).
SAFE	Place of Safekeeping	Location where the financial instruments are/will be safekept.
TRAD	Place of Trade	Place at which the order was traded, directly by the instructing party or not.

In option G in Corporate Action messages this field may contain place of meeting or new place of listing of the company:

MEET	Meeting Place	Place of the company's meeting for the scheduled meeting date.
MET2	Meeting Place 2	Place of the company's meeting for the scheduled second meeting date.
MET3	Meeting Place 3	Place of the company's meeting for the scheduled third meeting date.
NPLI	New Place of Incorporation	New company's place of incorporation.

DEFINITION

The field specifies safekeeping data, listing, place of living, place of meeting e.t.c.

<u>Place of safekeeping-</u>	Location where the financial instruments or global certificate are/will be safekept. Place of safekeeping may be depository or registrar. Used in Corporate Action messages.
<u>Place of listing-</u>	Determines the market where financial instrument is listed. Used in the messages for corporate actions.
<u>Place of domicile-</u>	Place of domicile (qualifier /DOMI/) or non-domicile (qualifier /NDOM/) the owner of the securities. Used in

Corporate Action messages.

USAGE RULES

Country Code must be a valid ISO code (network validated).

Place of listing is to be identified by corresponding Market Identifier Code, MIC).

In option F Place Code can be specified:

CUST	Local Custodian
NCSD	National Central Securities Depository
ICSD	International Central Securities Depository
SHHE	Shares held Elsewhere e.t.c.

EXAMPLES

:94F::SAFE//CUST/CITIGB2LMAG

:94F::SAFE//NCSD/DAKVDEFFXXX

To indicate that the securities are kept in registrar option B is to be used with REGISTRAR code:

:94B::SAFE//SHHE/REGISTRAR

:94C::DOMI//RU country of domicile of the securities owner

:94C::NDOM//DE owner is not domiciled in the states country

:94B::PLIS//EXCH/XMOS place of listing

:94G::MEET//5 Bank of America Center Auditorium
123 North College place of meeting

1.8.21. Field 95a Party

FORMAT

Option C	:4!c//2!a	(Qualifier) (Country Code)
Option P	:4!c//4!a2!a2!c[3!c]	(Qualifier) (Identifier Code)
Option Q	:4!c//4*35x	(Qualifier) (Name and Address)
Option R	:4!c//8!c /34x	(Qualifier) (Data Source Scheme) (Proprietary Code)
Option S	:4!c//[8c]/4c/2!a/30x	(Qualifier) (Data Source Scheme) (Type of ID) (Country code) (Alternate ID)

where

- Qualifier 4!c
- BIC/BEI 4!a2!a2!c[3!c]
- Name of the party 4*35x
- Data Source Scheme 8c
- Proprietary Code 34x

- Type of identifier 4!c
- Country Code ISO 2!a
- Alternate ID 30x

Party identification options have the following meaning:

- Option P - ISO Bank Identifier Code (BIC) published in BIC Directory
- Option Q – Name and Address
- Option R – Proprietary Code of financial institution
- Option S – Alternate ID

In all cases the usage of any option is to be bilaterally agreed between the parties.

PRESENCE

Mandatory

QUALIFIER

It is recommended to use the following qualifiers in the messages for settlements and corporate actions:

ACOW	Account Owner	Party that owns the account.
------	---------------	------------------------------

Settlement parties involved in transactions with securities:

BUYR	Buyer	Party that receives the financial instrument.
DEAG	Delivering Agent	Delivering party that interacts with the place of settlement.
DECU	Deliverer's Custodian	Party that interacts with the delivering agent unless intermediaries exist.
DEI1	Deliverer's Intermediary 1	Party that interacts with the delivering agent.
DEI2	Deliverer's Intermediary 2	Party that interacts with the deliverer's intermediary 1.
PSET	Place of Settlement	Place of Settlement
REAG	Receiving Agent	Receiving party that interacts with the place of settlement.
RECU	Receiver's Custodian	Party that interacts with the receiving agent unless intermediaries exist.
REI1	Receiver's Intermediary 1	Party that interacts with the receiving agent.
REI2	Receiver's Intermediary 2	Party that interacts with the receiver's intermediary 1.
SELL	Seller	Party that delivers the financial instrument.

Cash parties:

ACCW	Account With Institution	Financial institution that services the cash account of the beneficiary customer, if other than the Receiver.
------	--------------------------	---

ALTE	Alternate ID	Alternate identification for a party.
BENM	Beneficiary of Money	Ultimate party to be credited with the money.
DEBT	Debtor	Paying agent ordering customer or debtor.
PAYE	Paying Institution	Party from whose account the payment needs to be done, if different from the Sender's account.

Also in Corporate Action messages:

ISAG	Issuer Agent	Party appointed to administer the event on behalf of the issuer company/offeror. The party may be contacted for more information about the event.
PAYA	Paying Agent	Agent (principal or fiscal paying agent) appointed to execute the payment for the corporate action event on behalf of the issuer company/offeror.
PSAG	Physical Securities Agent	A trust company, bank or similar financial institution assigned by an issuer to accept presentations of instruments, usually bonds, for transfer and or exchange.
REGR	Registrar	Party or Agent responsible for securities register maintenance and services.
RESA	Reselling Agent	A broker-dealer responsible for reselling to new investors securities (usually bonds) that have been tendered for purchase by their owner.
SOLA	Solicitation Agent	A trust company, bank or similar financial institution assigned by an issuer to maintain records of investors and account balances and transactions for the consent of a material change.

DEFINITION

The field contains identifier or text description of party involved in transaction. Qualifiers identifying the parties are used to specify their position in settlement chain and their relations with other parties involved in delivery and/or settlements.

Option P: ISO Bank Identifier Code (BIC)

FORMAT

:95P::4!c//4!a2!a2!c[3!c], where

- Qualifier – 4!c
- BIC/BEI 4!a2!a2!c[3!c]

USAGE RULES

Option **P** is used to identify financial institutions with assigned SWIFT code.

NB! SWIFT validates BIC

The subfield “BIC” contains ISO Bank Identifier Code (BIC).

It is recommended to identify Russian financial institutions with Option P in case if both the Sender and the Receiver of the message support the Directory of correspondence between ISO BICs and the names of settlement participants in the Russian Federation and should be bilaterally agreed between the parties.

Option P is recommended to be used:

- To identify the counterparty when financial instruments are to be transferred between safekeeping accounts opened at the same financial institution (operation type – “book transfer”);
- To identify the Place of Settlement (qualifier PSET);
- To identify parties when settlement is effected through international Depositories.

EXAMPLE

:95P::PSET//DEPORUMM – Place of Settlement, i.e., financial institution where securities are transferred between accounts.

Option Q: Name and address of the financial institution

FORMAT

:95Q::4!c//4*35x, where

- Qualifier 4!c
- Name and Address 4*35x

USAGE

Option Q can be used if it's not possible to use Option P or if there's a bilateral agreement between the parties permitting its use.

In case of internal transfers it is recommended to specify in this field the identifier assigned by settlement Depository, in case of inter depository transfers – the identifier assigned by correspondent Depository. In case if the Place of Settlement for the transaction is the Registrar, code REGISTRAR can be indicated instead of the name and address of the concrete Registrar.

EXAMPLE

:95Q::REAG//ZAO 'RAScoTNO-DEPOZITARNAa KOMPANIa'

:95Q::PSET//REGISTRAR

Option R – Proprietary Code of financial institution

FORMAT

:95R::4!c/8c/34x, where

- Qualifier 4!c
- Data Source Scheme 8c
- Proprietary Code 34x

The subfield “Proprietary Code” specifies the local national code or market segment code to identify the party.

The subfield “Data Source Scheme” specifies the code permitted to be used on S.W.I.F.T. network.

This option may be used to identify the institution with a proprietary code, assigned by the market operator or depository. Data Source Scheme should be registered in SWIFT as applicable system for the given field. Currently Russian CSD code is registered as Data Source Scheme – NSDR.

Option S – Alternate ID

FORMAT

:95S::4!c/[8c]/4c/2!a/30x

- Qualifier 4!c
- Data Source Scheme 8c
- Type of ID 4c
- Country Code 2!a
- Alternate ID 30x

The subfield “Alternate ID” contains the alternate identification of the party specified in the same sequence.

The subfield “Data Source Scheme” specifies the code permitted to be used on S.W.I.F.T. network.

The subfield “Type of ID” specifies the alternate ID’s type which can be used to identify the party, e.g., non-resident’s registration number, passport number, tax-payer’s identification number, corporate identifier.

The subfield “Country Code” specifies the country where the applied party’s alternate ID is valid. This must be a valid ISO country code.

The subfield “Alternate ID” specifies the party’s alternate identification.

In the current standards release the field with this option is recommended to be used to specify passport number:

:95S::/ALTE//CCPT/RU/passport number

The passport series (if present) should be separated from the passport number by double slash.

EXAMPLE1:

:95S::ALTE//CCPT/RU/4505//123456

Field with this option can also specify the tax-payer’s identification number:

:95S::ALTE//TXID/RU/tax-payer’s identification number

EXAMPLE2:

:95S::ALTE//TXID/RU/1234567890

1.8.22. Field 97a Account

FORMAT

This field specifies the type and the account number of the party involved in the transaction.

Option A	:4!c//35x	(Qualifier) (Account Number)
Option B	: 4!c/[8c]/4!c/35x	(Qualifier) (Data Source Scheme) (Account Type Code) (Account Number)
Option C	: 4!c//4!c	(Qualifier) (Account Type Code)

Option E :4!c/34x

(Qualifier) (International Bank Account Number -IBAN)

where

- Qualifier 4!c
- Data Source Scheme 8c
- Account Type Code 4!c
- Account Number 35x

PRESENCE

Optional

QUALIFIER

It is recommended to use the following qualifiers in settlements and Corporate Action messages:

CASH	Cash Account	Account in which cash is maintained.
SAFE	Safekeeping Account	Account where financial instruments are maintained.
REGI	Registrar Account	Account at the registrar where financial instruments are registered.

It is recommended to use the following qualifiers in the messages for corporate actions in option C subfield "Account Type Code":

GENR	General	Announcement applies to all safekeeping accounts that own underlying financial instrument. (Used for general or preliminary announcements).
------	---------	---

DEFINITION

The account provided is the account of the party specified in this sequence.

USAGE RULES

Option B is not used in the current standards version.

The field may contain qualifier SAFE for safekeeping account and CASH for cash account.

If a financial instrument is transferred between accounts within a financial institution or through a correspondent institution the presence of account number is mandatory.

For cash account following procedure is recommended if the field contains the qualifier CASH:

- field specified in the sequence FIAC, if the safekeeping account and cash account are serviced by the same financial institution
- field specified in subsequence CSHPARTY, if the safekeeping account and cash account are serviced by different financial institutions.

If qualifier PSET is present in subsequence SETPARTY then field 97a::SAFE is not allowed in the same subsequence.

In corporate action messages in option C GENR code can be used - to show that announcement applies to all safekeeping accounts that own underlying financial instrument.

EXAMPLES

:97A::SAFE//MS12345678 safekeeping account

:97A::CASH//500345321 cash account.

:97C::SAFE//GENR all accounts with securities balances

For internal transfers between sections (sub-accounts) of safekeeping accounts it is recommended to specify the sections as follows:

Safekeeping account should be specified in Field :97a:.

If the section (sub-account) code is present, it is recommended to specify it in the same field after the account number with the code word /KRZD/. Section code may be specified after two consecutive slashes without code word KRZD.

There's no restriction on the number of characters in the account number and the section (sub-account) code, but the overall quantity of [Sign]

s in the field including the code /KRZD/ must not exceed 35.

EXAMPLES

:97A::SAFE//MS9801147521/KRZD/31MC0009900000F00

:97A::SAFE//MS9801147521//31MC0009900000F00

1.8.23. Field 98a Date/Time

FORMAT

Option A	:4!c//8!n	(Qualifier) (Date)
Option B	:4!c/[8c]/4!c	(Qualifier) (Data Source Scheme) (Date Code)
Option C	:4!c//8!n6!n	(Qualifier) (Date) (Time)
Option E	:4!c//8!n6!n[,3n]/[N]2!n [2!n]	(Qualifier) (Date) (Time) (Decimals) (UTC Indicator)
Option F	:4!c/[8c]/4!c6!n	(Qualifier) (Data Source Scheme) (Date Code) (Time)

where

- Qualifier 4!c
- Date format YYYYMMDD 8!n
- Date format MMDD 4!n
- Date and Time format YYYYMMDDHHMMCC 8!n6!n
- Date Code 4!n
- Decimals [,3n]
- UTC Indicator [/[N]2!n[2!n]]

PRESENCE

Mandatory/optional depending on the type of the date

QUALIFIER

In the messages for settlements and corporate actions usage of the following qualifiers is recommended:

ESET	Effective Settlement Date/ Time	Date/time at which a transaction effectively settled.
SETT	Settlement Date/ Time	Date/time at which the financial instruments are to be delivered or received.
TRAD	Trade Date/Time	Date/time at which the deal (rights) was agreed
PREP	Preparation Date	Date on which message was prepared.

In corporate actions messages the following qualifiers can be specified:

ANOU	Announcement Date/Time	Date/time at which the issuer announced that a corporate action event will occur.
EFFD	Effective Date/Time	Date/time at which an event is officially effective from the issuer's perspective.
EXPI	Expiry Date	Date/time at which an order expires or on which a privilege or offer terminates.
EXRQ	Execution Requested Date/ Time	Date/time at which the instructing party requests the instruction to be executed.
MEET	Meeting Date/Time	Date/time at which the bondholders' or shareholders' meeting will take place.
MKDT	Market Deadline Date/Time	Issuer or issuer's agent deadline to respond, with an election instruction, to an outstanding offer or privilege.
PAYD	Payment Date/ Time	Date/time at which the movement is due to take place (cash and/or securities).
POST	Posting Date/Time	Date of the posting (credit or debit) to the account.
RDDT	Response Deadline Date/Time	Date/time at which the account servicer has set as the deadline to respond, with instructions, to an outstanding event. This time is dependent on the reference time zone of the account servicer as specified in an SLA.
RDTE	Record Date/Time	Date/time at which positions are struck at the end of the day to note which parties will receive the relevant amount of entitlement, due to be distributed on payment date.

In Corporate Action messages on Russian securities ex-dividend date is not applicable (for shares it is equal to the record date) as well as the qualifier:

XDTE	Ex-Dividend or Distribution Date/Time	Date/time as from which trading (including exchange and OTC trading) occurs on the underlying security without the benefit.
------	---------------------------------------	---

DEFINITION

This field may specify the date on which message was prepared, the date on which the transaction was done, the date on which the trade was agreed, the date on which the message was processed in the Settlement institution or Depository etc.

- Date/time at which an order expires or on which a privilege or offer terminates /EXPI/,
- Date/time at which an event is officially effective from the issuer's perspective /EFFD/ etc.

In option B if “Data Source Scheme” subfield is not present, the subfield “Date Code” must contain one of the following codes:

ONGO	Ongoing Basis	Date is determined by "on going basis" process, for example "au fil de l'eau".
UKWN	Unknown Date	Date is unknown by the sender or has not been established.

USAGE RULES

Date must be a valid date expressed by four or eight digits, and date and time must be expressed by fourteen digits according to one of the appropriate ISO formats: MMDD, YYYYMMDD or YYYYMMDDHHMMCC, where Y is year, M is month, D is date. Eg, 20040305 means the 5th of March 2004.

The information type is specified by the Qualifier.

Option A should be used to specify the settlement date and the trade date and option C – to specify the date on which the instruction was prepared/processed.

EXAMPLES

:98A::SETT//20040310 expected settlement date indicated in the instruction

:98A::ESET//20040310 date/time at which a transaction effectively settled in the institution indicated as the Place of Settlement

:98A::TRAD//20040305 date at which the deal was agreed

:98C::PROC//20040305124500 date and time on which the instruction was processed

:98E::PREP//20120206075642,600 date and time on which the message was prepared

:98A::RDTE//20120309 holder of record date (in Corporate Action messages)

:98A::MATU//20180310 maturity date (in Corporate Action messages)

:98A::EXPI//20120301 date/time at which an order expires (in Corporate Action messages)

:98A::FRNR//20120309 Date on which the interest rate of an interest bearing financial instrument will be/was calculated (in Corporate Action messages)

:98C::RDDT//20120301160000 date/time at which the account servicer has set as the deadline to respond (in Corporate Action messages)

:98A::POST//20120214 date of the posting (credit or debit) to the account (in Corporate Action messages)

:98A::PAYD//UKWN date/time at which the movement is due to take place (cash and/or securities).is unknown (in Corporate Action messages)

1.8.24. Field 99a Number

FORMAT

Option A :4!c//[N]3!n (Qualifier) (Sign) (Number)

where

- Qualifier 4!c
- Sign [N]
- Number [3!a]

PRESENCE

Optional

DEFINITION

This field may specify number of days used for calculating the accrued interest amount. (qualifier DAAC). Used in Corporate Action messages.

USAGE RULES

With negative value subfield “Sign” should be used.

EXAMPLES

:99A::DAAC//031

2. FORMATS OF SETTLEMENT INSTRUCTIONS

2.1 MT540 RECEIVE FREE

This message is sent by an account owner to an account servicer (account servicing institution). This message is used to:

- instruct the receipt of financial instruments free of payment, physically or by book-entry, from a specified party (the function of the message is NEWM)
- request the cancellation of a receive free of payment instruction previously sent by the account owner (the function of the message is CANC)
- pre-advise the account servicer of a forthcoming receive free of payment instruction (the function of the message is PREA).

2.1.1. Format Specifications

Status	Tag	Detaild Field Name	Content/Options	Qualifier	№ RUS	№ SWIFT User Handbook
Mandatory Sequence A General Information						
M	:16R:	Start of Block	GENL			1
M	:20C:	Sender's Message Reference	:4!c//16x	SEME	1.8.6	2
M	:23G:	Function of the Message	4!c[/4!c]		1.8.9	3
O	:98a:	Preparation Date/Time	A,C or E	PREP	1.8.23	4
Optional Repetitive Subsequence A1 Linkages						
M	:16R:	Start of Block	LINK			6
M	:20C:	Linked Message Reference	:4!c//16x	:4!c	1.8.7	9
M	16S:	End of Block	LINK			11
End of Subsequence A1 Linkages						
M	:16S:	End of Block	GENL			12
End of Sequence A General Information						
Mandatory Sequence B Trade Details						
M	:16R:	Start of Block	TRADDET			13
M	:98a:	Settlement Date/Time	A,B or C	SETT	1.8.23	16
O	:98a:	Trade Date/Time	A,B or C	TRAD	1.8.23	16

M	:35B:	Identification of the Financial Instrument	[ISIN1!e12!c][4*35x]		1.8.13	18
Optional Subsequence B1 Financial Instrument Attributes (not considered)						
M	:16S:	End of Block	TRADDET			37
End of Sequence B Settlement Transaction Details						
Mandatory Repetitive Sequence C Financial Instrument/Account						
M	:16R:	Start of Block	FIAC			38
M	:36B:	Quantity of Financial Instrument	:4!c//4!c/15d	SETT	1.8.14	39
O	:95a:	Party/Account Owner	P or R	ACOW	1.8.21	42
M	:97a:	Account	A or B	SAFE	1.8.22	43
M	:16S:	End of Block	FIAC			52
End of Sequence C Financial Instrument/Account						
Optional Sequence D Two Leg Transaction Details (not considered)						
Mandatory Sequence E Settlement Details						
M	:16R:	Start of Block	SETDET			62
M	:22F:	Indicator	:4!c/[8c]/4!c	SETR	1.8.8	63
Mandatory Repetitive Subsequence E1 Settlement Parties						
M	:16R:	Start of Block	SETPRTY			64
M	:95a:	Place of Settlement	C, P or Q	PSET	1.8.21	65
M	:95a:	Delivering Agent	P, Q or R	DEAG	1.8.21	65
O	:95a:	Seller	P, Q or R	SELL	1.8.21	65
O	:95a:	Buyer	P, Q or R	BUYR	1.8.21	65
O	:97a:	Safekeeping Account	A or B	SAFE	1.8.22	66
O	:70a:	Narrative	C, D or E	:4!c	1.8.16	69
M	:16S:	End of Block	SETPRTY			70
End of Subsequence E1 Settlement Parties						
Optional Repetitive Subsequence E2 Cash Parties (not considered)						
Optional Repetitive Subsequence E3 Amount (not considered)						
M	:16S:	End of Block	SETDET			81
End of Sequence E Settlement Details						
Optional Repetitive Sequence F Other Parties (not considered)						

2.1.2 Example of an instruction to receive securities as a result of internal movement within a Depository/Custodian

Example 1.

This is an example of an instruction to receive securities into an account with a Depository/Custodian from another account with the same Depository/Custodian.

Instruction number – KL00412/A-861.

Requested Settlement date when the securities are to be moved – the 23rd of September 2004.

Trade date – the 16th of September 2004.

Financial Instrument is defined by the following details:

- ISIN RU0008959655
- Narrative description of RAO EeS securities (Russia) with transliteration indicator – ‘RAOEeS.

The rules of financial instrument’s indication are defined in section 1.8.13 of this document.

Quantity of financial instrument to be settled – 1500 units.

Account number for money transaction - 1111

Type of Settlement Transaction – settlement of a trade, indicator SETR//TRAD.

Name of the owner of the nominal holder’s safekeeping account from which the securities should be delivered – ABC Broker, (BIC BROKRUMM, account number 2222).

Transaction basis is the contract of purchase and sale №45HII-1 dated the 16th of September 2004 and signed by the Seller and the Buyer. Russian letters in the contract number should be transliterated. Place of Settlement is a depository (BIC DEPORUMM) that services the accounts of the sender of the message OAO CB “Telecom” (account number 1111) and its agent ABC Broker (account number 2222, BIC BROKRUMM)

Message flow.

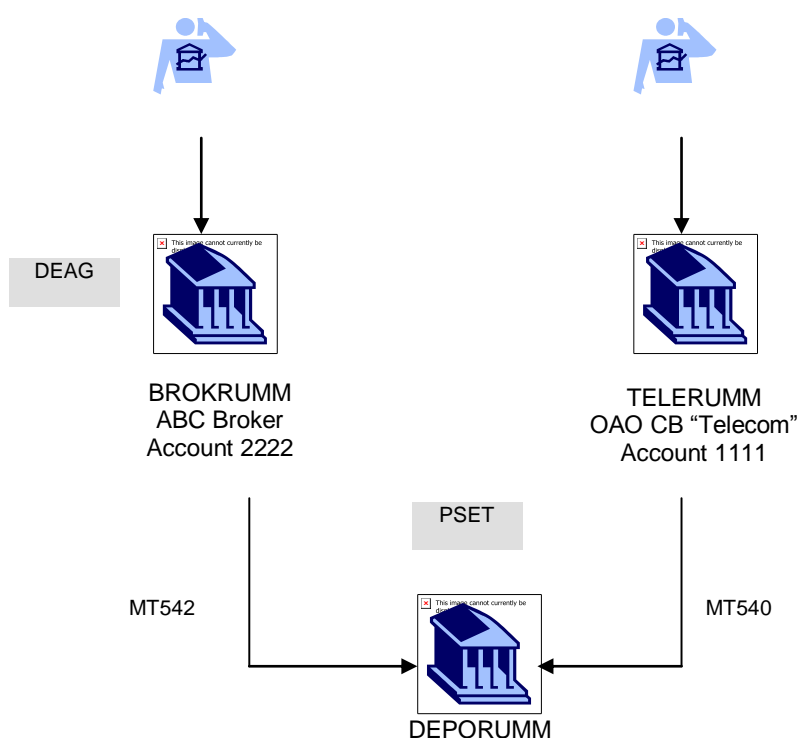

Sender of MT540 TELERUMM
Receiver of MT540 DEPORUMM

Message structure.

:16R:GENL
:20C::SEME//KL00412/A-861
:23G:NEWM
:16S:GENL
:16R:TRADDET
:98A::SETT//20040923
:98A::TRAD//20040916
:35B:ISIN RU0008959655
'RAO EeS
:16S:TRADDET
:16R:FIAC
:36B::SETT//UNIT/1500,
:97A::SAFE//1111NM
:16S:FIAC
:16R:SETDET
:22F::SETR//TRAD
:16R:SETPRTY
:95P::PSET//DEPORUMM
:16S:SETPRTY
:16R:SETPRTY
:95P::DEAG//BROKRUMM
:97A::SAFE//2222
:70E::DECL//TYPE/BYSA/NUMB/45'NP-1'/DATE/20040916
:16S:SETPRTY
:16S:SETDET

2.1.3. Examples of instructions to receive securities from an account serviced by an external party

Example 1.

This is an example of an instruction to receive securities into an account with Depository/Custodian from an account in the Registrar.

Instruction number – ANF-34/DF.

Settlement date when the securities are to be credited – the 23rd of September 2004.

Trade date – the 21st of September 2004.

Financial Instrument is defined by the following details:

- National state registration number 2-07-03-00345-A
- Corporate identifier 54327RT assigned by the Depository that services the Client's account
- Narrative description of ordinary shares of the third issue OAO "X-neft" with transliteration indicator – 'OAO "IKS-NEFTX" AO3.

Quantity of financial instrument to be settled – 8000 units.

Safekeeping account to be credited – 1111NM, account of the nominal holder OAO CB “Telecom”.

Type of Settlement Transaction – securities movement with Change of Beneficial Ownership, indicator SETR//TRAD.

Place of Settlement is the institution which is keeping the Register, Place of Settlement code - REGISTRAR.

Name of the owner of the account in the registrar from which the securities are moved – ZAO Company “Alliance”, its account number is not indicated in this example.

Type of the account with the Registrar to be debited – nominal holder’s account.

Transaction basis is the depository contract №25 dated the 14th of September 2004 and the contract of purchase and sale №RT12345 dated the 21st of May 2004.

Message flow.

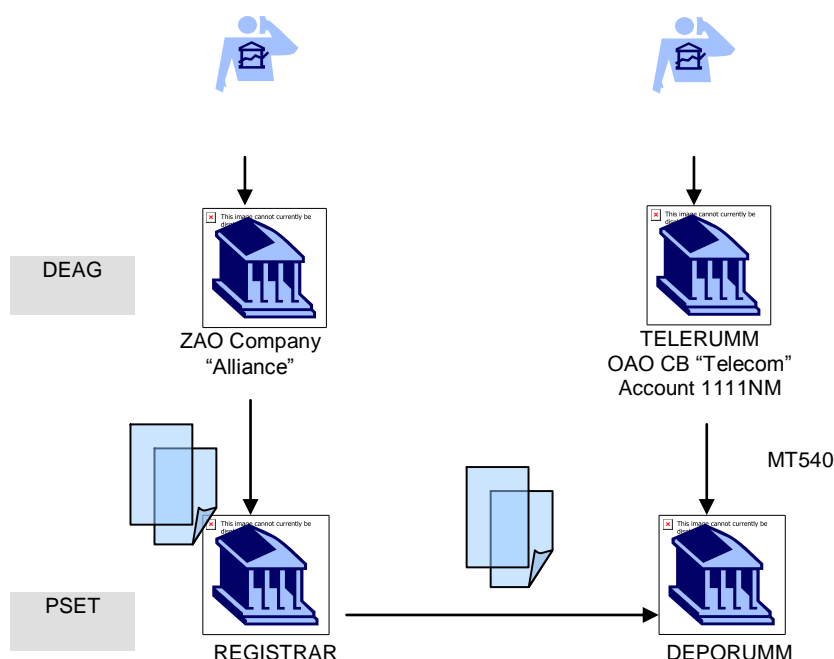

Place of Settlement is the registrar where the nominal holder ZAO Company “Alliance” has an account. OAO CB “Telecom” instructs the Depository (BIC DEPORUMM) that services its nominal holder’s account №1111NM to receive securities from the account of ZAO Company “Alliance” in the registrar.

Sender of MT540 TELERUMM

Receiver of MT540 DEPORUMM

Message structure.

```
:16R:GENL
:20C::SEME//ANF-34/DF
:23G:NEWM
:16S:GENL
:16R:TRADDET
:98A::SETT//20040923
:98A::TRAD//20040921
:35B:/XX/CORP/DEPO/54327RT
/RU/2-07-03-00345-A
```

'OAO 'IKS-NEFTX' AO3
:16S:TRADDET
:16R:FIAC
:36B::SETT//UNIT/8000,
:97A::SAFE//1111NM
:16S:FIAC
:16R:SETDET
:22F::SETR//TRAD
:16R:SETPRTY
:95Q::PSET//REGISTRAR
:16S:SETPRTY
:16R:SETPRTY
:95Q::DEAG/'ZAO KOMPANIa'' ALLIANCE''
:70E::DECL//TYPE/DEPA/NUMB/25/DATE/20040914
TYPE/BYSA/NUMB/RT12345/DATE/20040521
:70D::PART//OWNT/NOMI
:16S:SETPRTY
:16S:SETDET

Example 2.

This is an example of an instruction to receive securities to an account with a Depository/Custodian without Change of Beneficial Ownership. The securities are debited from an account in the Registrar.

Instruction number – RT12345GAZ.

Settlement date when the securities are to be moved – the 19th of May 2004.

Trade date – the 21st of September 2004.

Financial Instrument is defined by the following details:

- ISIN RU0009034268
- National state registration number 1-01-00029-A.

Narrative description of securities is not used in the current example.

The rules of financial instrument's indication are defined in section 1.8.5 of this document.

Quantity of financial instrument to be settled – 3000 units.

Safekeeping account to be credited – 1111NM.

Type of Settlement Transaction – securities movement without Change of Beneficial Ownership, indicator SETR//OWNE.

Place of Settlement is the institution which is the Registrar Holder, Place of Settlement code - REGISTRAR.

Name of the owner of the account in the registry from which the securities are moved – OAO "Telestar", its account number is not indicated in this example.

Type of the account with the Registrar to be debited – owner's account.

Transaction basis is the depository contract № 134 dated the 1st of February 2002.

Message flow.

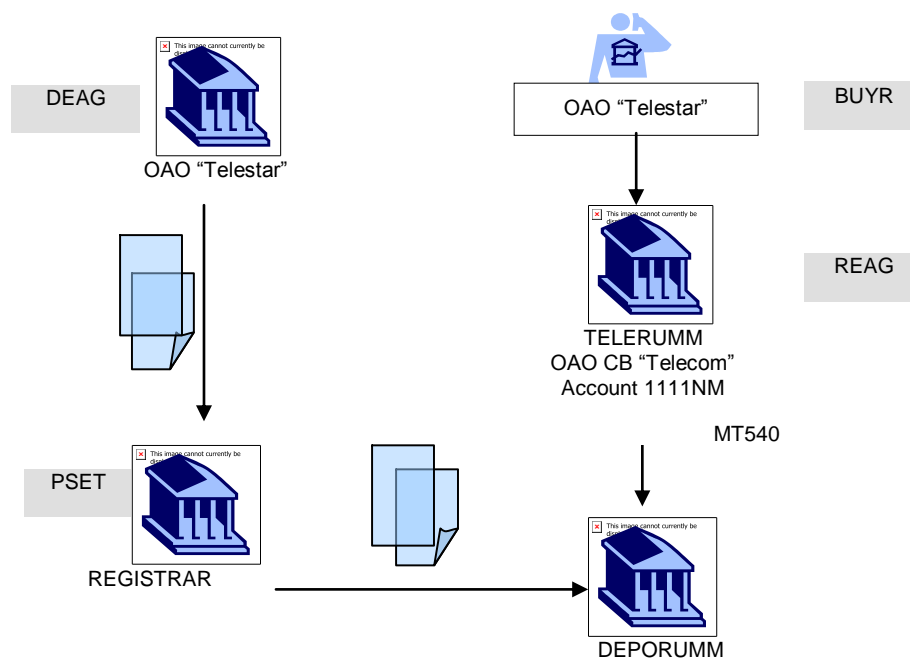

Place of Settlement is the Registrar where the owner OAO "Telestar" has an account. The bank OAO CB "Telecom" (BIC TELERUMM) instructs the Depository (BIC DEPORUMM) that services its nominal holder's account №1111NM to receive securities from the account of OAO "Telestar" in the registrar.

Sender of MT540 TELERUMM
Receiver of MT540 DEPORUMM

Message structure.

```
:16R:GENL
:20C::SEME//RT12345GAZ
:23G:NEWM
:16S:GENL
:16R:TRADDET
:98A::SETT//20040519
:35B:ISIN RU0009034268
/RU/1-01-00029-A
:16S:TRADDET
:16R:FIAC
:36B::SETT//UNIT/3000,
:97A::SAFE//1111NM
:16S:FIAC
:16R:SETDET
:22F::SETR//OWNE
:16R:SETPRTY
:95Q::PSET//REGISTRAR
:16S:SETPRTY
:16R:SETPRTY
:95Q::DEAG//"OAO "TELESTAR"
:70E::DECL//TYPE/DEPA/NUMB/134/DATE/20020201
```

:70D::PART//OWNT/OWNE
:16S:SETPRTY
:16S:SETDET

Example 3.

This is an example of an instruction which is used to receive securities into an account with national Depository from an account with another national Depository (“bridge”). There are appropriate bilateral agreements between two Depositories.

Instruction number – AL/123.

Settlement date when the securities are to be moved – the 18th of March 2004.

Trade date – the 15th of March 2004.

Financial Instrument is defined by the following details:

- ISIN RU0008959655
- Narrative description of RAO EeS securities (Russia) with transliteration indicator – ‘RAOEeS.

Quantity of financial instrument to be settled – 12378 units.

Safekeeping account to be credited – 2222.

Type of Settlement Transaction – settlement of a trade, indicator SETR//TRAD.

Place of Settlement is the correspondent Depository that services the account from which the securities are moved, BIC CUSTRUMM.

Name of the institution that owns the account at the correspondent Depository - OAO “United Funds”; according to bilateral agreement between the Depository and the account owner the account owner is identified using BIC - FONDRUMM.

Institution’s account number to be debited – MS1238ND, code of the safekeeping account’s section (sub- safekeeping account) - 30MC0009900010A00.

Transaction basis is the depository contract without number dated the 12th of May 2002 and intra-depository contract №543FD dated the 12th of February 2002.

Message flow.

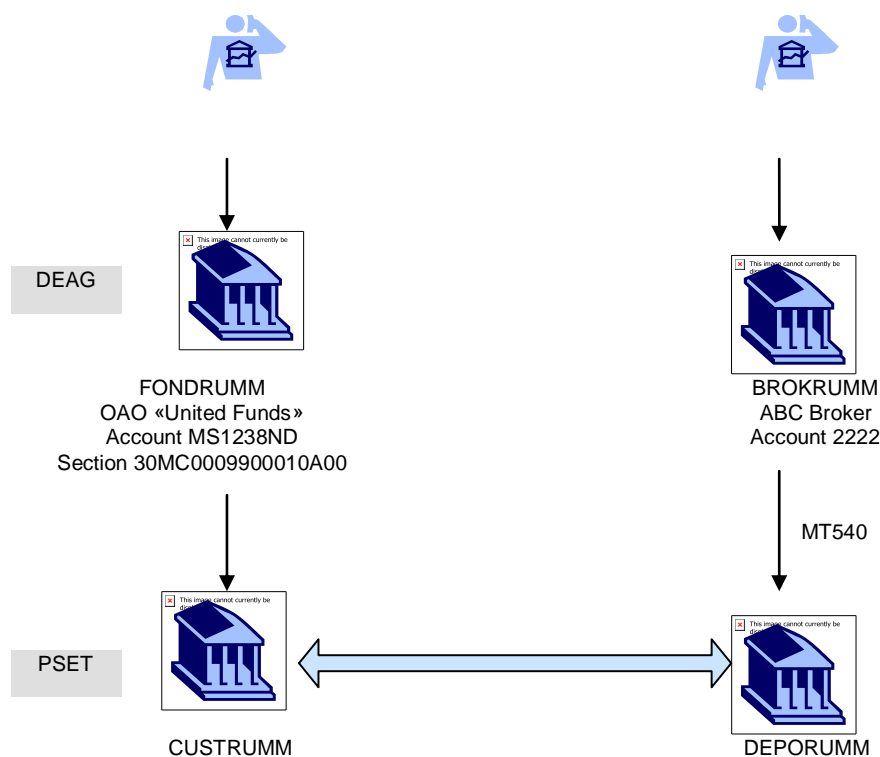

Place of Settlement is the correspondent Depository CUSTRUMM that services the account MS1238ND of OAO “United Funds”.

The investment manager ABC Broker (BIC BROKRUMM) instructs the Depository (BIC DEPORUMM) that services its nominal holder’s account 2222 to receive securities from the account of OAO “United Funds” (BIC FONDRUMM) at the correspondent Depository.

Sender of MT540 BROKRUMM

Receiver of MT540 DEPORUMM

Message structure.

:16R:GENL
:20C::SEME//AL/123
:23G:NEWM
:16S:GENL
:16R:TRADDET
:98A::SETT//20040318
:98A::TRAD//20040315
:35B:ISIN RU0008959655
‘RAO EeS
:16S:TRADDET
:16R:FIAC
:36B::SETT//UNIT/12378,
:97A::SAFE//2222
:16S:FIAC
:16R:SETDET
:22F::SETR//TRAD

:16R:SETPRTY
:95P::PSET//CUSTRUMM
:16S:SETPRTY
:16R:SETPRTY
:95P::DEAG//FONDRUMM
:97A::SAFE//MS1238ND/KRZD/30MC0009900010A00
:70E::DECL//TYPE/DEPA/NUMB/B/N/DATE/20020512/
TYPE/INDA/NUMB/543FD/DATE/20040212
:16S:SETPRTY
:16S:SETDET

Description and message flow related to turnaround (back-to-back) instruction MT542 Deliver Free sent to the correspondent Depository CUSTRUMM are provided in Example 3 section 2.3.2 of the current Guide.

2.2 MT541 RECEIVE AGAINST PAYMENT

This message is sent by an account owner to an account servicer (account servicing institution). This message is used to:

- instruct the receipt of financial instruments against payment, physically or by book-entry, from a specified party (the function of the message is NEWM)
- request the cancellation of a receive against payment instruction previously sent by the account owner (the function of the message is CANC)
- pre-advise the account servicer of a forthcoming receive against payment instruction (the function of the message is PREA).

2.2.1. Format Specifications

Status	Tag	Detailed Field Name	Content/Options	Qualifier	№ RUS	№ SWIFT User Handbook
Mandatory Sequence A General Information						
M	:16R:	Start of Block	GENL			1
M	:20C:	Sender's Message Reference	:4!c//16x	SEME	1.8.6	2
M	:23G:	Function of the Message	4!c/[4!c]		1.8.9	3
O	:98a:	Preparation Date/Time	A,C or E	PREP	1.8.4	4
Optional Repetitive Subsequence A1 Linkages						
M	:16R:	Start of Block	LINK			6
M	:20C:	Linked Message Reference	:4!c//16x	:4!c	1.8.7	9
M	16S:	End of Block	LINK			11
End of Subsequence A1 Linkages						
M	:16S:	End of Block	GENL			12
End of Sequence A General Information						
Mandatory Sequence B Trade Details						
M	:16R:	Start of Block	TRADEDET			13
M	:98a:	Settlement Date/Time	A,B or C	SETT	1.8.23	15
O	:98a:	Trade Date/Time	A,B or C	TRAD	1.8.23	15
M	:35B:	Identification of the Financial Instrument	[ISIN!e12!c][4*35x]		1.8.13	18
Optional Subsequence B1 Financial Instrument Attributes (not considered)						
M	:16S:	End of Block	TRADEDET			37

End of Sequence B Settlement Transaction Details						
M	:16R:	Start of Block	FIAC			38
M	:36B:	Quantity of Financial Instrument	:4!c//4!c/15d	SETT	1.8.14	39
Mandatory Repetitive Sequence C Financial Instrument/Account						
O	:95a:	Party/Account Owner	P or R	ACOW	1.8.21	42
M	:97a:	Safekeeping Account	A or B	SAFE	1.8.22	43
O	:97a:	Account	A or E	CASH	1.8.22	43
M	:16S:	End of Block	FIAC			52
End of Sequence C Financial Instrument/Account						
Optional Sequence D Two Leg Transaction Details (not considered)						
Mandatory Sequence E Settlement Details						
M	:16R:	Start of Block	SETDET			62
M	:22F:	Indicator	:4!c/[8c]/4!c	SETR	1.8.8	63
Mandatory Repetitive Subsequence E1 Settlement Parties						
M	:16R:	Start of Block	SETPRTY			64
M	:95a:	Place of Settlement	C, P or Q	PSET	1.8.21	65
M	:95a:	Delivering Agent	P, Q or R	DEAG	1.8.21	65
O	:95a:	Party/Seller	P, Q or R	SELL	1.8.21	65
O	:95a:	Party/Buyer	P, Q or R	BUYR	1.8.21	65
O	:97a:	Safekeeping Account	A or B	SAFE	1.8.22	66
O	:70a:	Narrative	C, D or E	:4!c	1.8.16	69
M	:16S:	End of Block	SETPRTY			70
End of Subsequence E1 Settlement Parties						
Optional Repetitive Subsequence E2 Cash Parties						
M	:16R:	Start of Block	CSHPRTY			71
M	:95a:	Party	P, Q or R	:4!c	1.8.21	72
O	:97a:	Account	A or E	CASH	1.8.22	73
M	:16S:	End of Block	CSHPRTY			74
End of Subsequence E2 Cash Parties						
Mandatory Repetitive Subsequence E3 Amount (not considered)						
M	:16R:	Start of Block	AMT			76
M	:19A:	Amount	:4!c//[N]3!a15 d	SETT	1.8.5	78
O	:98a:	Value Date/Time	A or C	VALU	1.8.23	80
M	:16S:	End of Block	AMT			81
End of Subsequence E3 Amount						
M	:16S:	End of Block	SETDET			82
End of Sequence E Settlement Details						
Optional Repetitive Sequence F Other Parties (not considered)						

2.2.2. Example of an instruction to receive securities against payment within a Depository

This is an example of an instruction which can be used to receive securities as a result of internal transfer between accounts with a Depository/Custodian, while cash accounts are serviced by a settlement bank and there are appropriate bilateral agreements between the bank and the Depository.

This scheme can be used by a Depository not licensed for banking transactions.

Instruction number – TEN004-346A.

Settlement date when the securities are to be moved – the 23rd of September 2004.

Trade date – the 16th of September 2004.

Financial Instrument is defined by the following details:

- ISIN RU0009024277
- Narrative description of NK Lukoil securities with transliteration indicator – ‘NK LUKOIL.

The rules of financial instrument’s indication are defined in section 1.8.13 of this document.

Quantity of financial instrument to be settled – 4000 units.

The Receiver of the securities is OAO CB “Telecom” (BIC TELERUMM); safekeeping account number to which the securities are to be credited – 1111NM, cash account number with the settlement bank to be debited – 001USB.

Type of Settlement Transaction – settlement of a trade, indicator SETR//TRAD.

Place of Settlement is the institution, that services the safekeeping accounts to which the securities are to be moved, BIC DEPORUMM.

Name of the owner of the account from which the securities are moved – ABC Broker, account number 2222, BIC BROKRUMM. This institution is also the Receiver of the cash amount.

Transaction basis is the contract of purchase and sale №675/003 dated the 16th of September 2004.

Bank servicing the account of the Receiver of the cash amount is USBank, BIC BANKRUMM.

Receiver’s account number with this bank – 002USB.

Total cash amount to be paid for the securities – 100000 US dollars.

Message flow.

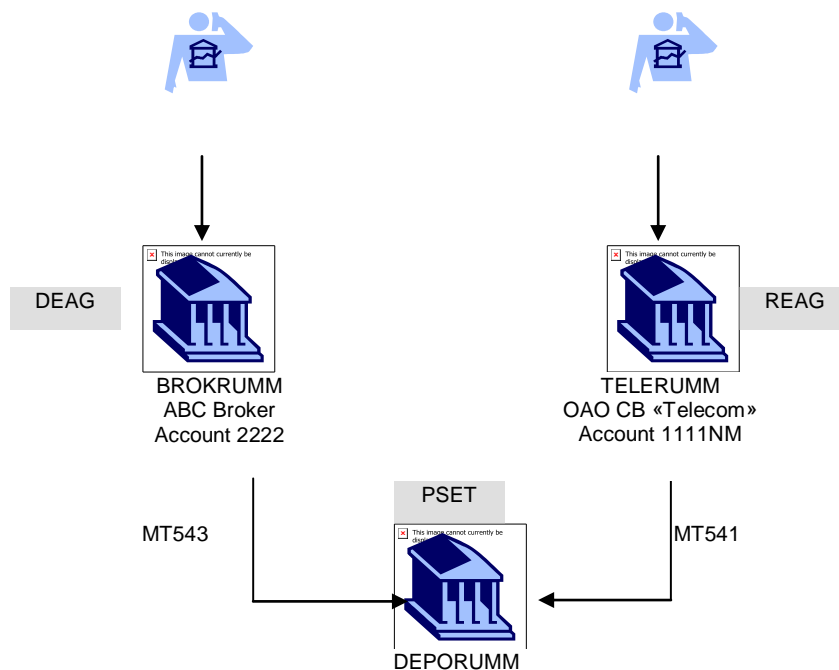

Place of Settlement is the Depository (BIC DEPORUMM) that services the accounts of the message's Sender (OAO CB «Telecom», account number 1111NM) and its counterparty (ABC Broker, account number 2222, BIC BROKRUMM).

Sender of MT541 TELERUMM
Receiver of MT541 DEPORUMM

Message structure.

```
:16R:GENL
:20C::SEME//TEN004-346A
:23G:NEWM
:16S:GENL
:16R:TRADDET
:98A::SETT//20040923
:98A::TRAD//20040916
:35B:ISIN RU0009024277
`NK LUKOIL
:16S:TRADDET
:16R:FIAC
:36B::SETT//UNIT/4000,
:97A::SAFE//1111NM
:97A::CASH//001USB
:16S:FIAC
:16R:SETDET
:22F::SETR//TRAD
:16R:SETPRTY
:95P::PSET//DEPORUMM
:16S:SETPRTY
:16R:SETPRTY
:95P::DEAG//BROKRUMM
```

:97A::SAFE//2222
:70E::DECL//TYPE/BYSA/NUMB/675/003/DATE/20040916
:16S:SETPRTY
:16R:CSHPRTY
:95P::ACCW//BANKRUMM
:16S:CSHPRTY
:16R:CSHPRTY
:95P::BENM//BROKRUMM
:97A::CASH//002USB
:16S:CSHPRTY
:16R:AMT
:19A::SETT//USD100000,
:16S:AMT
:16S:SETDET

2.2.3. Example of an instruction to receive securities against payment within a Depository-Bank

Example 1.

This is an example of an instruction which can be used to receive securities as a result of internal transfer between accounts with a Depository/Custodian, while cash accounts are serviced by the same financial institution.

This scheme can be used by a Depository-Bank.

Instruction number – AMT1234/541.

Settlement date when the securities are to be moved – the 13th of September 2004.

Trade date – the 6th of September 2004.

Financial Instrument is defined by the following details:

- ISIN RU0009034268
- National state registration number 1-01-00029-A
- Narrative description of OAO ‘GAZ’ securities with transliteration indicator – ‘OAO ‘GAZ’.

The rules of financial instrument’s indication are defined in section 1.8.5 of this document.

Quantity of financial instrument to be settled – 5000 units.

Type of Settlement Transaction – settlement of a trade, indicator SETR//TRAD.

Place of Settlement is the USBank’s depository, BIC BANKRUMM, that services:

Seller’s and Buyer’s accounts to be credited/debited with securities;

Seller’s and Buyer’s cash accounts.

The Receiver of the securities is OAO CB “Telecom” (BIC TELERUMM); safekeeping account number with which the securities are to be received – 54321, cash account number to be debited – 001USB.

Name of the owner of the account from which the securities are moved – ABC Broker, safekeeping account number - 98765, BIC BROKRUMM. This institution is the Receiver of the cash amount, account number to be credited – 002USB.

Transaction basis is the contract of purchase and sale № 123/003 dated the 6th of September 2004.

Total cash amount to be paid for the securities – 52000 US dollars 48 cents.

Message flow.

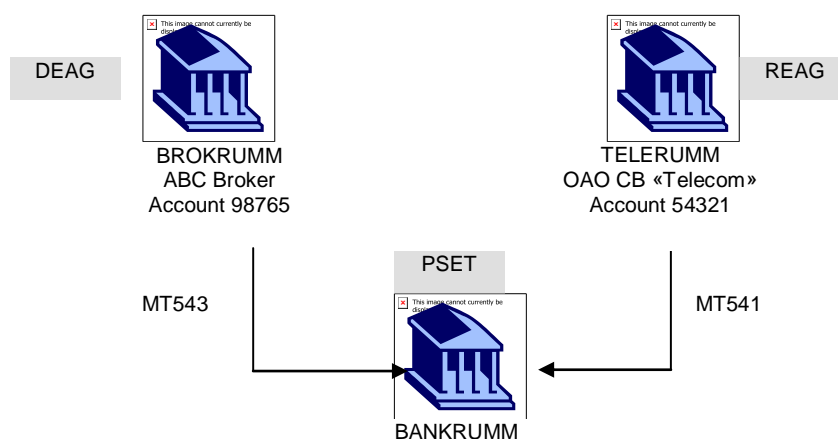

Place of Settlement is the Depository USBank (BIC BANKRUMM) that services the accounts of the message's Sender (OAO CB "Telecom", BIC TELERUMM) and its counterparty (ABC Broker, BIC BROKRUMM).

Sender of MT541 TELERUMM
Receiver of MT541 BANKRUMM

Message structure.

```
:16R:GENL
:20C::SEME//AMT1234/541
:23G:NEWM
:16S:GENL
:16R:TRADDET
:98A::SETT//20040913
:98A::TRAD//20040906
:35B:ISIN RU0009034268
/RU/1-01-00029-A
'AOA "GAZ"
:16S:TRADDET
:16R:FIAC
:36B::SETT//UNIT/5000,
:97A::SAFE//54321
:97A::CASH//001USB
:16S:FIAC
```

:16R:SETDET
:22F::SETR//TRAD
:16R:SETPRTY
:95P::PSET//BANKRUMM
:16S:SETPRTY
:16R:SETPRTY
:95P::DEAG//BROKRUMM
:97A::SAFE//98765
:70E::DECL//TYPE/BYSA/NUMB/123/003/DATE/20040906
:16S:SETPRTY
:16R:CSHPRTY
:95P::BENM//BROKRUMM
:97A::CASH//002USB
:16S:CSHPRTY
:16R:AMT
:19A::SETT//USD52000,48
:16S:AMT
:16S:SETDET

2.3 MT542 DELIVER FREE

This message is sent by an account owner to an account servicer (account servicing institution). This message is used to:

- instruct the delivery of financial instruments free of payment, physically or by book-entry, from a specified party (the function of the message is NEWM)
- request the cancellation of a deliver free of payment instruction previously sent by the account owner (the function of the message is CANC).

2.3.1. Format Specifications

Status	Tag	Detailed Field Name	Content/Options	Qualifier	№ RUS	№ SWIFT User Handbook
Mandatory Sequence A General Information						
M	:16R	Start of Block	GENL			1
M	:20C:	Sender's Message Reference	:4!c//16x	SEME	1.8.6	2
M	:23G:	Function of the Message	4!c[/4!c]		1.8.9	3
O	:98a:	Preparation Date/Time	A,C or E	PREP	1.8.4	4
Optional Repetitive Subsequence A1 Linkages						
M	:16R:	Start of Block	LINK			6
M	:20C:	Linked Message Reference	:4!c//16x	:4!c	1.8.7	9
M	16S:	End of Block	LINK			11
End of Subsequence A1 Linkages						
M	:16S:	End of Block	GENL			12
End of Sequence A General Information						
Mandatory Sequence B Trade Details						
M	:16R:	Start of Block	TRADDET			13
M	:98a:	Settlement Date/Time	A,B or C	SETT	1.8.23	15
O	:98a:	Trade Date/Time	A,B or C	TRA D	1.8.23	15
M	:35B:	Identification of the Financial Instrument	[ISIN1!e12!c][4*35x]		1.8.13	18

Optional Subsequence B1 Financial Instrument Attributes (not considered)						
M	:16S:	End of Block	TRADDET			37
End of Sequence B Settlement Transaction Details						
Mandatory Sequence C Financial Instrument/Account						
M	:16R:	Start of Block	FIAC			38
M	:38B:	Quantity of the financial instrument	:4!c//4!c/15d	SETT	1.8.14	39
O	:95a:	Party/Account Owner	P or R	ACOW	1.8.12	42
M	:97a:	Safekeeping Account	A, B or E	SAFE	1.8.22	43
M	:16S:	End of Block	FIAC			52
End of Sequence C Financial Instrument/Account						
Optional Sequence D Two Leg Transaction Details (not considered)						
Mandatory Sequence E Settlement Details						
M	:16R:	Start of Block	SETDET			62
M	:22F:	Indicator	:4!c/[8c]/4!c	SETR	1.8.8	63
Mandatory Repetitive Subsequence E1 Settlement Parties						
M	:16R:	Start of Block	SETPRTY			64
M	:95a:	Place of Settlement	C, P or Q	PSET	1.8.21	65
M	:95a:	Delivering Agent	P, Q or R	REAG	1.8.21	65
O	:95a:	Party/Seller	P, Q or R	SELL	1.8.21	65
O	:95a:	Party/Buyer	P, Q or R	BUYR	1.8.21	65
O	:97a:	Safekeeping Account	A or B	SAFE	1.8.22	66
O	:70a:	Narrative	C, D or E	:4!c	1.8.16	60
M	:16S:	End of Block	SETPRTY			70
End of Subsequence E1 Settlement Parties						
Optional Repetitive Subsequence E2 Cash Parties (not considered)						
Mandatory Repetitive Subsequence E3 Amount						
M	:16R:	Start of Block	AMT			76
M	:19A:	Amount	:4!c//[N]3!a15d	SETT	1.8.5	77
M	:16S:	End of Block	AMT			80
End of Subsequence E3 Amount						
M	:16S:	End of Block	SETDET			81
End of Sequence E Settlement Details						
Optional Repetitive Sequence F Other Parties (not considered)						

2.3.2. Example of an instruction to deliver securities within a Depository/Custodian

This is an example of an instruction which can be used to deliver securities from an account with a Depository/Custodian, while the account to be credited with the securities is serviced by the same Depository/Custodian.

Instruction number – 234521/45NP-1.

Settlement date when the securities are to be moved – the 23rd of September 2004.

Trade date – the 16th of September 2004.

Financial Instrument is defined by the following details:

- ISIN RU0008959655
- Narrative description of RAO EeS securities (Russia) with transliteration indicator – ‘RAO EeS.

Quantity of financial instrument to be settled – 1500 units.

Safekeeping account to be debited – 2222.

Type of Settlement Transaction – settlement of a trade, indicator SETR//TRAD.

Place of Settlement is the institution that services the safekeeping accounts to be debited/credited with the securities, BIC DEPORUMM.

Name of the owner of the account to be credited with the securities - OAO CB “Telecom”, account number – 1111, BIC TELERUMM.

Transaction basis is the contract of purchase and sale №45HII-1 dated the 16th of September 2004. Russian letters in the contract number should be transliterated.

Place of Settlement is the Depository (BIC DEPORUMM) that services the accounts of the Sender of the message (ABC Broker, account number 2222, BIC BROKRUMM) and its counterparty (OAO CB “Telecom”, account number 1111, BIC TELERUMM).

Message flow.

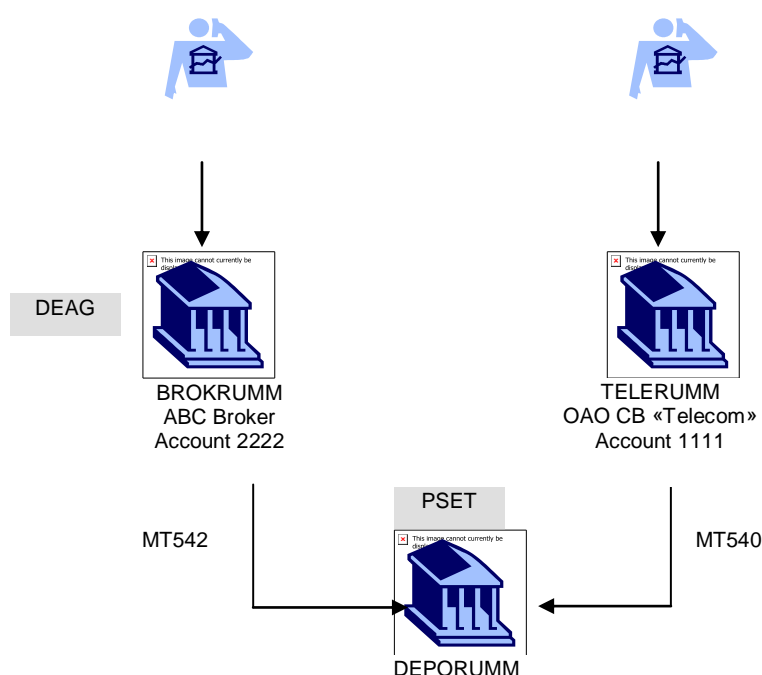

Sender of MT542 BROKRUMM
Receiver of MT542 DEPORUMM

Message structure.

:16R:GENL
:20C::SEME//234521/45NP-1
:23G:NEWM
:16S:GENL
:16R:TRADDET
:98A::SETT//20040423
:98A::TRAD//20040416
:35B:ISIN RU0098959655
'RAO EeS
:16S:TRADDET
:16R:FIAC
:36B::SETT//UNIT/1500,
:97A::SAFE//2222
:16S:FIAC
:16R:SETDET
:22F::SETR//TRAD
:16R:SETPRTY
:95P::PSET//DEPORUMM
:16S:SETPRTY
:16R:SETPRTY
:95P::REAG//TELERUMM
:97A::SAFE//1111
:70E::DECL//TYPE/BYSA/NUMB/45'NP-1'/DATE/20040916
:16S:SETPRTY
:16S:SETDET

2.3.3. Examples of instructions to deliver securities into an account serviced by a third party

Example 1.

This is an example of an instruction which can be used for moving portfolio and for changing the nominal holder in the Registrar - for moving securities from an account with a Depository/Custodian to an account in a registry.

Instruction number – SAMP542/NOM.

Settlement date when the securities are to be moved – the 23rd of September 2004.

Trade date is not indicated.

Financial Instrument is defined by the following details:

- National state registration number 1-03-00161-A
- Corporate identifier 54327RT
- Narrative description of ordinary shares of the third issue OAO “Tatneft” with transliteration indicator – ‘OAO “TATNEFTX” AO3.

The rules of financial instrument's indication are defined in section 1.8.5 of this document.

Quantity of financial instrument to be settled – 8000 units.

Safekeeping account to be debited – 1111NM.

Type of Settlement Transaction – securities movement without Change of Beneficial Ownership, indicator SETR//OWNE.

Place of Settlement is the institution which is the Registrar keeping the registry, Place of Settlement code - REGISTRAR.

Name of the owner of the account in the registrar to which the securities are moved – ZAO Company “Alliance”, its account number is not indicated in this example.

Type of the account with the Registrar to be credited – nominal holder's account.

Transaction basis is the depository contract №10 dated the 12th of March 2004.

Details of the party, in the name of which the securities are re-registered:

Number of the registration document /NUMB/ - 1025501341252

Date of registration document's issuance /DATE/ - the 11th of May 2003

Institution that issued the registration document /REGA/ - Intra-district inspection of the Ministry of Internal Affairs of Russia № 25 for Moscow

Registration document code /TYPE/OGRN - certificate of making an entry in the Unified National Registrar of Juridical Persons.

Place of Settlement is the Registrar where the nominal holder ZAO Company “Alliance” has an account. OAO CB “Telecom”, which is the nominal holder of securities of OAO “Telestar”, instructs the Depository (BIC DEPORUMM) that services its nominal holder's account №1111NM to move the securities to the account of ZAO Company “Alliance” in the registrar.

Message flow.

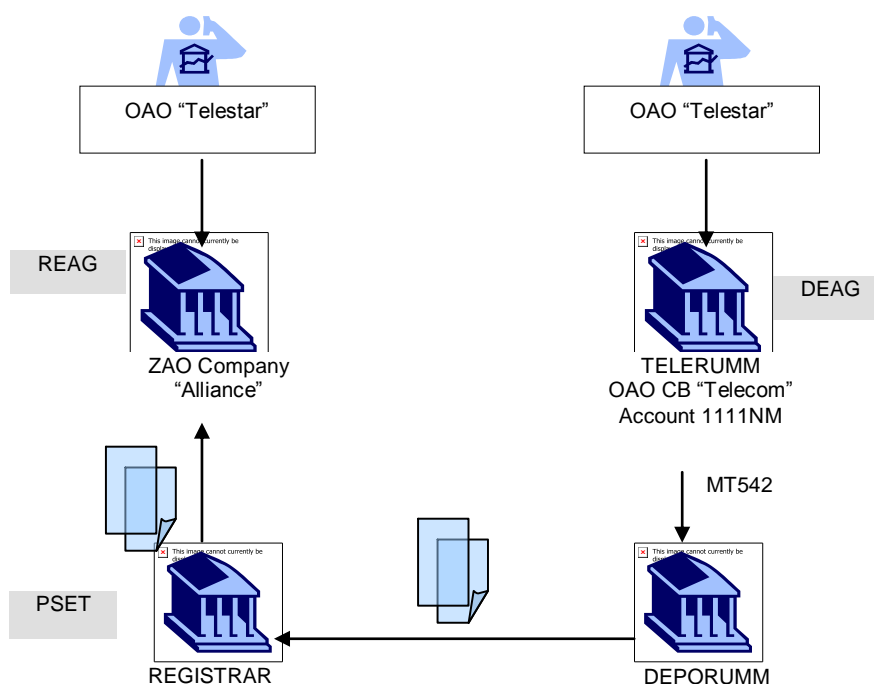

Sender of MT542 TELERUMM
Receiver of MT542 DEPORUMM

Message structure.

:16R:GENL
:20C::SEME//SAMP542/NOM
:23G:NEWM
:16S:GENL
:16R:TRADDET
:98A::SETT//20040923
:35B:/XX/CORP/DEPO/54327RT
/RU/1-03-00161-A
'OAO 'TATNEFTX' AO3
:16S:TRADDET
:16R:FIAC
:36B::SETT//UNIT/8000,
:97A::SAFE//1111NM
:16S:FIAC
:16R:SETDET
:22F::SETR//OWNE
:16R:SETPRTY
:95Q:PSET//REGISTRAR
:16S:SETPRTY
:16R:SETPRTY
:95Q::REAG/'ZAO KOMPANIa'' ALLIANCE''
:70E::DECL//TYPE/NOMA/NUMB/10/DATE/20040312
:70D::REGI//TYPE/OGRN/NUMB/1025501341252/DATE/2
0030511/REGA'MEJRAiONNAa INSPEKCI
a MNS ROSSII' N.25 'PO G.MOSKVE
:70D::PART//OWNT/NOMI
:16S:SETPRTY
:16S:SETDET

Example 2.

This is an example of an instruction to deliver securities from an account with a Depository/Custodian involving Change of Beneficial Ownership. Securities are credited to an account at the Registrar.

Instruction number – SAMP542/OWN.

Settlement date when the securities are to be moved – the 19th of September 2004.

Financial Instrument is defined by the following details:

- ISIN RU0009034268
- National state registration number 1-01-00029-A
- Narrative description of OAO "GAZ" securities with transliteration indicator – 'OAO "GAZ"'.

The rules of financial instrument's indication are defined in section 1.8.5 of this document.

Quantity of financial instrument to be settled – 3000 units.

Safekeeping account with the Depository/Custodian to be debited – 1111NM.

Type of Settlement Transaction – securities movement with Change of Beneficial Ownership, indicator - SETR//TRAD.

Place of Settlement is the institution which is the Register Holder, Place of Settlement code - REGISTRAR.

Name of the owner of the account in the registry to which the securities are moved – OAO “Telestar”, its account number is not indicated in this example.

Type of the account at the Registrar to be credited – owner’s account.

Amount to be paid for the securities – 10000 US dollars.

Transaction basis is:

the depository contract №134 dated the 1st of February 2002;

the contract of purchase and sale № RT12345 dated the 11th of September 2004.

Details of the party, in the name of which the securities are re-registered:

Number of the registration document /NUMB/ - 011.208

Date of registration document’s issuance /DATE/ - the 29th of October 1999

Institution that issued the registration document /REGA/ - Registration Chamber of Moscow

Registration document code /TYPE/STIC – registration certificate.

Message flow.

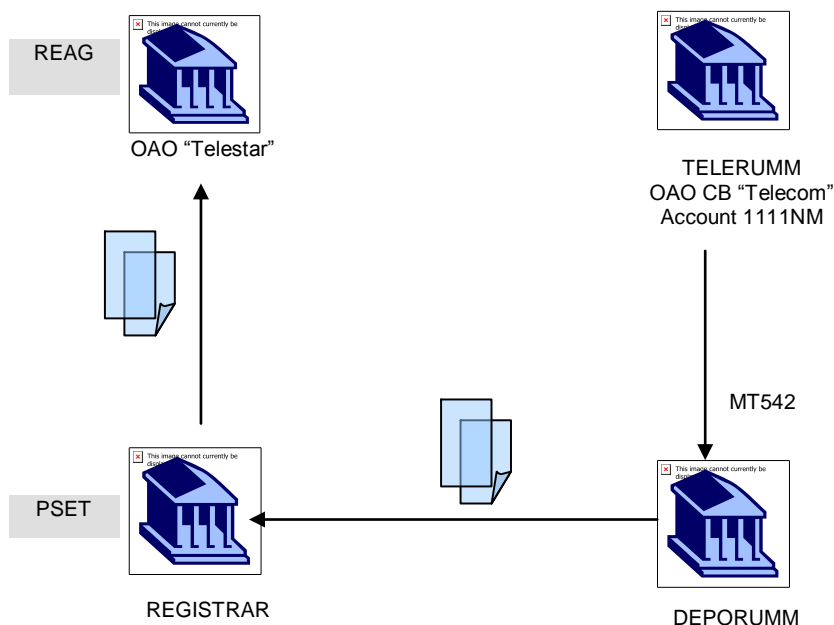

Place of Settlement is the Registrar where the owner OAO “Telestar” has an account. The bank OAO CB “Telecom” (BIC TELERUMM) instructs the Depository (BIC DEPORUMM) that services its nominal holder’s account №1111NM to move the securities to the account of the owner OAO “Telestar” in the registry.

Sender of MT542 TELERUMM
Receiver of MT542 DEPORUMM

Message structure.

:16R:GENL
:20C::SEME//SAMP542/OWN
:23G:NEWM
:16S:GENL
:16R:TRADDET
:98A::SETT//20040919
:98A::TRAD//20040911
:35B:ISIN RU0009034268
/RU/1-01-00029-A
'OAO "GAZ"
:16S:TRADDET
:16R:FIAC
:36B::SETT//UNIT/3000,
:97A::SAFE//1111NM
:16S:FIAC
:16R:SETDET
:22F::SETR//TRAD
:16R:SETPRTY
:95Q::PSET//REGISTRAR
:16S:SETPRTY
:16R:SETPRTY
:95Q::REAG//"OAO "TELESTAR"
:70E::DECL//TYPE/DEPA/NUMB/134/DATE/20020201
/TYPE/BYSA/NUMB/RT12345/DATE/20040911
:70D::REGI//TYPE/STIC/NUMB/011.208/DATE/19991029/REGA/MRP
:70D::PART//OWNT/OWNE
:16S:SETPRTY
:16R:AMT
:19A::SETT//USD10000,
:16S:AMT
:16S:SETDET

Example 3.

This is an example of an instruction to deliver securities from an account with a national Depository to an account with another national Depository ("bridge"). There are appropriate bilateral agreements between the two Depositories.

Instruction number – AL/123.

Settlement date when the securities are to be moved – the 18th of March 2004.

Trade date – the 15th of March 2004.

Financial Instrument is defined by the following details:

- ISIN RU0008959655
- Narrative description of RAO EeS securities (Russia) with transliteration indicator – 'RAOEeS.

Quantity of financial instrument to be settled – 12378 units.

Safekeeping account to be debited – MS1238ND.

Type of Settlement Transaction –settlement of a trade, indicator SETR//TRAD.

Place of Settlement is the correspondent Depository that services the account to which the securities are moved, BIC DEPORUMM.

Name of the institution which is the owner of the account in the correspondent Depository - ABC Broker, account number to be credited – 2222.

Transaction basis is the depository contract without number dated the 12th of May 2002 and intra-depository contract №543FD dated the 12th of February 2002.

Message flow.

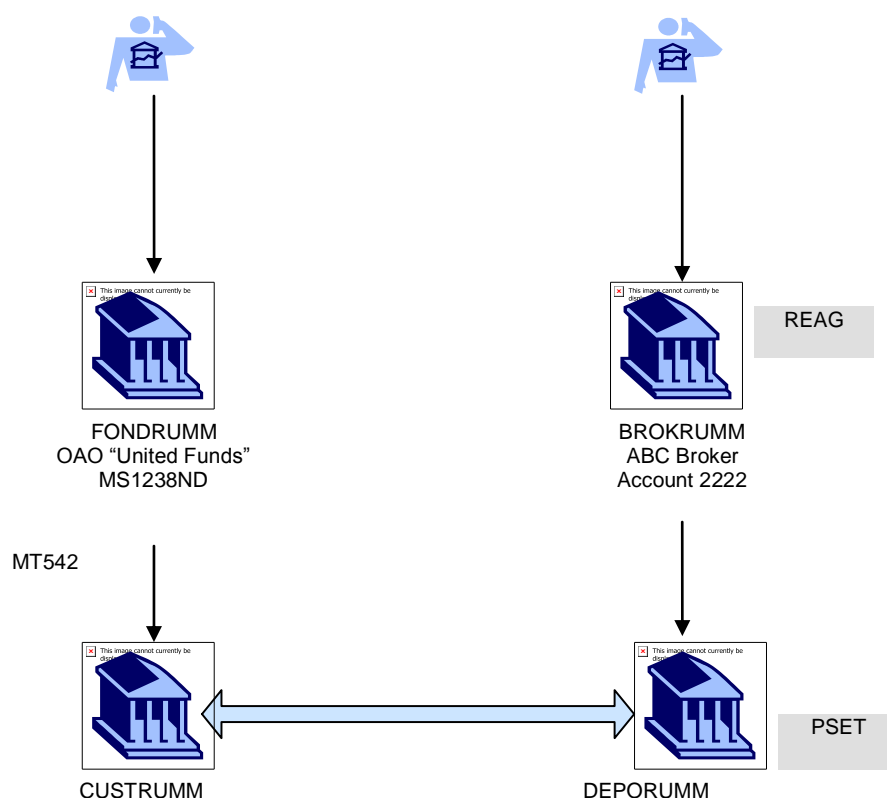

Place of Settlement is the correspondent Depository DEPORUMM that services the account 2222 of ABC Broker.

OAO "United Funds" (BIC FONDRUMM) instructs the Depository (BIC CUSTRUMM) to deliver securities from the account MS1238ND to the account 2222 of ABC Broker with the correspondent Depository.

Sender of MT542 BROKRUMM

Receiver of MT542 CUSTRUMM

Message structure.

:16R:GENL

:20C::SEME//AL/123

:23G:NEWM

:16S:GENL
 :16R:TRADDET
 :98A::SETT//20040318
 :98A::TRAD//20040315
 :35B:ISIN RU0008959655
 'RAO EeS
 :16S:TRADDET
 :16R:FIAC
 :36B::SETT//UNIT/12378,
 :97A::SAFE//MS1238ND
 :16S:FIAC
 :16R:SETDET
 :22F::SETR//TRAD
 :16R:SETPRTY
 :95P::PSET//DEPORUMM
 :16S:SETPRTY
 :16R:SETPRTY
 :95P::REAG//BROKRUMM
 :97A::SAFE//2222
 :70E::DECL//TYPE/DEPA//NUMB/B/N/DATE/20020512
 /TYPE/INDA/NUMB/543FD/DATE/20040212
 :16S:SETPRTY
 :16S:SETDET

Description and message flow related to matching instruction MT540 Receive Free sent to the correspondent Depository DEPORUMM are provided in Example 3 section 2.1.3 of the current Guide.

Example 4

This is an example of an instruction to deliver securities from an account with a Depository/Custodian involving Change of Beneficial Ownership.

Securities are credited into an account at the Registrar.

Depository-custodian has an account at the Registrar. At the same time it has an account in other depositories (CENDRUMM), which in turn has an account at the Registrar.

Delivery of securities in this case can be made using as an Agent - Depository CENDRUMM. To specify a complete delivery chain and the need of using as an agent of the depository CENDRUMM in the depository notification in addition to as an Agent for the delivery will be listed depository CENDRUMM.

Instruction number – SAMP542/OWN.

Settlement date when the securities are to be moved – the 19th of September 2004.

Financial Instrument is defined by the following details:

- ISIN RU0009034268
- National state registration number 1-01-00029-A
- Narrative description of OAO “GAZ” securities with transliteration indicator – ‘OAO “GAZ”’.

The rules of financial instrument's indication are defined in section 1.8.5 of this document.

Quantity of financial instrument to be settled – 3000 units.

Safekeeping account with the Depository/Custodian to be debited – 1111NM.

Type of Settlement Transaction – securities movement with Change of Beneficial Ownership, indicator - SETR//TRAD.

Place of Settlement is the institution which is the Register Holder, Place of Settlement code - REGISTRAR.

Name of the owner of the account in the registry to which the securities are moved – OAO “Telestar”, its account number is not indicated in this example.

Type of the account at the Registrar to be credited – owner's account.

Amount to be paid for the securities – 10000 US dollars.

Transaction basis are:

- the depository contract №134 dated the 1st of February 2002;
- the contract of purchase and sale № RT12345 dated the 11th of September 2004.
- Details of the party, in the name of which the securities are re-registered:
- Number of the registration document /NUMB/ - 011.208, date of registration document's issuance /DATE/ - the 29th of October 1999, institution that issued the registration document /REGA/ - Registration Chamber of Moscow
- Registration document in USRLE (Unified State Register of Legal Entities), code /TYPE/OGRN/ – registration certificate, number of the registration document /NUMB/ - 1234505432152, date of issuance /DATE/- the 30th of September 2001, institution that issued the registration document /REGA/ - Interdistrict Tax Inspectorate MTA № 26, Moscow

Message flow.

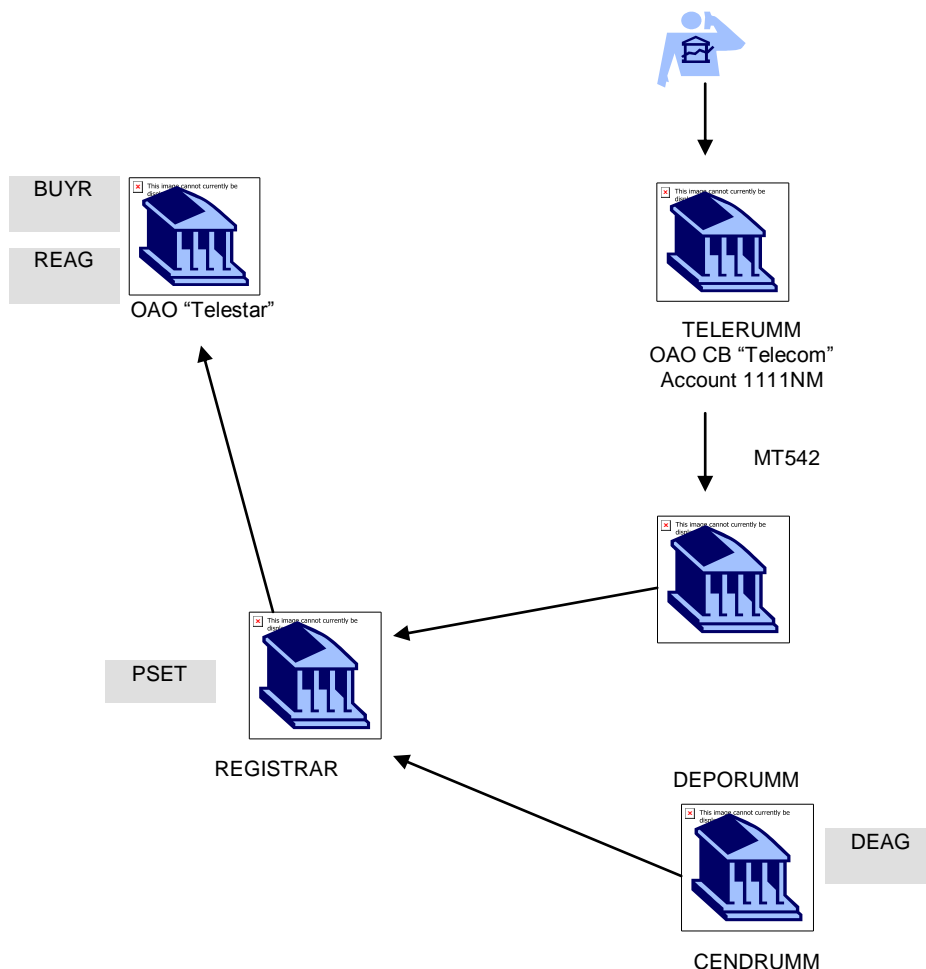

Place of Settlement is the Registrar.

The bank OAO CB "Telecom" (BIC TELERUMM) instructs the Depository (BIC DEPORUMM) that services its nominal holder's account №1111NM to move the securities to the account of the owner OAO "Telestar" in the registry.

In the depo instruction CENDRUMM Depository is specified as the delivery Agent (withdrawal of securities in the registrar will be executed from the CENDRUMM account).

Sender of MT542 TELERUMM
Receiver of MT542 DEPORUMM

Message structure.

```
:16R:GENL
:20C::SEME//SAMP542/OWN
:23G:NEWM
:16S:GENL
:16R:TRADDET
:98A::SETT//20040919
:98A::TRAD//20040911
:35B:ISIN RU0009034268
/RU/1-01-00029-A
```

'OAO "GAZ"
:16S:TRADDET
:16R:FIAC
:36B::SETT//UNIT/3000,
:97A::SAFE//1111NM
:16S:FIAC
:16R:SETDET
:22F::SETR//TRAD
:16R:SETPRTY
:95Q::PSET//REGISTRAR
:16S:SETPRTY
:16R:SETPRTY
:95P::DEAG//CENDRUMM
:16S:SETPRTY
:16R:SETPRTY
:95Q::REAG//"OAO "TELESTAR"
:70E::DECL//TYPE/DEPA/NUMB/134/DATE/20020201
PE/BYSA/NUMB/RT12345/DATE/20040911
:70D::REGI//TYPE/STIC/NUMB/011.208/DATE/19991029/REGA/MRP
TYPE/OGRN/NUMB/1234505432152/DATE/20
011130/REGA/'MEJRAiONNAa INSPEKCIa MNS ROSSII' N.26'PO G.MOSKVE
:70C::PACO//OWNT/OWNE
:16S:SETPRTY
:16R:SETPRTY
:95Q::BUYR//"OAO "TELESTAR"
:16S:SETPRTY
:16R:AMT
:19A::SETT//USD10000,
:16S:AMT
:16S:SETDET

2.4. MT543 DELIVER AGAINST PAYMENT

This message is sent by an account owner to an account servicer (account servicing institution). This message is used to:

- instruct the delivery of financial instruments against payment, physically or by book-entry, from a specified party (the function of the message is NEWM)
- request the cancellation of a deliver against payment instruction previously sent by the account owner (the function of the message is CANC).

2.4.1. Format Specification

Status	Tag	Detaild Field Name	Content/Options	Qualifier	Nº RUS	Nº SWIFT User Handbook
--------	-----	--------------------	-----------------	-----------	--------	------------------------

Mandatory Sequence A General Information

M	:16R:	Start of Block	GENL			1
M	:20C:	Sender's Message Reference	:4!c//16x	SEME	1.8.6	2
M	:23G:	Function of the Message	4!c[/4!c]		1.8.9	3
O	:98a:	Preparation Date/Time	A,C or E	PREP	1.8.4	4

Optional Repetitive Subsequence A1 Linkages

M	:16R:	Start of Block	LINK			6
M	:20C:	Linked Message Reference	:4!c//16x	:4!c	1.8.7	9
M	16S:	End of Block	LINK			10

End of Subsequence A1 Linkages

M	:16S:	End of Block	GENL			12
---	-------	--------------	------	--	--	----

End of Sequence A General Information

Mandatory Sequence B Trade Details

M	:16R:	Start of Block	TRADDET			13
M	:98a:	Settlement Date/Time	A,B or C	SETT	1.8.23	15
O	:98a:	Trade Date/Time	A,B or C	TRAD	1.8.23	15
M	:35B:	Identification of the Financial Instrument	[ISIN1!e12!c][4*35x]		1.8.13	18

Optional Subsequence B1 Financial Instrument Attributes (not considered)

M	:16S:	End of Block	TRADDET			37
---	-------	--------------	---------	--	--	----

End of Sequence B Settlement Transaction Details

Mandatory Repetitive Sequence C Financial Instrument/Account

M	:16R:	Start of Block	FIAC			38
M	:38B:	Quantity of the financial instrument	:4!c//4!c/15d	SETT	1.8.14	39

O	:95a:	Party/Account Owner	P or R	ACOW	1.8.21	42
M	:97a:	Safekeeping Account	A or B	SAFE	1.8.22	43
O	:97a:	Account/Cash account	A or E	CASH	1.8.22	43
M	:16S:	End of Block	FIAC			52
End of Sequence C Financial Instrument/Account						
Optional Sequence D Two Leg Transaction Details (not considered)						
Mandatory Sequence E Settlement Details						
M	:16R:	Start of Block	SETDET			62
M	:22F:	Indicator	:4!c/[8c]/4!c	SETR	1.8.8	63
Mandatory Repetitive Subsequence E1 Settlement Parties						
M	:16R:	Start of Block	SETPRTY			64
M	:95a:	Party/Place of Settlement	C, P or Q	PSET	1.8.21	65
M	:95a:	Party/Receiving agent	P, Q or R	REAG	1.8.21	65
O	:95a:	Party/Seller	P, Q or R	SELL	1.8.21	65
O	:95a:	Party/Buyer	P, Q or R	BUYR	1.8.21	65
O	:97a:	Safekeeping Account	A or B	SAFE	1.8.22	66
O	:70a:	Narrative	C, D or E		1.8.16	69
M	:16S:	End of Block	SETPRTY			70
End of Subsequence E1 Settlement Parties						
Optional Repetitive Subsequence E2 Cash Parties						
M	:16R:	Start of Block	CSHPRTY			71
M	:95a:	Party	P, Q or R		1.8.21	72
O	:97a:	Account/Cash account	A or E	CASH	1.8.22	73
M	:16S:	End of Block	CSHPRTY			74
End of Subsequence E2 Cash Parties						
Mandatory Repetitive Subsequence E3 Amount						
M	:16R:	Start of Block	AMT			76
M	:19A:	Amount	:4!c//[N]3!a1 5d	SETT	1.8.5	78
O	:98a:	Value Date/Time	A or C	VALU	1.8.23	80
M	:16S:	End of Block	AMT			81
End of Subsequence E3 Amount						
M	:16S:	End of Block	SETDET			82
End of Sequence E Settlement Details						
Optional Repetitive Sequence F Other Parties (not considered)						

2.4.2. Example of an instruction to deliver securities within a Depository/Custodian

This is an example of an instruction which can be used to deliver securities from an account with a Depository/Custodian, while the account to be credited with the securities is serviced by the same Depository/Custodian.

Instruction number – DVP040602/543.

Settlement date when the securities are to be moved – the 23rd of September 2004.

Trade date – the 16th of September 2004.

Financial Instrument is defined by the following details:

- ISIN RU0009024277
- Narrative description of NK Lukoil securities with transliteration indicator – ‘NK LUKOIL.

The rules of financial instrument’s indication are defined in section 1.8.5 of this document.

Quantity of financial instrument to be settled – 4000 units.

Safekeeping account to be debited – 2222.

Type of Settlement Transaction – settlement of a trade, indicator SETR//TRAD.

Place of Settlement is the institution that services the safekeeping accounts to be debited/credited with the securities, BIC DEPORUMM.

Name of the owner of the account to be credited with the securities – OAO CB “Telecom”, account number – 1111NM, BIC TELERUMM.

Transaction basis is the contract of purchase and sale №675/003 dated the 16th of September 2004.

Receiving party – ANC Broker, BIC BROKRUMM

Bank servicing the account of the Receiver of the cash amount is USBank, BIC BANKRUMM.

Receiver’s cash account number with this bank – 002USB.

Total cash amount to be paid for the securities – 100000 US dollars.

Message flow.

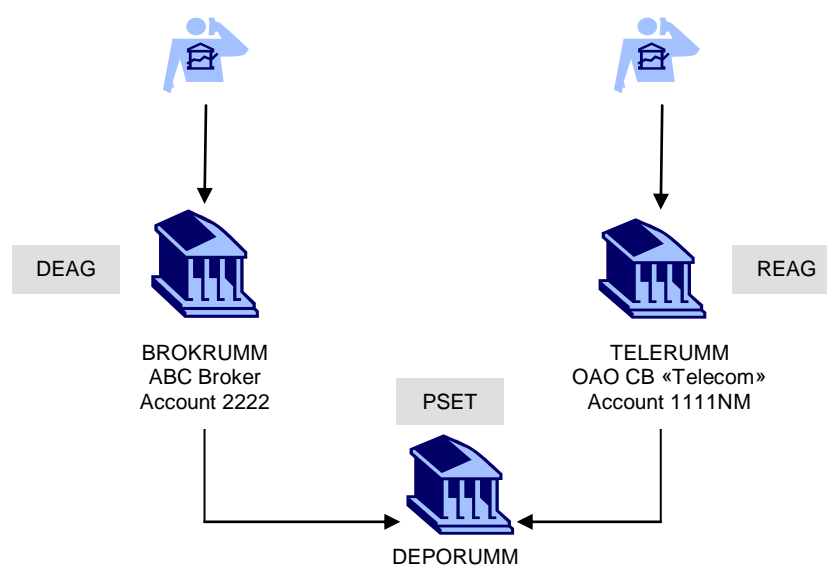

Place of Settlement is the Depository (BIC DEPORUMM) that services the accounts of the Sender of the message (ABC Broker, BIC BROKRUMM, account number 2222) and its counterparty (OAO CB “Telecom”, BIC TELERUMM, account number 1111NM).

Sender of MT543 BROKRUMM
Receiver of MT543 DEPORUMM

Message structure.

:16R:GENL
:20C::SEME//DVP040602/543
:23G:NEWM
:16S:GENL
:16R:TRADDET
:98A::SETT//20040923
:98A::TRAD//20040916
:35B:ISIN RU0009024277
‘NK LUKOIL
:16S:TRADDET
:16R:FIAC
:36B::SETT//UNIT/4000,
:97A::SAFE//2222
:97A::CASH//002USB
:16S:FIAC
:16R:SETDET
:22F::SETR//TRAD
:16R:SETPRTY
:95P::PSET//DEPORUMM
:16S:SETPRTY
:16R:SETPRTY
:95P::REAG//TELERUMM
:97A::SAFE//1111NM
:70E::DECL//TYPE/BYSA/NUMB/675/003/DATE/20040916
:16S:SETPRTY
:16R:CSHPRTY
:95P::ACCW//BANKRUMM
:16S:CSHPRTY
:16R:AMT
:19A::SETT//USD100000,
:16S:AMT
:16S:SETDET

3. FORMATS OF CONFIRMATIONS OF EXECUTION, STATEMENTS AND ADVICES RELATED TO SETTLEMENT INSTRUCTIONS' STATUS

3.1. MT544 RECEIVE FREE CONFIRMATION

This message is sent by an account servicer (account servicing institution) to an account owner or its designated agent. This message is used to:

- confirm the receipt of financial instruments free of payment, physically or by book-entry, from a specified party (the function of the message is NEWM)
- cancel a confirmation of a receipt free of payment previously sent by the account servicer (the function of the message is CANC)
- reverse a confirmation of a receipt free of payment previously sent by the account servicer (the function of the message is RVSL).

The message is also used to pre-confirm settlement or to confirm a partial settlement of a receipt of financial instruments free of payment.

3.1.1. Format Specifications

Status	Tag	Detailed Field Name	Content/Options	Qualifier	№ RUS	№ SWIFT User Handbook
Mandatory Sequence A General Information						
M	:16R:	Start of Block	GENL			1
M	:20C:	Sender's Message Reference	:4!c//16x	SEME	1.8.6	2
M	:23G:	Function of the Message	4!c[/4!c]		1.8.9	3
O	:98a:	Preparation Date/Time	A or C	PREP	1.8.23	4
Optional Repetitive Subsequence A1 Linkages						
M	:16R:	Start of Block	LINK			6
M	:20C:	Linked Message Reference	:4!c//16x	RELA	1.8.7	9
M	16S:	End of Block	LINK			10
End of Subsequence A1 Linkages						
M	:16S:	End of Block	GENL			11
End of Sequence A General Information						
Mandatory Sequence B Trade Details						
M	:16R:	Start of Block	TRADDET			12

M	:98a:	Effective Settlement Date/Time	A,B or C	ESET	1.8.23	14
O	:98a:	Settlement Date/Time	A,B or C	SETT	1.8.23	14
O	:98a:	Trade Date/Time	A,B or C	TRAD	1.8.23	14
M	:35B:	Identification of the Financial Instrument	[ISIN1!e12!c][4*35x]		1.8.13	17
Optional Subsequence B1 Financial Instrument Attributes (not considered)						
M	:16S:	End of Block	TRADDET			34
End of Sequence B Settlement Transaction Details						
Mandatory Repetitive Sequence C Financial Instrument/Account						
M	:16R:	Start of Block	FIAC			35
M	:36B:	Quantity of the financial instrument	:4!c//4!c/15d	SETT	1.8.14	36
O	:95a:	Party/Account Owner	P or R	ACOW	1.8.21	40
M	:97a:	Safekeeping Account	A or B	SAFE	1.8.22	41
M	:16S:	End of Block	FIAC			50
End of Sequence C Financial Instrument/Account						
Optional Sequence D Two Leg Transaction Details (not considered)						
Mandatory Sequence E Settlement Details						
M	:16R:	Start of Block	SETDET			60
M	:22F:	Indicator	:4!c/[8c]/4!c	SETR	1.8.8	61
Mandatory Repetitive Subsequence E1 Settlement Parties						
M	:16R:	Start of Block	SETPRTY			62
M	:95a:	Party/Place of Settlement	C, P or Q	PSET	1.8.21	63
M	:95a:	Party/Delivering agent	P, Q or R	DEAG	1.8.21	63
O	:95a:	Party/Seller	P, Q or R	SELL	1.8.21	63
O	:95a:	Party/Buyer	P, Q or R	BUYR	1.8.21	63
O	:97a:	Safekeeping Account	A or B	SAFE	1.8.22	64
O	:70a:	Narrative	C, D or E	:4!c	1.8.16	67
M	:16S:	End of Block	SETPRTY			68
End of Subsequence E1 Settlement Parties						
Optional Repetitive Subsequence E2 Cash Parties (not considered)						
End of Subsequence E2 Cash Parties (not considered)						
Mandatory Repetitive Subsequence E3 Amount (not considered)						
M	:16S:	End of Block	SETDET			81
End of Sequence E Settlement Details						
Optional Repetitive Sequence F Other Parties (not considered)						

3.1.2. Example of a Receive Free Confirmation of internal transfer within a Depository/Custodian

This is an example of a Receive Free Confirmation as a result of internal transfer into an account with a Depository/Custodian from another account with the same Depository/Custodian (the instruction is described in Example 1 section 2.1.2).

Confirmation number – 040730/CONF544-1.

Number of the instruction to be confirmed – KL00412/A-861.

Effective settlement date – the 23rd of September 2004.

Trade date – the 16th of September 2004.

Financial Instrument is defined by the following details:

- ISIN RU0008959655
- Narrative description of RAO EeS securities (Russia) with transliteration indicator – ‘RAOEeS.

Quantity of settled financial instrument – 1500 units.

Safekeeping account that was credited – 1111.

Type of Settlement Transaction – settlement of a trade, indicator SETR//TRAD.

Place of Settlement is the institution that services the accounts to which the securities have been credited/debited, BIC DEPORUMM.

Name of the owner of the account from which the securities have been moved – ABC Broker, account number 2222, BIC BROKRUMM.

Transaction basis is the contract of purchase and sale №45HII-1 dated the 16th of September 2004. Russian letters in the contract number should be transliterated.

Message flow.

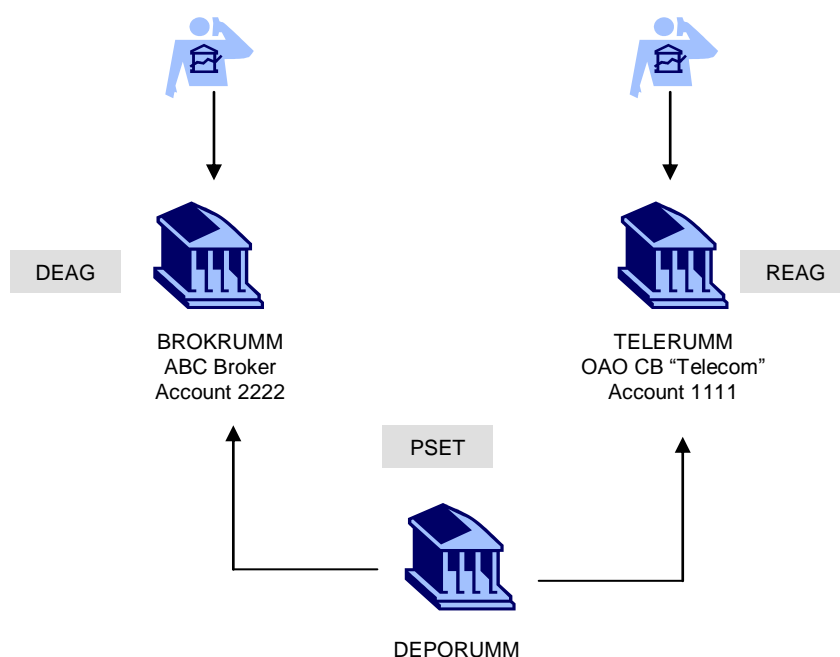

Sender of MT544 DEPORUMM
Receiver of MT544 TELERUMM

Message structure.

:16R:GENL
:20C::SEME//040730/CONF544-1
:23G:NEWM
:16R:LINK
:20C::RELA//KL00412/A-861
:16S:LINK
:16S:GENL
:16R:TRADDET
:98A::ESET//20040923
:98A::TRAD//20040916
:35B:ISIN RU0008959655
'RAO EeS
:16S:TRADDET
:16R:FIAC
:36B::ESTT//UNIT/1500,
:97A::SAFE//1111
:16S:FIAC
:16R:SETDET
:22F::SETR//TRAD
:16R:SETPRTY
:95P::PSET//DEPORUMM
:16S:SETPRTY
:16R:SETPRTY
:95P::DEAG//BROKRUMM
:97A::SAFE//2222
:70E::DECL//TYPE/BYSA/NUMB/45'NP-1'/DATE/20040916
:16S:SETPRTY
:16S:SETDET

3.1.3. Example of a Receive Free Confirmation from an account serviced by a third party

This is an example of a Receive Free Confirmation of into an account with a Depository/Custodian from an account in the Registrar (the instruction is described in Example 1 section 2.1.3).

Confirmation number – 040730/CONF544-2.

Number of the instruction to be confirmed – ANF-34/DF.

Posting Date of an entry in the registry (effective settlement date) – the 22nd of September 2004.

Settlement Date indicated in the Client's instruction – the 23rd of September 2004.

Financial Instrument is defined by the following details:

National state registration number 2-07-03-00345-A

Corporate identifier 54327RT assigned by the Depository that services the Client's account

Narrative description of ordinary shares of the third issue OAO "X-neft" with transliteration indicator – 'OAO "IKS-NEFTX" AO3.

Quantity of settled financial instrument – 8000 units.

Safekeeping account to which the securities have been credited – 1111NM, account of OAO CB "Telecom".

Type of Settlement Transaction – securities movement without Change of Beneficial Ownership, indicator SETR//OWNE.

Place of Settlement is the institution which is the Register Holder, Place of Settlement code - REGISTRAR.

Name of the owner of the account in the registry from which the securities are moved – ZAO Company "Alliance", its account number is not indicated in this example.

Type of the account with the Registrar to be debited – nominal holder's account.

Transaction basis is the depository contract №25 dated the 14th of September 2004.

Message flow.

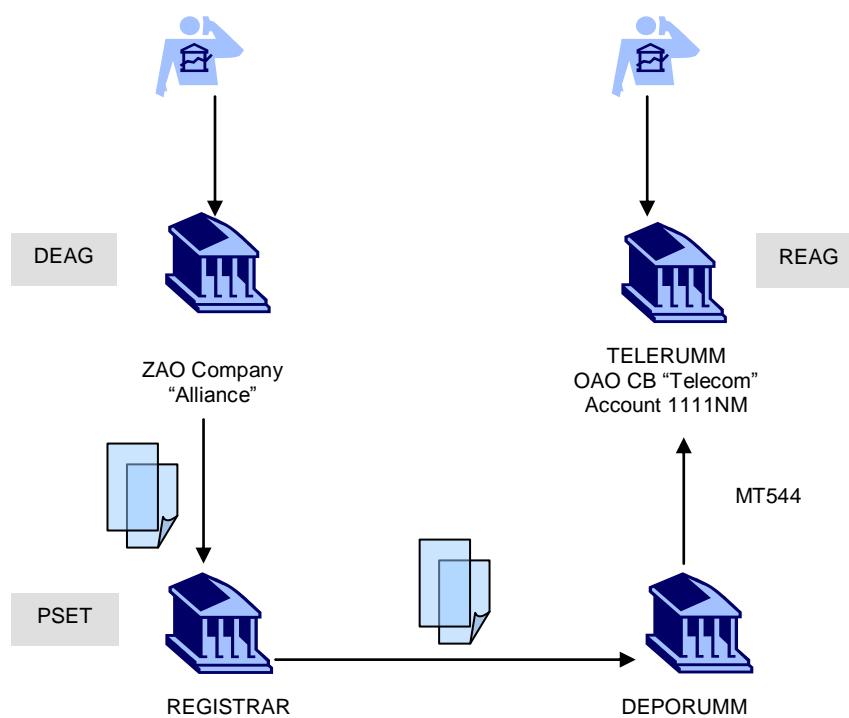

Sender of MT544 DEPORUMM

Receiver of MT544 TELERUMM

Message structure.

:16R:GENL

:20C::SEME//040730/CONF544-2

:23G:NEWM

:16R:LINK

:20C::RELA//ANF-34/DF
:16S:LINK
:16S:GENL
:16R:TRADDET
:98A::ESET//20040922
:98A::SETT//20040923
:98A::TRAD//20040921
:35B://XX/CORP/DEPO/54327RT
/RU/2-07-03-00345-A
'OAO 'IKS-NEFTX' AO3
:16S:TRADDET
:16R:FIAC
:36B::ESTT//UNIT/8000,
:97A::SAFE//1111NM
:16S:FIAC
:16R:SETDET
:22F::SETR//OWNE
:16R:SETPRTY
:95Q::PSET//REGISTRAR
:16S:SETPRTY
:16R:SETPRTY
:95Q::DEAG//'ZAO KOMPANIa'' ALLIANCE''
:70E::DECL//TYPE/OTHR/DEPA/NUMB/25/DATE/20040914
TYPE/BYSA/NUMB/RT12345/DATE/20040521
:70D::PART//OWNT/NOMI
:16S:SETPRTY
:16S:SETDET

3.2. MT545 RECEIVE AGAINST PAYMENT CONFIRMATION

This message is sent by an account servicer (account servicing institution) to an account owner or its designated agent. This message is used to:

- confirm the receipt of financial instruments against payment, physically or by book-entry, from a specified party (the function of the message is NEWM)
- cancel a confirmation of a receipt against payment previously sent by the account servicer (the function of the message is CANC)
- reverse a confirmation of a receipt against payment previously sent by the account servicer (the function of the message is RVSL).

The message is also used to pre-confirm settlement or to confirm a partial settlement of a receipt of financial instruments against payment.

3.2.1. Format Specifications

Status	Tag	Detailed Field Name	Content/Options	Qualifier	№ RUS	№ SWIFT User Handbook
Mandatory Sequence A General Information						
M	:16R	Start of Block	GENL			1
M	:20C:	Sender's Message Reference	:4!c//16x	SEME	1.8.6	2
M	:23G:	Function of the Message	4!c[4!c]		1.8.9	3
O	:98a:	Preparation Date/Time	A or C	PREP	1.8.23	4
Optional Repetitive Subsequence A1 Linkages						
M	:16R:	Start of Block	LINK			6
M	:20C:	Linked Message Reference	:4!c//16x	RELA	1.8.7	9
M	16S:	End of Block	LINK			10
End of Subsequence A1 Linkages						
M	:16S:	End of Block	GENL			11
End of Sequence A General Information						
Mandatory Sequence B Trade Details						
M	:16R:	Start of Block	TRADDET			12
M	:98a:	Effective Settlement Date/Time	A,B or C	ESET	1.8.23	14
O	:98a:	Settlement Date/Time	A,B or C	SETT	1.8.23	14

O	:98a:	Trade Date/Time	A,B or C	TRAD	1.8.23	14
M	:35B:	Identification of the Financial Instrument	[ISIN1!e12!c][4*35x]		1.8.13	17
Optional Subsequence B1 Financial Instrument Attributes (not considered)						
M	:16S:	End of Block	TRADDET			34
End of Sequence B Settlement Transaction Details						
Mandatory Repetitive Sequence C Financial Instrument/Account						
M	:16R:	Start of Block	FIAC			35
M	:36B:	Quantity of the financial instrument	:4!c//4!c/15d	ESTT	1.8.14	36
O	:95a:	Party/Account Owner	P or R	ACOW	1.8.21	39
M	:97a:	Safekeeping Account	A or B	SAFE	1.8.22	40
M	:16S:	End of Block	FIAC			42
End of Sequence C Financial Instrument/Account						
Optional Sequence D Two Leg Transaction Details (not considered)						
Mandatory Sequence E Settlement Details						
M	:16R:	Start of Block	SETDET			60
M	:22F:	Indicator	:4!c/[8c]/4!c	SETR	1.8.8	61
Mandatory Repetitive Subsequence E1 Settlement Parties						
M	:16R:	Start of Block	SETPRTY			62
M	:95a:	Party/Place of Settlement	C, P or Q	PSET	1.8.21	63
M	:95a:	Party/Deliver ing agent	P, Q or R	DEAG	1.8.21	63
O	:95a:	Party/Seller	P, Q or R	SELL	1.8.21	63
O	:95a:	Party/Buyer	P, Q or R	BUYR	1.8.21	63
O	:97a:	Safekeeping Account	A or B	SAFE	1.8.22	64
O	:70a:	Narrative	C, D or E	:4!c	1.8.16	67
M	:16S:	End of Block	SETPRTY			68
End of Subsequence E1 Settlement Parties						
Optional Repetitive Subsequence E2 Cash Parties						
M	:16R:	Start of Block	CSHPRTY			69
M	:95a:	Party	P, Q or R	:4!c	1.8.21	70
O	:97a:	Account/Cas h account	A or E	CASH	1.8.22	71
M	:16S:	End of Block	CSHPRTY			74
End of Subsequence E2 Cash Parties						
Mandatory Repetitive Subsequence E3 Amount						
M	:16R:	Start of Block	AMT			75

M	:19A:	Amount	:4!c//[N]3!a15	ESTT	1.8.5	77
			d			
M	:16S:	End of Block	AMT			80
End of Subsequence E3 Amount						
M	:16S:	End of Block	SETDET			81
End of Sequence E Settlement Details						
Optional Repetitive Sequence F Other Parties (not considered)						

3.2.2. Example of a Receive Against Payment Confirmation within a Depository/Custodian

This is an example of a Receive Against Payment Confirmation as a result of internal transfer into an account at a Depository/Custodian from another account at the same Depository/Custodian (the instruction is described in section 2.2.2).

Confirmation number – 040730/CONF545-1.

Number of the instruction to be confirmed – TEN004-346A.

Effective settlement date – the 23rd of September 2004.

Trade date – the 16th of September 2004.

Financial Instrument is defined by the following details:

- ISIN RU0009024277
- Narrative description of NK Lukoil securities with transliteration indicator – ‘NK LUKOIL.

The rules of financial instrument’s indication are defined in section 1.8.13 of this document.

Quantity of settled financial instrument - 4000 units.

Safekeeping account to which the securities have been credited – 1111NM, cash account number that has been debited – 001USB.

Type of Settlement Transaction – settlement of a trade, indicator SETR//TRAD.

Place of Settlement is the institution that services the safekeeping accounts, BIC DEPORUMM.

Name of the owner of the account from which the securities are moved – ABC Broker, account number - 2222, BIC BROKRUMM.

Transaction basis is the contract of purchase and sale №675/003 dated the 16th of September 2004.

Bank servicing the account of the Receiver of the cash amount is USBank, BIC BANKRUMM.

Receiver’s cash account number with this bank – 002USB.

Total cash amount paid for the securities – 100000 US dollars.

Message flow.

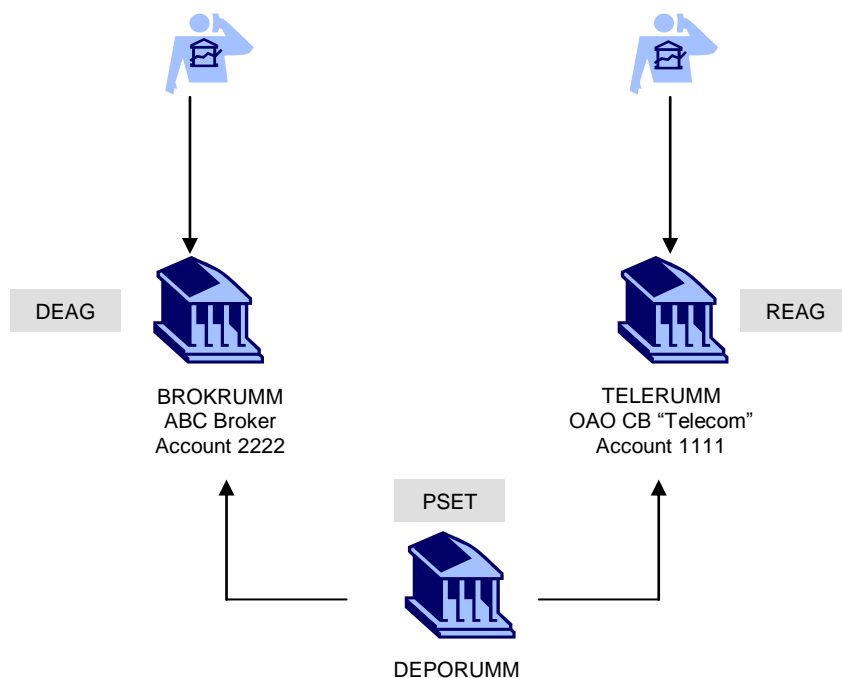

Sender of MT545 DEPORUMM

Receiver of MT545 TELERUMM

Message structure.

```
:16R:GENL
:20C::SEME//040730/CONF545-1
:23G:NEWM
:16R:LINK
:20C::RELA//TEN004-346A
:16S:LINK
:16S:GENL
:16R:TRADDET
:98A::ESET//20040923
:98A::TRAD//20040916
:35B:ISIN RU0009024277
NK LUKOIL
:16S:TRADDET
:16R:FIAC
:36B::ESTT//UNIT/4000,
:97A::SAFE//1111NM
:97A::CASH//001USB
:16S:FIAC
:16R:SETDET
:22F::SETR//TRAD
:16R:SETPRTY
:95P::PSET//DEPORUMM
:16S:SETPRTY
:16R:SETPRTY
:95P::DEAG//BROKRUMM
```

:97A::SAFE//2222
:70E::DECL//TYPE/BYSA/NUMB/675/003/DATE/20040916
:16S:SETPRTY
:16R:CSHPRTY
:95P::ACCW//BANKRUMM
:16S:CSHPRTY
:16R:CSHPRTY
:95P::BENM//BROKRUMM
:97A::CASH//002USB
:16R:AMT
:19A::ESTT//USD100000,
:16S:AMT
:16S:SETDET

3.3. MT546 DELIVER FREE CONFIRMATION

This message is sent by an account servicer (account servicing institution) to an account owner or its designated agent. This message is used to:

- confirm the delivery of financial instruments free of payment, physically or by book-entry, from a specified party (the function of the message is NEWM)
- cancel a confirmation of a delivery free of payment previously sent by the account servicer (the function of the message is CANC)
- reverse a confirmation of a delivery free of payment previously sent by the account servicer (the function of the message is RVSL).

The message is also used to pre-confirm settlement or to confirm a partial settlement of a delivery of financial instruments free of payment.

3.3.1. Format Specifications

Status	Tag	Detailed Field Name	Content/Options	Qualifier	№ RUS	№ SWIFT User Handbook
Mandatory Sequence A General Information						
M	:16R	Start of Block	GENL			1
M	:20C:	Sender's Message Reference	:4!c//16x	SEME	1.8.6	2
M	:23G:	Function of the Message	4!c[4!c]		1.8.9	3
O	:98a:	Preparation Date/Time	A or C	PREP	1.8.23	4
Optional Repetitive Subsequence A1 Linkages						
M	:16R:	Start of Block	LINK			6
M	:20C:	Linked Message Reference	:4!c//16x	RELA	1.8.7	9
M	16S:	End of Block	LINK			10
End of Subsequence A1 Linkages						
M	:16S:	End of Block	GENL			11
End of Sequence A General Information						
Mandatory Sequence B Trade Details						
M	:16R:	Start of Block	TRADDET			12
M	:98a:	Effective Settlement Date/Time	A,B or C	ESET	1.8.23	14
O	:98a:	Settlement Date/Time	A,B or C	SETT	1.8.23	14
O	:98a:	Trade Date/Time	A,B or C	TRAD	1.8.23	14

M	:35B:	Identification of the Financial Instrument	[ISIN1!e12!c][4*35x]		1.8.13	17
Optional Subsequence B1 Financial Instrument Attributes (not considered)						
M	:16S:	End of Block	TRADDET			34
End of Sequence B Settlement Transaction Details						
Mandatory Repetitive Sequence C Financial Instrument/Account						
M	:16R:	Start of Block	FIAC			35
M	:36B:	Quantity of the financial instrument	:4!c//4!c/15d	ESTT	1.8.14	36
O	:95a:	Party/Account Owner	P or R	ACOW	1.8.21	39
M	:97a:	Safekeeping Account	A or B	SAFE	1.8.22	40
M	:16S:	End of Block	FIAC			42
End of Sequence C Financial Instrument/Account						
Optional Sequence D Two Leg Transaction Details (not considered)						
Mandatory Sequence E Settlement Details						
M	:16R:	Start of Block	SETDET			60
M	:22F:	Indicator	:4!c/[8c]/4!c	SETR	1.8.8	61
Mandatory Repetitive Subsequence E1 Settlement Parties						
M	:16R:	Start of Block	SETPRTY			62
M	:96a:	Party/Place of Settlement	C, P or Q	PSET	1.8.21	63
M	:95a:	Party/Receiving Agent	P, Q or R	REAG	1.8.21	63
	:95a:	Party/Seller	P, Q or R	SELL	1.8.21	63
	:95a:	Party/Buyer	P, Q or R	BUYR	1.8.21	63
O	:97a:	Safekeeping Account	A or B	SAFE	1.8.22	64
O	:70a:	Narrative	E,C or D		1.8.16	67
M	:16S:	End of Block	SETPRTY			68
End of Subsequence E1 Settlement Parties						
Optional Repetitive Subsequence E2 Cash Parties (not considered)						
Mandatory Repetitive Subsequence E3 Amount (not considered)						
M	:16S:	End of Block	SETDET			68
End of Sequence E Settlement Details						
Optional Repetitive Sequence F Other Parties (not considered)						

3.3.2. Example of a Deliver Free Confirmation of transfer from account with a Depository/Custodian

This is an example of a Deliver Free Confirmation as a result of transfer from an account with a Depository/Custodian, while the account to which the securities are credited is serviced by the same Depository/Custodian (the instruction is described in section 2.3.2).

Confirmation number – 040730/CONF546-1.

Number of the instruction to be confirmed – 234521/45NP-1.

Effective settlement date – the 23rd of September 2004.

Trade date – the 16th of September 2004.

Financial Instrument is defined by the following details:

- ISIN RU0008959655
- Narrative description of RAO EeS securities (Russia) with transliteration indicator – ‘RAO EeS.

Quantity of settled financial instrument – 1500 units.

Safekeeping account from which the securities have been debited – 2222.

Type of Settlement Transaction – settlement of a trade, indicator SETR//TRAD.

Place of Settlement is the institution that services the safekeeping accounts to be debited/credited with the securities, BIC DEPORUMM.

Name of the owner of the account to which the securities have been credited – OAO CB “Telecom”, account number – 1111, BIC TELERUMM.

Transaction basis is the contract of purchase and sale №45HII-1 dated the 16th of September 2004. Russian letters in the contract number should be transliterated.

Message flow.

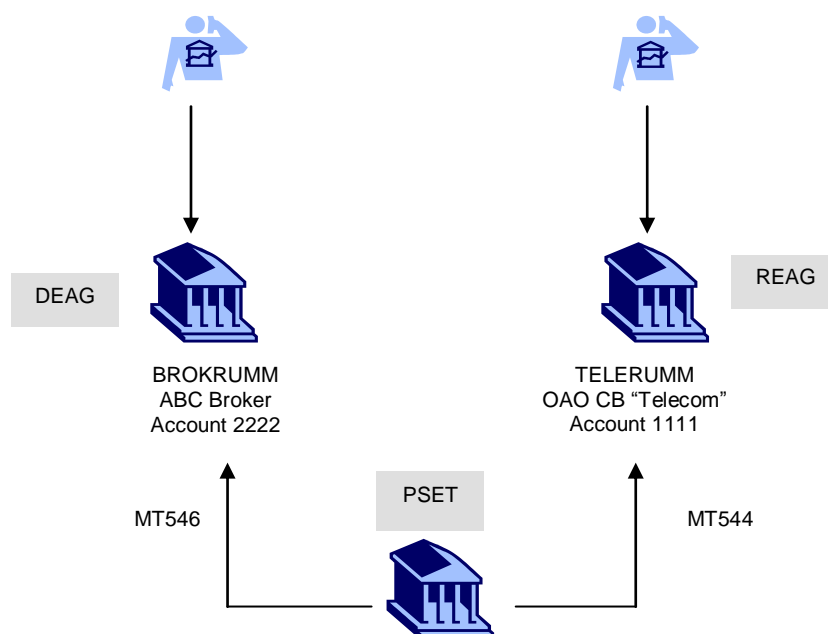

Sender of MT546 DEPORUMM

Receiver of MT546 BROKRUMM

Message structure.

:16R:GENL

:20C::SEME//040730/CONF546-1
 :23G:NEWM
 :16R:LINK
 :20C::RELA//234521/45NP-1
 :16S:LINK
 :16S:GENL
 :16R:TRADDET
 :98A::ESET//20040923
 :98A::TRAD//20040916
 :35B:ISIN RU0008959655
 'RAO EeS
 :16S:TRADDET
 :16R:FIAC
 :36B::ESTT//UNIT/1500,
 :97A::SAFE//2222
 :16S:FIAC
 :16R:SETDET
 :22F::SETR//TRAD
 :16R:SETPRTY
 :95P::PSET//DEPORUMM
 :16S:SETPRTY
 :16R:SETPRTY
 :95P::REAG//TELERUMM
 :97A::SAFE//1111
 :70E::DECL//TYPE/BYSA/NUMB/45'NP-1'/DATE/20040916
 :16S:SETPRTY
 :16S:SETDET

3.3.3. Example of a Deliver Free Confirmation of transfer to an account serviced by an external party

This is an example of a Deliver Free Confirmation of transfer from an account with a Depository/Custodian involving Change of Beneficial Ownership. Securities are delivered to an institution's account opened at the Registrar (the instruction is described in Example 2 section 2.3.3).

Confirmation number – 040730/CONF546-2.

Number of the instruction to be confirmed – SAMP542/OWN.

Date of making an entry in the registry (effective settlement date) – the 20th of September 2004.

Date of book-entry in the Depository/Custodian – the 23rd of September 2004.

Financial Instrument is defined by the following details:

- ISIN RU0009034268
- National state registration number 1-01-00029-A
- Narrative description of OAO "GAZ" securities with transliteration indicator – 'OAO "GAZ"'.

Quantity of settled financial instrument – 3000 units.

Safekeeping account with the Depository/Custodian which has been debited – 1111NM.

Type of Settlement Transaction – securities movement with Change of Beneficial Ownership, indicator SETR//TRAD.

Place of Settlement is the institution which is the Register Holder, Place of Settlement code - REGISTRAR.

Name of the owner of the account in the registry to which the securities have been delivered – OAO “Telestar”, its account number is not indicated in this example.

Transaction basis is:

the depository contract №134 dated the 1st of February 2002

the contract of purchase and sale №RT12345 dated the 11th of September 2004.

The confirmation does not contain any details of the party to the name of which the securities are re-registered.

Type of the account with the Registrar to be credited – owner’s account.

Message flow.

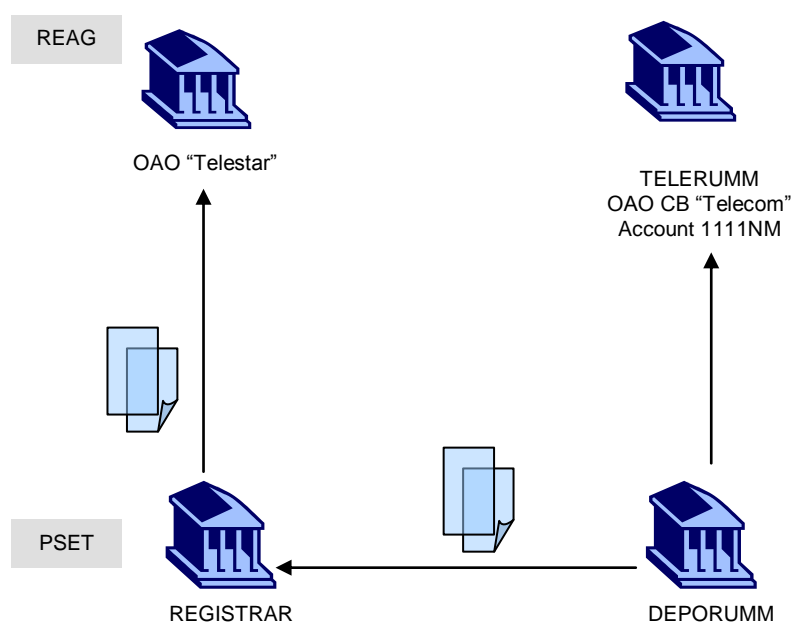

Sender of MT546 DEPORUMM

Receiver of MT546 TELERUMM

Message structure.

:16R:GENL
:20C::SEME//040730/CONF546-2
:23G:NEWM
:16R:LINK
:20C::RELA//SAMP542/OWN
:16S:LINK
:16S:GENL
:16R:TRADDET
:98A::ESET//20040920

:98A::SETT//20040923
:35B::ISIN RU0009034268
/RU/1-01-00029-A
'OAO "GAZ"
:16S:TRADDET
:16R:FIAC
:36B::ESTT//UNIT/3000,
:97A::SAFE//1111NM
:16S:FIAC
:16R:SETDET
:22F::SETR//TRAD
:16R:SETPRTY
:95Q::PSET//REGISTRAR
:16S:SETPRTY
:16R:SETPRTY
:95Q::REAG//"OAO "TELESTAR"
:70E::DECL//TYPE/DEPA/NUMB/134/DATE/20020201
/TYPE/BYSA/NUMB/RT12345/DATE/20040911
:70D::PART//OWNT/OWNE
:16S:SETPRTY
:16S:SETDET

3.4. MT547 DELIVER AGAINST PAYMENT CONFIRMATION

This message is sent by an account servicer (account servicing institution) to an account owner or its designated agent. This message is used to:

- confirm the delivery of financial instruments against payment, physically or by book-entry, from a specified party (the function of the message is NEWM)
- cancel a confirmation of a delivery against payment previously sent by the account servicer (the function of the message is CANC)
- reverse a confirmation of a delivery against payment previously sent by the account servicer (the function of the message is RVSL).

The message is also used to pre-confirm settlement or to confirm a partial settlement of a delivery of financial instruments against payment.

3.4.1. Format Specifications

Status	Tag	Detailed Field Name	Content/Options	Qualifier	№ RUS	№ SWIFT User Handbook
Mandatory Sequence A General Information						
M	:16R:	Start of Block	GENL			1
M	:20C:	Sender's Message Reference	:4!c//16x	SEME	1.8.6	2
M	:23G:	Function of the Message	4!c[/4!c]		1.8.9	3
O	:98a:	Preparation Date/Time	A or C	PREP	1.8.23	4
Optional Repetitive Subsequence A1 Linkages						
M	:16R:	Start of Block	LINK			6
M	:20C:	Linked Message Reference	:4!c//16x	RELA	1.8.7	9
M	16S:	End of Block	LINK			10
End of Subsequence A1 Linkages						
M	:16S:	End of Block	GENL			11
End of Sequence A General Information						
Mandatory Sequence B Trade Details						
M	:16R:	Start of Block	TRADDET			12
M	:98a:	Effective Settlement Date/Time	A,B or C	ESET	1.8.23	14
O	:98a:	Settlement Date/Time	A,B or C	SETT	1.8.23	14

O	:98a:	Trade Date/Time	A,B or C	TRAD	1.8.23	14
M	:35B:	Identificatio n of the Financial Instrument	[ISIN!e12!c][4*35x]		1.8.13	17
Optional Subsequence B1 Financial Instrument Attributes (not considered)						
M	:16S:	End of Block	TRADDET			34
End of Sequence B Settlement Transaction Details						
Mandatory Repetitive Sequence C Financial Instrument/Account						
M	:16R:	Start of Block	FIAC			35
M	:36B:	Quantity of the financial instrument	:4!c//4!c/15d	SETT	1.8.14	36
O	:95a:	Party/Accou nt Owner	P or R	ACOW	1.8.21	39
M	:97a:	Safekeeping Account	A or B	SAFE	1.8.22	40
M	:16S:	End of Block	FIAC			42
End of Sequence C Financial Instrument/Account						
Optional Sequence D Two Leg Transaction Details (not considered)						
Mandatory Sequence E Settlement Details						
M	:16R:	Start of Block	SETDET			60
M	:22F:	Indicator	:4!c/[8c]/4!c	SETR	1.8.8	61
Mandatory Repetitive Subsequence E1 Settlement Parties						
M	:16R:	Start of Block	SETPRTY			63
M	:95a:	Party/Place of Settlement	C, P or Q	PSET	1.8.21	63
M	:95a:	Party/Recei ving agent	P, Q or R	REAG	1.8.21	63
O	:95a:	Party/Seller	P, Q or R	SELL	1.8.21	63
O	:95a:	Party/Buyer	P, Q or R	BUYR	1.8.21	63
O	:97a:	Safekeeping Account	A or B	SAFE	1.8.22	64
O	:70a:	Narrative	C, D or E	:4!c	1.8.16	67
M	:16S:	End of Block	SETPRTY			68
End of Subsequence E1 Settlement Parties						
Optional Repetitive Subsequence E2 Cash Parties						
M	:16R:	Start of Block	CSHPRTY			69
M	:95a:	Party	P, Q or R	:4!c	1.8.21	70
O	:97a:	Account/Ca sh account	A or E	CASH	1.8.22	71

M	:16S:	End of Block	CSHPRTY			74
End of Subsequence E2 Cash Parties						
Mandatory Repetitive Subsequence E3 Amount						
M	:16R:	Start of Block	AMT			75
M	:19A:	Amount	:4!c//[N]3!a15 d	ESTT	1.8.5	77
M	:16S:	End of Block	AMT			80
End of Subsequence E3 Amount						
M	:16S:	End of Block	SETDET			81
End of Sequence E Settlement Details						
Optional Repetitive Sequence F Other Parties (not considered)						

3.4.2. Example of a Deliver Against Payment Confirmation of transfer from account within a Depository/Custodian

This is an example of a Deliver Against Payment Confirmation of transfer from an account with a Depository/Custodian, while the account to which the securities are credited is serviced by the same Depository/Custodian (the instruction is described in section 2.4.2).

Confirmation number – 040730/CONF547-1.

Number of the instruction to be confirmed – DVP040602/543.

Effective settlement date – the 23rd of September 2004.

Trade date – the 16th of September 2004.

Financial Instrument is defined by the following details:

- ISIN RU0009024277
- Narrative description of NK Lukoil securities with transliteration indicator – ‘NK LUKOIL.

The rules of financial instrument’s indication are defined in section 1.8.13 of this document.

Quantity of settled financial instrument – 4000 units.

Safekeeping account from which the securities have been debited – 2222.

Type of Settlement Transaction – settlement of a trade, indicator SETR//TRAD.

Place of Settlement is the institution that services the safekeeping accounts to be debited/credited with the securities, BIC DEPORUMM.

Name of the owner of the account which has been credited with the securities – OAO CB “Telecom”, account number – 1111NM, BIC TELERUMM.

Transaction basis is the contract of purchase and sale №675/003 dated the 16th of September 2004.

Bank servicing the account of the Receiver of the cash amount is USBank, BIC BANKRUMM.

Receiver's cash account number with this bank – 002USB.

Total cash amount received for the securities – 100000 US dollars.

Message flow.

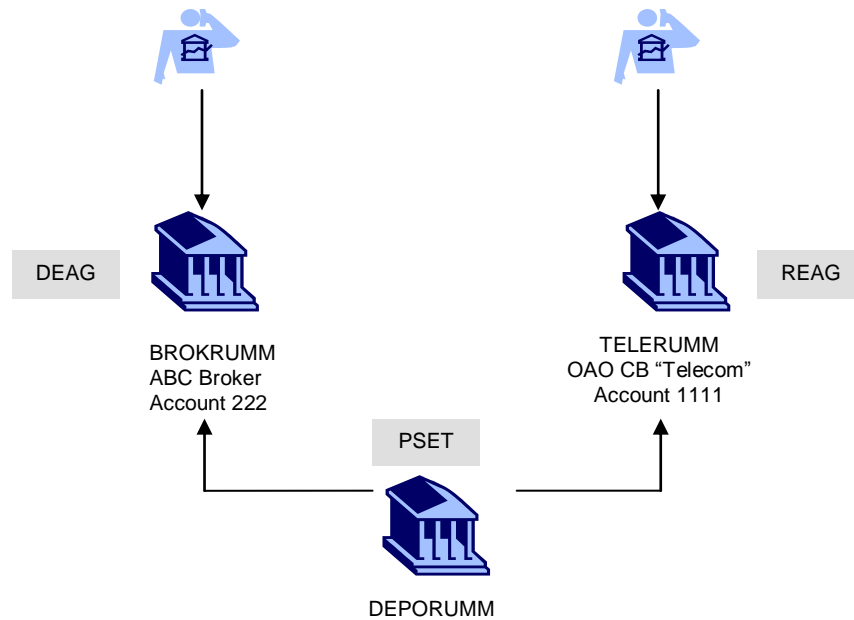

Sender of MT547 DEPORUMM

Receiver of MT547 BROKRUMM

Message structure.

```
:16R:GENL
:20C::SEME//040730/CONF547-1
:23G:NEWM
:16R:LINK
:20C::RELA//DVP040602/543
:16S:LINK
:16S:GENL
:16R:TRADDET
:98A::ESET//20040923
:98A::TRAD//20040916
:35B:ISIN RU0009024277
NK LUKOIL
:16S:TRADDET
:16R:FIAC
:36B::ESTT//UNIT/4000,
:97A::SAFE//2222
:16S:FIAC
:16R:SETDET
:22F::SETR//TRAD
:16R:SETPRTY
:95P::PSET//DEPORUMM
:16S:SETPRTY
:16R:SETPRTY
```

:95P::REAG//TELERUMM
:97A::SAFE//1111NM
:70E::DECL//TYPE/BYSA/NUMB/675/003/DATE/20040916
:16S:SETPRTY
:16R:CSHPRTY
:95P::ACCW//BANKRUMM
:16S:CSHPRTY
:16R:CSHPRTY
:95P::BENM//BROKRUMM
:97A::CASH//002USB
:16S:CSHPRTY
:16R:AMT
:19A::ESTT//USD100000,
:16S:AMT
:16S:SETDET

3.5. MT548 SETTLEMENT STATUS AND PROCESSING ADVICE

This message is sent by an account servicer (account servicing institution) to an account owner. This message can be used to:

- to confirm the acceptance of an instruction for further processing by the Depository/Custodian or to advise the rejection of the instruction
- to advise the current status of a settlement instruction in the account servicing institution (matching status, settlement status) or to advise the pending/failing of matching, settlement, cancellation etc. with indication of reason if possible.

3.5.1. Format Specifications

Status	Tag	Detailed Field Name	Content/Options	Qualifier	N ^o RUS	N ^o SWIFT User Handbook
Mandatory Sequence A General Information						
M	:16R	Start of Block	GENL			1
M	:20C:	Sender's Message Reference	:4!c//16x	SEME	1.8.6	2
M	:23G:	Function of the Message	4!c/[4!c]		1.8.9	3
O	:98a:	Preparation Date/Time	A,C or E	PREP	1.8.23	4
Optional Repetitive Subsequence A1 Linkages						
M	:16R:	Start of Block	LINK			5
M	:20C:	Linked Message Reference	:4!c//16x	RELA	1.8.7	7
M	:16S:	End of Block	LINK			8
End of Subsequence A1 Linkages						
Mandatory Repetitive Subsequence A2 Status						
M	:16R:	Start of Block	STAT			9
M	:25D:	Status	:4!c/[8c]/4!c		1.8.11	10
Optional Repetitive Subsequence A2a Reason						
M	:16R:	Start of Block	REAS			11
M	:24B:	Reason	:4!c/[8c]/4!c		1.8.10	12
O	:70D:	Reason Narrative	:4!c//6*35x	REAS	1.8.16	13
M	:16S:	End of Block	REAS			14
End of Subsequence A2a Reason						
M	:16S:	End of Block	STAT			15
End of Subsequence A2 Status						

M	:16S:	End of Block	GENL			16
End of Sequence A General Information						
Mandatory Sequence B Trade Details						
M	:16R:	Start of Block	SETTRAN			17
M	:35B:	Identification of the Financial Instrument	[ISIN1!e12!c][4*35x]		1.8.13	19
M	:36B:	Quantity of the financial instrument	:4!c//4!c/15d	SETT	1.8.14	20
O	:19A:	Amount	:4!c//[N]3!a15d	SETT	1.8.5	21
M	:97a:	Safekeeping Account	A or B	SAFE	1.8.22	23
M	:22F:	Type of Settlement Transaction Indicator	:4!c/[8c]/4!c	SETR	1.8.8	24
M	:22H:	Payment Indicator	:4!c//4!c	PAYM	1.8.8	24
M	:22H:	Receive/Deliver Indicator	:4!c//4!c	REDE	1.8.8	24
O	:98a:	Settlement Date/Time	A,B or C	SETT	1.8.23	25
Optional Subsequence B1 Financial Instrument Attributes						
M	:16R:	Start of Block	SETPRTY			27
M	:95a:	Party/Place of Settlement	P, Q or R	PSET	1.8.21	28
M	:95a:	Party	C, S, P, R or Q	:4!c	1.8.21	28
O	:97a:	Safekeeping Account	A or B	SAFE	1.8.22	29
M	:16S:	End of Block	SETPRTY			31
End of Subsequence B1 Settlement Parties						
M	:16S:	End of Block	SETTRAN			32
End of Sequence B Settlement Transaction Details						
Optional Sequence C Additional Information (not considered)						

3.5.2. Example of MT548 - advice (receipt) of an instruction acceptance for further processing

Example 1.

This is an example of an advice sent by the Depository/Custodian to the account owner institution (OAO CB “Telecom”, BIC TELERUMM) with confirmation of acceptance of its previously sent instruction for further processing in the Depository/Custodian (the instruction is described in Example 1 section 2.1.2).

Number of the instruction to which the advice is related – KL00412/A-861.

Preparation date and time of the advice – the 23rd of September 2004, 12:06:17.

Instruction processing status IPRC – PACK, acknowledged/accepted for further processing.

This advice contains the main details of the settlement instruction: type, safekeeping account number, quantity of securities, expected settlement date, account number and name of the counterparty.

Sender of MT548 DEPORUMM

Receiver of MT548 TELERUMM

Message structure:

:16R:GENL
:20C::SEME//040923/548-00012
:23G:INST
:98C::PREP//20040923120617
:16R:LINK
:13A::LINK//540
:20C::RELA//KL00412/A-861
:16S:LINK
:16R:STAT
:25D::IPRC//PACK
:16S:STAT
:16S:GENL
:16R:SETTRAN
:35B:ISIN RU0008959655
‘RAO EeS
:36B::SETT//UNIT/1500,
:97A::SAFE//1111
:22H::REDE//RECE
:22H::PAYM//FREE
:22F::SETR//TRAD
:98A::SETT//20040923
:16R:SETPRTY
:95P::PSET//DEPORUMM
:16S:SETPRTY
:16R:SETPRTY
:95P::DEAG//BROKRUMM
:97A::SAFE//2222
:16S:SETPRTY
:16S:SETTRAN

3.5.3. Example of MT548 – rejection of an instruction for further processing

Example 1.

This is an example of an advice sent by the Depository/Custodian to the account owner institution (ABC Broker, BIC BROKRUMM) informing that its previously sent instruction has been rejected by the Depository/Custodian (the instruction is described in section 2.3.2).

Rejection reason – unrecognized securities identification.

The Depository/Custodian may indicate additional text description of the rejection reason if there is an appropriate bilateral agreement.

Number of the instruction to which the advice is related – 234521/45NP-1.

Preparation date and time of the advice – the 23rd of September 2004, 11:56:34.

Instruction processing status IPRC – REJT, rejected for further processing.

Rejection reason code – DSEC, unrecognized or invalid financial instrument identification (the instruction contains incorrect ISIN).

This advice contains the main details of the settlement instruction: type, safekeeping account number, quantity of securities, expected settlement date, account number and name of the counterparty.

Sender of MT548 DEPORUMM

Receiver of MT548 BROKRUMM

Message structure:

```
:16R:GENL
:20C::SEME//040423/548-0004
:23G:INST
:98C::PREP//20040923115634
:16R:LINK
:13A::LINK//542
:20C::RELA//234521/45NP-1
:16S:LINK
:16R:STAT
:25D::IPRC//REJT
:16R:REAS
:24B::REJT//DSEC
:70D::REAS//Unrecognized or invalid financial instrument identification
:16S:REAS
:16S:STAT
:16S:GENL
:16R:SETTRAN
:35B:ISIN RU0098959655
  'RAO EeS
:36B::SETT//UNIT/1500,
:97A::SAFE//2222
:22H::REDE//DELI
:22H::PAYM//FREE
:22F::SETR//TRAD
```

:98A::SETT//20040923
:16R:SETPRTY
:95P::PSET//DEPORUMM
:16S:SETPRTY
:16R:SETPRTY
:95P::REAG//TELERUMM
:97A::SAFE//1111
:16S:SETPRTY
:16S:SETTRAN

3.5.4. Examples of advices of the current matching/ settlement status of an instruction in the Depository/Custodian

Example 1.

This is an example of an advice sent by the Depository/Custodian to the account owner institution (OAO CB “Telecom”, BIC TELERUMM) informing that its previously sent instruction has been matched (the instruction is described in Example 1 section 2.1.2).

Number of the instruction to which the advice is related – KL00412/A-861.

Preparation date and time of the advice – the 23rd of September 2004, 14:01:13.

Matching status MTCH – MACH, the instruction has been matched.

This advice contains the main details of the settlement instruction: type, safekeeping account number, quantity of securities, expected settlement date, account number and name of the counterparty.

Sender of MT548 DEPORUMM
Receiver of MT548 TELERUMM

Message structure:

:16R:GENL
:20C::SEME//040923/548-00089
:23G:INST
:98C::PREP//20040923140113
:16R:LINK
:13A::LINK//540
:20C::RELA//KL00412/A-861
:16S:LINK
:16R:STAT
:25D::MTCH//MACH
:16S:STAT
:16S:GENL
:16R:SETTRAN
:35B:ISIN RU0008959655
RAO EeS
:36B::SETT//UNIT/1500,
:97A::SAFE//1111
:22H::REDE//RECE
:22H::PAYM//FREE
:22F::SETR//TRAD

:98A::SETT//20040923
:16R:SETPRTY
:95P::PSET//DEPORUMM
:16S:SETPRTY
:16R:SETPRTY
:95P::DEAG//BROKRUMM
:97A::SAFE//2222
:16S:SETPRTY
:16S:SETTRAN

Example 2.

This is an example of an advice sent by the Depository/Custodian to the account owner institution (OAO CB “Telecom”, BIC TELERUMM) informing that its previously sent instruction has not been matched (the instruction is described in section 2.2.2).

Number of the instruction to which the advice is related – TEN004-346A.

Preparation date and time of the advice – the 23rd of September 2004, 15:05:32.

Matching status MTCH – NMAT, the instruction has not been matched.

Reason code – DQUA, quantity of the securities does not match with the quantity in the counterparty’s instruction.

This advice contains the main details of the settlement instruction: type, safekeeping account number, quantity of securities, settlement amount, expected settlement date, account number and name of the counterparty.

Sender of MT548 DEPORUMM

Receiver of MT548 TELERUMM

Message structure:

:16R:GENL
:20C::SEME//040923/548-00150
:23G:INST
:98C::PREP//20040923150532
:16R:LINK
:13A::LINK//541
:20C::RELA//TEN004-346A
:16S:LINK
:16R:STAT
:25D::MTCH//NMAT
:16R:REAS
:24B::NMAT//DQUA
:16S:REAS
:16S:STAT
:16S:GENL
:16R:SETTRAN
:35B:ISIN RU0009024277
‘NK LUKOIL
:36B::SETT//UNIT/4000,
:19A::SETT//USD100000,
:97A::SAFE//1111NM

:22H::REDE//RECE
:22H::PAYM//APMT
:22F::SETR//TRAD
:98A::SETT//20040923
:16R:SETPRTY
:95P::PSET//DEPORUMM
:16S:SETPRTY
:16R:SETPRTY
:95P::DEAG//BROKRUMM
:97A::SAFE//2222
:16S:SETPRTY
:16S:SETTRAN

Example 3.

This is an example of an advice sent by the Depository/Custodian to the account owner institution (ABC Broker, BIC BROKRUMM) informing that settlement of its previously sent instruction is pending.

The instruction is described in section 2.4.2.

Number of the instruction to which the advice is related – DVP040602/543.

Preparation date and time of the advice – the 23rd of September 2004, 16:10:54.

Settlement status SETT – PEND, the instruction settlement is pending.

Reason code – LACK, insufficient deliverable securities in the account.

This advice contains the main details of the settlement instruction: type, safekeeping account number, quantity of securities, settlement amount, expected settlement date, account number and name of the counterparty.

Sender of MT548 DEPORUMM

Receiver of MT548 BROKRUMM

Message structure:

:16R:GENL
:20C::SEME//040923/548-01237
:23G:INST
:98C::PREP//20040923161054
:16R:LINK
:13A::LINK//543
:20C::RELA//DVP040602/543
:16S:LINK
:16R:STAT
:25D::SETT//PEND
:16R:REAS
:24B::PEND//LACK
:16S:REAS
:16S:STAT
:16S:GENL
:16R:SETTRAN
:35B:ISIN RU0009024277
‘NK LUKOIL

:36B::SETT//UNIT/4000,
:19A::SETT//USD100000,
:97A::SAFE//2222
:22H::REDE//DELI
:22H::PAYM//APMT
:22F::SETR//TRAD
:98A::SETT//20040923
:16R::SETPRTY
:95P::PSET//DEPORUMM
:16S::SETPRTY
:16R::SETPRTY
:95P::REAG//TELERUMM
:97A::SAFE//1111NM
:16S::SETPRTY
:16S::SETTRAN

3.6.MT549 REQUEST FOR STATEMENT/STATUS ADVICE

This message is sent by an account owner to an account servicer (account servicing institution). This message can be used to:

- to request statement of holdings in the account serviced by the Depository/Custodian
- to request current intra-system processing status advice of an instruction (or several instructions) in the Depository/Custodian.

3.6.1. Format Specifications

Status	Tag	Detailed Field Name	Content/Options	Qualifier	№ RUS	№ SWIFT User Handbook
Mandatory Sequence A General Information						
M	:16R	Start of Block	GENL			1
M	:20C:	Sender's Message Reference	:4!c//16x	SEME	1.8.6	2
M	:23G:	Function of the Message	4!c/[4!c]		1.8.9	3
O	:98a:	Statement Date/Time	A or C	STAT	1.8.23	4
O	:69a:	Statement Period	A or B	STAT	1.8.15	5
M	:13A:	Requested Message Type	:4!c//3!c	REQU	1.8.3	6
M	:97a:	Account/ Safekeeping account	A or B	SAFE	1.8.22	7
O	:95a:	Party/ Account Owner	P or R	ACOW	1.8.21	8
O	:22F:	Indicator/ Complete/Updates Indicator	:4!c/[8c]/4!c	CODE	1.8.11	9
O	:22F:	Indicator/ Statement Frequency Indicator	:4!c/[8c]/4!c	SFRE	1.8.11	9
O	:22F:	Indicator/ Statement Type	:4!c/[8c]/4!c	STTY	1.8.11	9
O	:22F:	Indicator/ Statement Basis	:4!c/[8c]/4!c	STBA	1.8.11	9

M	:16S:	End of Block	GENL			14
End of Sequence A General Information						
Optional Repetitive Sequence B Statement by Status/Reason and/or by Financial Instrument						
M	:1 6	Start of Block	BYSTAREA			15
	R:					
O	:2 5	Status	:4!c/[8c]/4!c	:4!c	1.8.11	16
	D					
O	:2 4	Reason	:4!c/[8c]/4!c	:4!c	1.8.10	17
	B:					
O	:3 5	Identification of the Financial Instrument	[ISIN1!e12!c][4*35x]		1.8.13	18
	B					
M	:1 6S	End of Block	BYSTAREA			19
	:					
End of Sequence B Statement by Status/Reason and/or by Financial Instrument						
Optional Repetitive Sequence C By Instruction Reference						
M	:1 6	Start of Block	REF			20
	R:					
M	:2 0	Reference	:4!c//16x	:4!c	1.8.7	21
	C					
M	:1 6S	End of Block	REF			22
	:					
End of Sequence C By Instruction Reference						
Optional Sequence D Additional Information						

3.6.2. Request for Statement

Example 1.

This is an example of a Request for Statement sent by the account owner (ABC Broker, BIC BROKRUMM) to the Depository/Custodian to request the statement of holdings (MT535) for the account 2222.

Date on which the statement is requested – the 9th of July 2004.

Sender of MT549 - BROKRUMM

Receiver of MT549 – DEPORUMM

Message structure:

```
:16R:GENL
:20C::SEME//12345/000123
:98A::STAT//20040709
:13A::REQU//535
```

:97A::SAFE//2222
:16S:GENL

Example 2.

This is an example of a Request for Statement sent by the account owner (OAO CB “Telecom”, BIC TELERUMM) to the Depository/Custodian to request the statement of transactions (MT536) for the period from the 14th till the 16th of June 2004 for the account 1111.

Sender of MT549 - TELERUMM
Receiver of MT549 – DEPORUMM

Message structure:

:16R:GENL
:20C::SEME//123
:69A::STAT//20040614/20040616
:13A::REQU//536
:97A::SAFE//1111
:16S:GENL

Example 3.

This is an example of a Request for Statement sent by the account owner (OAO CB “Telecom”, BIC TELERUMM) to the Depository/Custodian to request the statement of holdings (MT535) for the safekeeping account.

The statement is requested for two financial instruments:

RAO EeS (Russia) and NK Lukoil.

Date on which the statement is requested – the 15th of June 2004.

Sender of MT549 - TELERUMM
Receiver of MT549 – DEPORUMM

Message structure:

:16R:GENL
:20C::SEME//123
:98A::STAT//20040615
:13A::REQU//535
:97A::SAFE//1111
:16S:GENL
:16R:BYSTAREA
:35B:ISIN RU0008959655
RAO EeS
:35B:ISIN RU0009024277
NK LUKOIL
:16S:BYSTAREA

Example 4.

This is an example of a Request for Statement sent by the account owner (ABC Broker, BIC BROKRUMM) to the Depository/Custodian to request the statement of pending transactions for the account 2222.

The statement is requested for operations with pending settlement status.

Date on which the statement is requested – the 23rd of September 2004.

Sender of MT549 - BROKRUMM

Receiver of MT549 – DEPORUMM

Message structure:

:16R:GENL
:20C::SEME//12345/000123
:98A::STAT//20040923
:13A::REQU//537
:97A::SAFE//2222
:16S:GENL
:16R:BYSTAREA
:25D::SETT//PEND
:16S:BYSTAREA

3.6.3. Request for Status Advice of an instruction in the Depository/Custodian

Example 1.

This is an example of a Request for Status Advice sent by the account owner (ABC Broker, BIC BROKRUMM) to the Depository/Custodian to request status advice of MT548 instruction.

The instruction was sent to the Depository/Custodian on the 23rd of September 2004 (section 2.4.2), instruction number – DVP040602/543.

Safekeeping account number – 2222.

Sender of MT549 - BROKRUMM

Receiver of MT549 – DEPORUMM

Message structure:

:16R:GENL
:20C::SEME//0001QWER-12
:98A::STAT//20040923
:13A::REQU//548
:97A::SAFE//2222
:16S:GENL
:16R:REF
:20C::PREV//DVP040602/543
:16S:REF

3.6.4. Cancellation of the Request for Status Advice of an instruction in the Depository/Custodian

Example 1.

This is an example of a cancellation of a Request for Status Advice sent by the account owner (ABC Broker, BIC BROKRUMM) to the Depository/Custodian to request cancellation of previously sent Request for Status Advice of an instruction (MT548).

The instruction was sent to the Depository/Custodian on the 23rd of September 2004 (section 2.4.2), instruction number – DVP040602/543.

Number of the Request of Status Advice to be cancelled – 0001 QWER-12 (described in section 3.6.3).

Safekeeping account number – 2222.

Sender of MT549 - BROKRUMM

Receiver of MT549 - DEPORUMM

Message structure:

```
:16R:GENL
:20C::SEME//0001QWER-12
:23G:CANC
:13A::REQU//548
:97A::SAFE//2222
:16R:LINK
:13A::LINK//549
:20C::PREV//0001QWER-12
:16S:LINK
:16S:GENL
:16R:REF
:20C::PREV//DVP040602/543
:16S:REF
```

3.7.MT535 STATEMENT OF HOLDINGS

This message is sent by an account servicer (account servicing institution) to an account owner or its designated agent.

This message is used to report, at a specified moment of time, the quantity and identification of financial instruments which the account servicer holds for the account owner.

The statement is used to reconcile the books of the account owner and the account servicer for the specified safekeeping account or sub-safekeeping account.

This message may also be used to respond to a request for statement/status advice, i.e., the MT 549 Request for Statement/Status Advice and to report that there are no holdings in the account.

3.7.1. Format Specifications

Status	Tag	Detailed Field Name	Content/Options	Qualifier	№ RUS	№ SWIFT User Handbook
Mandatory Sequence A General Information						
M	:16R	Start of Block	GENL			1
M	:28E:	Page Number/Continuation Indicator	5n/4!c		1.8.12	2
O	:13a:	Statement Number	A or J		1.8.3	3
M	:20C:	Sender's Message Reference	:4!c//16x	SEME	1.8.6	4
M	:23G:	Function of the Message	4!c/[4!c]		1.8.9	5
O	:98a:	Preparation Date/Time	A or C	PREP	1.8.23	6
M	:98a:	Statement Date/Time	A or C	STAT	1.8.23	6
O	:22F:	Indicator/Complete/Updates Indicator	:4!c/[8c]/4!c	CODE	1.8.8	7
O	:22F:	Indicator/Statement Frequency Indicator	:4!c/[8c]/4!c	SFRE	1.8.8	7
O	:22F:	Indicator/Statement Type	:4!c/[8c]/4!c	STTY	1.8.8	7
O	:22F:	Indicator/Statement Basis	:4!c/[8c]/4!c	STBA	1.8.8	7

Optional Repetitive Subsequence A1 Linkages (not considered)						
O	:95a:	Party/ Account Owner	P or R	ACOW		12
M	:97a:	Account/ Safekeeping account	A or B	SAFE	1.8.21	13
M	:17B:	Flag/Activity flag	:4!c//1!a	ACTI	1.8.22	14
M	:17B:	Flag/Sub- safekeeping Statement	:4!c//1!a	CONS	1.8.4	14
M	:16S:	End of Block	GENL			15
End of Sequence A General Information						
Optional Repetitive Sequence B Sub-safekeeping account						
M	:16R:	Start of Block	SUBSAFE			16
O	:95a:	Party/ Account Owner	P or R	ACOW	1.8.21	18
M	:97a:	Account/ Safekeeping account	A or B	SAFE	1.8.22	19
M	:17B:	Flag/Activity flag	:4!c//1!a	ACTI	1.8.4	20
Optional Repetitive Subsequence B1 Financial Instrument						
M	:16R:	Start of Block	FIN			21
O	:35B:	Identification of the Financial Instrument	[ISIN1!e12!c][4*35x]		1.8.13	22
Optional Subsequence B1a Financial Instrument Attributes						
M	:93B:	Balance/Aggre gate Balance	:4!c/[8c]/4!c/[N]15d	AGGR	1.8.19	41
O	:93B:	Available Balance	:4!c/[8c]/4!c/[N]15d	AVAI	1.8.19	41
O	:93B:	Not Available Balance	:4!c/[8c]/4!c/[N]15d	NAVL	1.8.19	41
Optional Repetitive Subsequence B1b Sub-Balance (not considered)						
Optional Repetitive Subsequence B1b Quantity Breakdown (not considered)						
M	:16S:	End of Block	FIN			72
End of Subsequence B1 Financial Instrument						
M	:16S:	End of Block	SUBSAFE			73
End of Sequence B Sub-safekeeping account						
Optional Repetitive Sequence C Additional Information (not considered)						

3.7.2. Examples of MT535 Statement of Holdings

Example 1.

This is an example of a Statement of Holdings sent by the Depository (BIC DEPORUMM) to the account owner (OAO CB “Telecom”, BIC TELERUMM) to report on the securities held in the account 1111NM on the reported date – the 23rd of September 2004.

Statement number – REP5351111NM2309.

Preparation date and time of the statement – the 24th of September 2004, 06:00.

The statement reports holdings reflecting situation at the end of operation day (the 23rd of September 2004) .

The statement is daily (indicator DAIL), it gives complete information on the quantity and status of securities held in the safekeeping account based on the end of operation day status (indicator COMP); it is a depository statement (indicator CUST).

The statement in this example is reporting on three securities held in the safekeeping account:

- OAO Tatneft, ordinary shares of the third issue (total quantity of the securities in the safekeeping account – 88000, total quantity available for operations – 8000, blocked in the process of settlement - 80000);
- NK Lukoil (total quantity of the securities in the safekeeping account – 100000, total quantity available for operations – 100000);
- OAO ‘GAZ’ (total quantity of the securities in the safekeeping account – 175000, quantity of securities awaiting re-registration – 75000, total quantity available for operations – 100000).

Sender of MT535 – DEPORUMM

Receiver of MT535 – TELERUMM

Message structure:

```
:16R:GENL
:28E:1/ONLY
:20C::SEME//REP5351111NM2309
:23G:NEWM
:98C::PREP//20040924060000
:98A::STAT//20040923
:22F::SFRE//DAIL
:22F::CODE//COMP
:22F::STTY//CUST
:97A::SAFE//1111NM
:17B::ACTI//Y
:17B::CONS//Y
:16S:GENL
:16R:SUBSAFE
:97A::SAFE//1111NM
:17B::ACTI//Y
:16R:FIN
:35B:ISIN RU0009033591
/XX/CORP/DEPO/54327RT
/RU/1-03-00161-A
'OAO "TATNEFTX" AO3
:93B::AGGR//UNIT/88000,
:16R:SUBBAL
:93C::BLOC//UNIT/NAVL/80000,
:16S:SUBBAL
:16R:SUBBAL
```

:93C::TAVI//UNIT/AVAI/8000,
:16S:SUBBAL
:16S:FIN
:16R:FIN
:35B:ISIN RU0009024277
/XX/CORP/DEPO/56734LU
/RU/1-01-00077-A
'NK LUKOIL
:93B::AGGR//UNIT/100000,
:16R:SUBBAL
:93C::TAVI//UNIT/AVAI/100000,
:16S:SUBBAL
:16S:FIN
:16R:FIN
:35B:ISIN RU0009034268
/XX/CORP/DEPO/56734GZ
/RU/1-01-00029-A
'OAO "GAZ"
:93B::AGGR//UNIT/175000,
:16R:SUBBAL
:93C::REGO//UNIT/NAVL/75000,
:16S:SUBBAL
:16R:SUBBAL
:93C::TAVI//UNIT/AVAI/100000,
:16S:SUBBAL
:16S:FIN
:16S:SUBSAFE

Example 2.

This is an example of a Statement of Holdings sent by the Depository (BIC DEPORUMM) to the account owner (ABC Broker, BIC BROKRUMM) to report on the securities held in the account 2222 on the reported date – the 6th of June 2004.

The statement is reporting only on the total quantity of the securities held in the Client's account. The statement does not contain information on the current status of these securities.

Statement number – REP53522220606.

Preparation date and time of the statement – the 7th of June 2004, 06:05.

The statement reports holdings reflecting situation at the end of operation day (the 6th of June 2004).

The statement is daily (indicator DAIL), it gives complete information on the quantity of securities held in the safekeeping account based on the end of operation day status (indicator COMP); it is a depository statement (indicator CUST).

The statement in this example is reporting on three securities held in two sections (subaccounts) of the safekeeping account 2222 - .222AC and 2222AB:

- OAO "X-neft", ordinary shares of the third issue (total quantity of the securities in the safekeeping account – 55000);

- RAO EeS, ordinary shares (total quantity of the securities in the safekeeping account – 4000);

OAO 'GAZ' are held on 2222AB subaccount, total quantity of the securities in the safekeeping account – 37400.

Sender of MT535 – DEPORUMM
Receiver of MT535 – BROKRUMM

Message structure:

```
:16R:GENL
:28E:1/ONLY
:20C::SEME// REP53522220606
:23G:NEWM
:98C::PREP//200400607060500
:98A::STAT//20040606
:22F::SFRE//DAIL
:22F::CODE//COMP
:22F::STTY//CUST
:97A::SAFE//2222
:17B::ACTI//Y
:17B::CONS//Y
:16S:GENL
:16R:SUBSAFE
:97A::SAFE//2222
:17B::ACTI//Y
:16R:FIN
:35B:ISIN RU0006733556
/XX/CORP/DEPO/54327RT
/RU/2-07-03-00345-A
'OAO "IKS-NEFTX" AO3
:93B::AGGR//UNIT/55000,
:16S:FIN
:16R:FIN
:35B:ISIN RU0008959655
/XX/CORP/DEPO/65432ES
/RU/1-01-00034-A
'RAO EeS
:93B::AGGR//UNIT/4000,
:16S:FIN
:16R:FIN
:35B:ISIN RU0009034268
/XX/CORP/DEPO/56734GZ
/RU/1-01-00029-A
'OAO "GAZ"
:93B::AGGR//UNIT/37400,
:16S:FIN
:16S:SUBSAFE
```

3.8.MT536 STATEMENT OF TRANSACTIONS

This message is sent by an account servicer (account servicing institution) to an account owner or its designated agent.

This message is used to provide the details of increases and decreases of holdings which occurred during a specified period, for all or selected securities in the specified safekeeping account or sub-safekeeping account which the account servicer holds for the account owner.

This message may also be used to respond to a request for statement/status advice, i.e., the MT 549 Request for Statement/Status Advice and to report that there are no transactions for the specified period of time:

- for the operational day (indicator DAIL)
- for the month (indicator MNTH)
- for the year (indicator YEAR)
- for the week (indicator WEEK).

3.8.1. Format Specifications

Status	Tag	Detailed Field Name	Content/Options	Qualifier	№ RUS	№ SWIFT User Handbook
Mandatory Sequence A General Information						
M	:16R:	Start of Block	GENL			1
M	:28E:	Page Number/Continuation Indicator	5n/4!c		1.8.12	2
O	:13a:	Statement Number	A or J	STAT	1.8.3	3
M	:20C:	Sender's Message Reference	:4!c//16x	SEME	1.8.6	4
M	:23G:	Function of the Message	4!c/[4!c]		1.8.9	5
O	:98a:	Statement Date/Time	A or C	PREP	1.8.23	6
O	:69a:	Statement Period	A or C	STAT	1.8.15	7
O	:22F:	Indicator/Complete/Updates Indicator	:4!c/[8c]/4!c	CODE	1.8.8	8
O	:22F:	Indicator/Statement Frequency Indicator	:4!c/[8c]/4!c	SFRE	1.8.8	8

Optional Repetitive Subsequence A1 Linkages (not considered)						
O	:95a:	Party/ Account Owner	P or R	ACOW	1.8.21	13
M	:97a:	Account/ Safekeeping account	A or B	SAFE	1.8.22	14
M	:17B:	Flag/Activity flag	:4!c//1!a	ACTI	1.8.4	15
M	:17B:	Flag/Sub- safekeeping Statement	:4!c//1!a	CONS	1.8.4	15
M	:16S:	End of Block	GENL			16
End of Sequence A General Information						
Optional Repetitive Sequence B Sub-safekeeping account						
M	:16R:	Start of Block	SUBSAFE			17
O	:95a:	Party/ Account Owner	P or R	ACOW	1.8.21	18
M	:97a:	Account/ Safekeeping account	A or B	SAFE	1.8.22	19
M	:17B:	Flag/Activity flag	:4!c//1!a	ACTI	1.8.4	21
Optional Repetitive Subsequence B1 Financial Instrument						
M	:16R:	Start of Block	FIN			22
O	:35B	Identification of the Financial Instrument	[ISIN1!e12!c][4*35x]		1.8.13	23
Mandatory Repetitive Subsequence B1a Transaction						
M	:16R:	Start of Block	TRAN			28
Mandatory Repetitive Subsequence B1a1 Linkages						
M	:16R:	Start of Block	LINK			29
M	:20C:	Related Message Reference	:4!c//16x	RELA	1.8.7	31
M	:16S:	End of Block	LINK			32
End of Subsequence B1a1 Linkages						
Optional Subsequence B1a2 Transaction Details						
M	:16R:	Start of Block	TRANSDet			33
M	:36B:	Posting Quantity	:4!c//4!c/[N]15 d	PSTA	1.8.14	35
O	:19A:	Posting Amount	:4!c//[N]3!a15 d	PSTA	1.8.5	37
M	:22F:	Transaction indicator	:4!c/[8c]/4!c	TRAN	1.8.8	38
M	:22H:	Payment indicator	:4!c//4!c	PAYM	1.8.8	38
M	:22H:	Receive/Deliv ery indicator	:4!c//4!c	REDE	1.8.8	38

M	:22F:	Type of Settlement Transaction Indicator	:4!c/[8c]/4!c	SETR	1.8.8	38
M	:98a:	Effective Settlement Date/Time	A or C	ESET	1.8.23	39
O	:98a:	Settlement Date/Time	A,B or C	SETT	1.8.23	40
O	:70E	Transaction Details Narrative	:4!c//10*35x	TRDE	1.8.16	41
Optional Repetitive Subsequence B1a2A Settlement Parties						
M	:16R:	Start of Block	SETPRTY			42
M	:95a:	Party	C,P,Q or R		1.8.21	43
O	:97a:	Account/Safek eeping account	A or B	SAFE	1.8.22	44
M	:16S:	End of Block	SETPRTY			46
End of Subsequence B1a2A Settlement Parties						
M	:16S:	End of Block	TRANSDET			47
End of Subsequence B1a2 Transaction Details						
M	:16S:	End of Block	TRAN			48
End of Subsequence B1a Transaction						
M	:16S:	End of Block	FIN			49
End of Subsequence B1 Financial Instrument						
M	:16S:	End of Block	SUBSAFE			50
End of Sequence B Sub-safekeeping account						
Optional Repetitive Sequence C Additional Information (not considered)						

3.8.2. Examples of MT536 Statement of Transactions

Example 1.

This is an example of a Statement of Transactions sent by the Depository (BIC DEPORUMM) to the account owner (OAO CB “Telecom”, BIC TELERUMM) with details of the transactions for the Client’s account 111NM for the 23rd of September 2004.

The statement is reporting on three transactions:

Instruction to receive securities from an institution’s account opened at the Registrar (Example 1 section 2.1.3)

Receive against payment instruction (Example 1 section 2.2.2)

Instruction to deliver securities from an account with a Depository/Custodian to an institution’s account in the registry (Example 2 section 2.3.3).

Example 2.

Statement number – REP1111NM2309.

Preparation date and time of the statement – the 24th of September 2004, 07:00.

The statement reports transactions on 23rd of September 2004.

The statement is daily (indicator DAIL), it gives complete information on the transactions for the specified period (indicator COMP).

This statement contains the main details of the type of settlement transaction, instruction number, settlement transaction indicators, quantity of settled securities, settlement amount, effective settlement date, account number and name of the counterparty.

Sender of MT536 DEPORUMM
Receiver of MT536 TELERUMM

Message structure:

:16R:GENL
:28E:1/ONLY
:20C::SEME//REP1111NM2309
:23G:NEWM
:98C::PREP//20040924070000
:69A::STAT//20040923/20040923
:22F::SFRE//DAIL
:22F::CODE//COMP
:97A::SAFE//1111NM
:17B::ACTI//Y
:17B::CONS//Y
:16S:GENL
:16R:SUBSAFE
:97A::SAFE//1111NM
:17B::ACTI//Y
:16R:FIN
:35B:ISIN RU0006733556
/XX/CORP/DEPO/54327RT
/RU/2-07-03-00345-A
'OAO "IKS-NEFTX" AO3
:16R:TRAN
:16R:LINK
:13A::LINK//540
:20C::RELA//ANF-34/DF
:16S:LINK
:16R:TRANSDDET
:36B::PSTA//UNIT/8000,
:22F::TRAN//SETT
:22H::REDE//RECE
:22H::PAYM//FREE
:22F::SETR//OWNE
:98A::ESET//20040923
:16R:SETPRTY
:95Q::PSET//REGISTRAR
:16S:SETPRTY
:16R:SETPRTY
:95Q::DEAG//"ZAO KOMPANIa" "Alliance"
:16S:SETPRTY
:16S:TRANSDDET
:16S:TRAN

:16S:FIN
:16R:FIN
:35B:ISIN RU0009024277
/XX/CORP/DEPO/56734LU
/RU/1-01-00077-A
NK LUKOIL
:16R:TRAN
:16R:LINK
:13A::LINK//541
:20C::RELA//TEN004-346A
:16S:LINK
:16R:TRANSDET
:36B::PSTA//UNIT/4000,
:19A::PSTA//USD100000,
:22F::TRAN//SETT
:22H::REDE//RECE
:22H::PAYM//APMT
:22F::SETR//TRAD
:98A::ESET//20040923
:98A::TRAD//20040916
:16R:SETPRTY
:95P::PSET//DEPORUMM
:16S:SETPRTY
:16R:SETPRTY
:95P::DEAG//BROKRUMM
:16S:SETPRTY
:16S:TRANSDET
:16S:TRAN
:16S:FIN
:16R:FIN
:35B:ISIN RU0009034268
/XX/CORP/DEPO/56734GZ
/RU/1-01-00029-A
'OAO "GAZ"
:16R:TRAN
:16R:LINK
:13A::LINK//542
:20C::RELA//SAMP542/OWN
:16S:LINK
:16R:TRANSDET
:36B::PSTA//UNIT/3000,
:19A::PSTA//USD10000,
:22F::TRAN//SETT
:22H::REDE//DELI
:22H::PAYM//FREE
:22F::SETR//TRAD
:98A::ESET//20040920
:98A::SETT//20040923
:98A::TRAD//20040911
:16R:SETPRTY
:95Q::PSET//REGISTRAR

:16S:SETPRTY
:16R:SETPRTY
:95Q::REAG//OAO "TELESTAR"
:16S:SETPRTY
:16S:TRANSDET
:16S:TRAN
:16S:FIN
:16S:SUBSAFE

3.9.MT537 STATEMENT OF PENDING TRANSACTIONS

This message is sent by an account servicer (account servicing institution) to an account owner or its designated agent. This message is used to provide, as at a specified time, the details of pending increases and decreases of holdings, for all or selected securities in a specified safekeeping account, for all or selected reasons why the transaction is pending.

The statement may also include future settlement or forward transactions which have become binding on the account owner.

This message may also be used to respond to a request for statement/status advice, that is, the MT 549 Request for Statement/Status Advice and to report that there are no pending transactions.

3.9.1. Format Specifications

Status	Tag	Detailed Field Name	Content/Options	Qualifier	№ RUS	№ SWIFT User Handbook
Mandatory Sequence A General Information						
M	:16R:	Start of Block	GENL			1
M	:28E:	Page Number/Continuation Indicator	5n/4!c		1.8.12	2
O	:13a:	Statement Number	A or J	STAT	1.8.3	3
M	:20C:	Sender's Message Reference	:4!c//16x	SEME	1.8.6	4
M	:23G:	Function of the Message	4!c[/4!c]		1.8.9	5
O	:98a:	Statement Date/Time	A or C	STAT	1.8.23	6
O	:22F:	Indicator/Complete/Updates Indicator	:4!c/[8c]/4!c	CODE	1.8.8	7
O	:22F:	Indicator/Statement Frequency Indicator	:4!c/[8c]/4!c	SFRE	1.8.8	7
M	:22H:	Indicator/Statement structure type	:4!c/[8c]/4!c	STST	1.8.8	7
Optional Repetitive Subsequence A1 Linkages (not considered)						
O	:95a:	Party/ Account Owner	P or R	ACOW	1.8.21	12
M	:97a:	Account/ Safekeeping account	A or B	SAFE	1.8.12	13

M	:17B:	Flag/Activity flag	:4!c//1!a	ACTI	1.8.4	14
M	:16S:	End of Block	GENL			15
End of Sequence A General Information						
Optional Repetitive Sequence B Status						
M	:16R:	Start of Block	STAT			16
M	:25D:	Status	:4!c/[8c]/4!c		1.8.11	17
Optional Repetitive Subsequence B1 Reason						
M	:16R:	Start of Block	REAS			18
M	:24B:	Reason	:4!c/[8c]/4!c		1.8.10	19
O	:70D:	Narrative/ Reason narrative	:4!c//6*35x	REAS	1.8.16	20
M	:16S:	End of Block	REAS			21
End of Subsequence B1 Reason						
Mandatory Repetitive Subsequence B2 Transaction						
M	:16R:	Start of Block	TRAN			22
Mandatory Repetitive Subsequence B2a Linkages						
M	:16R:	Start of Block	LINK			23
M	:20C:	Related Message Reference	:4!c//16x	RELA	1.8.7	25
M	:16S:	End of Block	LINK			26
End of Subsequence B2a Linkages						
Optional Subsequence B2b Transaction Details						
M	:16R:	Start of Block	TRANSDET			27
M	:35B:	Identification of the Financial Instrument	[ISIN!e12!c] [4*35x]		1.8.13	29
M	:36B:	Posting Quantity	:4!c//4!c/[N]15 d	PSTA	1.8.14	30
O	:19A:	Posting Amount	:4!c//[N]3!a15 d	PSTA	1.8.5	31
M	:22F:	Transaction indicator	:4!c/[8c]/4!c	TRAN	1.8.8	32
M	:22H:	Payment indicator	:4!c//4!c	PAYM	1.8.8	32
M	:22H:	Delivery/Recei pt indicator	:4!c//4!c	REDE	1.8.8	32
M	:22F:	Type of Settlement Transaction Indicator	:4!c/[8c]/4!c	SETR	1.8.8	32
M	:98a:	Settlement Date/Time	A,B or C	SETT	1.8.23	33
O	:70E	Transaction Details Narrative	:4!c//10*35x	TRDE	1.8.16	34
Optional Repetitive Subsequence B2b1 Settlement Parties						
M	:16R:	Start of Block	SETPRTY			35

M	:95a:	Party	C,P,Q or R		1.8.21	36
O	:97a:	Account/Safek eeping account	A or B	SAFE	1.8.22	37
M	:16S:	End of Block	SETPRTY			39
End of Subsequence B2b1 Settlement Parties						
M	:16S:	End of Block	TRANSDET			40
End of Subsequence B2b Transaction Details						
M	:16S:	End of Block	TRAN			41
End of Subsequence B2 Transaction						
M	:16S:	End of Block	STAT			42
End of Sequence B Status						
Optional Repetitive Sequence C Transactions						
M	:16R:	Start of Block	TRANS			43
Mandatory Repetitive Subsequence C1 Linkages						
M	:16R:	Start of Block	LINK			44
M	:20C:	Related Message Reference	:4!c//16x	RELA	1.8.7	46
M	:16S:	End of Block	LINK			47
End of Subsequence C1 Linkages						
Optional Subsequence C2 Transaction Details						
M	:16R:	Start of Block	TRANSDET			48
M	:35B:	Identification of the Financial Instrument	[ISIN!e12!c] [4*35x]		1.8.13	50
M	:36B:	Posting Quantity	:4!c//4!c/[N]15 d	PSTA	1.8.14	51
O	:19A:	Posting Amount	:4!c//[N]3!a15 d	PSTA	1.8.5	52
M	:22F:	Transaction indicator	:4!c/[8c]/4!c	TRAN	1.8.8	53
M	:22H:	Payment indicator	:4!c//4!c	PAYM	1.8.8	53
M	:22H:	Delivery/Recei pt indicator	:4!c//4!c	REDE	1.8.8	53
M	:22F:	Type of Settlement Transaction Indicator	:4!c/[8c]/4!c	SETR	1.8.8	53
M	:98a:	Settlement Date/Time	A,B or C	SETT	1.8.23	54
O	:70E	Transaction Details Narrative	:4!c//10*35x	TRDE	1.8.16	55
Optional Repetitive Subsequence C2a Settlement Parties						
M	:16R	Start of Block	SETPRTY			56
M	:95a:	Party	C,P,Q or R		1.8.21	57
O	:97a:	Account/Safek eeping account	A or B	SAFE	1.8.22	58
M	:16S:	End of Block	SETPRTY			60

End of Subsequence C2a Settlement Parties					
M	:16S:	End of Block	TRANSD		61
End of Subsequence C2 Transaction Details					
Optional Repetitive Subsequence C3 Status					
M	:16R	Start of Block	STAT		62
M	:25D:	Status	:4!c/[8c]/4!c	1.8.11	63
Optional Repetitive Subsequence C3a Reason					
M	:16R:	Start of Block	REAS		64
M	:24B:	Reason	:4!c/[8c]/4!c	1.8.10	65
M	:70D:	Reason	:4!c//6*35x	REAS	1.8.16
		Narrative			
M	:16S:	End of Block	REAS		67
End of Subsequence C3a Reason					
M	:16S:	End of Block	STAT		68
End of Subsequence C3 Status					
M	:16S:	End of Block	TRANS		69
End of Sequence C Transactions					
Optional Sequence D Additional Information (not considered)					

3.9.2. Examples of Statement of Pending Transactions

Example 1.

This is an example of a Statement of Pending Transactions sent by the Depository (BIC DEPORUMM) to the account owner (ABC Broker, BIC BROKRUMM) to report on pending transactions for the account 2222.

The statement is prepared by the Depository as response to the Client's request for statement MT549 (described in Example 4 section 3.6.2 of this document) and reports on the unsettled Client's instruction (described in Example 3 section 3.5.4 of this document).

Statement number – REP53722222NM309.

Preparation date and time of the statement – the 23rd of September 2004, 17:00.

The statement reports pending transactions at the 23rd of September 2004.

The statement is being sent in response to a request of the Receiver (indicator ADHO), it gives complete information on the transactions for the specified period (indicator COMP).

The statement is reporting per statuses (indicator STAT) and contains details of the transactions with pending settlement status (status SETT//PEND), reason code – LACK, insufficient deliverable securities in the Client's account (code PEND//LACK).

The statement contains the main details of the settlement instruction, safekeeping account number, quantity of securities, settlement amount, expected settlement date, account number and name of the counterparty.

Sender of MT537 DEPORUMM

Receiver of MT537 BROKRUMM

Message structure:

:16R:GENL

:28E:1/ONLY

:20C::SEME//REP53722222NM2309

:23G:NEWM
:98C::PREP//20040923170500
:98A::STAT//20040923
:22H::STST//STAT
:22F::SFRE//ADHO
:22F::CODE//COMP
:16R:LINK
:13A::LINK//549
:20C::RELA//12345/000123
:16S:LINK
:97A::SAFE//2222
:17B::ACTI//Y
:16S:GENL
:16R:STAT
:25D::SETT//PEND
:16R:REAS
:24B::PEND//LACK
:16S:REAS
:16R:TRAN
:16R:LINK
:13A::LINK//543
:20C::RELA//DVP040602/543
:16S:LINK
:16R:TRANSDET
:35B:ISIN RU0009024277
NK LUKOIL
:36B::PSTA//UNIT/4000,
:19A::PSTA//USD100000,
:22F::TRAN//SETT
:22H::REDE//DELI
:22H::PAYM//APMT
:22F::SETR//TRAD
:98A::SETT//20040923
:16R:SETPRTY
:95P::PSET//DEPORUMM
:16S:SETPRTY
:16R:SETPRTY
:95P::REAG//TELERUMM
:97A::SAFE//1111NM
:16S:SETPRTY
:16S:TRANSDET
:16S:TRAN
:16S:STAT

3.10. MT 578 SETTLEMENT ALLEGEMENT

This message is sent by an account servicer (account servicing institution) to an account owner or its designated agent. This message is used to:

- advise the account owner that a counterparty has alleged an instruction against account owner's account at the account servicer and the account servicer could not find the corresponding instruction of the account owner (the function of the message is NEWM).
- request the cancellation of a previously sent allegation because of a mistake or because the alleging party cancelled instruction (the function of the message is CANC).
- Acknowledge that a previously sent allegation is no longer outstanding (the function of the message is REMO).

3.10.1. Format Specifications

Status	Tag	Detailed Field Name	Content/Options	Qualifier	№ RUS	№ SWIFT User Handbook
Mandatory Sequence A General Information						
M	:16R:	Start of Block	GENL			1
M	:20C:	Sender's Message Reference	:4!c//16x	SEME	1.8.6	2
M	:23G:	Function of the Message	4!c[4!c]		1.8.9	3
O	:98a:	Preparation Date/Time	A or C	PREP	1.8.23	4
Optional Repetitive Subsequence A1 Linkages						
M	:16R:	Start of Block	LINK			5
M	:20C:	Linked Message Reference	:4!c//16x	RELA	1.8.7	8
M	:16S:	End of Block	LINK			9
End of Subsequence A1 Linkages						
M	:16S:	End of Block	GENL			10
End of Sequence A General Information						
Mandatory Sequence B Trade Details						
M	:16R:	Start of Block	TRADDET			11
M	:98a:	Settlement Date/Time	A,B or C	SETT	1.8.23	13
O	:98a:	Trade Date/Time	A,B or C	TRAD	1.8.23	13
M	:35B:	Identification of the Financial Instrument	[ISIN1!e12!c][4*35x]		1.8.13	16
Optional Subsequence B1 Financial Instrument Attributes (not considered)						
M	:22H:	Payment indicator	:4!c//4!c	PAYM	1.8.8	31

M	:22H:	Receipt/Delivery Indicator	:4!c//4!c	REDE	1.8.8	31
M	:16S:	End of Block	TRADDET			32
End of Sequence B Settlement Transaction Details						
Mandatory Repetitive Sequence C Financial Instrument/Account						
M	:16R:	Start of Block	FIAC			33
M	:36B:	Quantity of Financial Instrument	:4!c//4!c/15d	SETT	1.8.14	34
O	:95a:	Party/Account Owner	P or R	ACOW	1.8.21	36
M	:97a:	Account/Safekeeping account	A or B	SAFE	1.8.22	37
M	:16S:	End of Block	FIAC			46
End of Sequence C Financial Instrument/Account						
Optional Sequence D Two Leg Transaction Details (not considered)						
Mandatory Sequence E Settlement Details						
M	:16R:	Start of Block	SETDET			56
M	:22F:	Indicator of the operation type	:4!c/[8c]/4!c	SETR	1.8.8	57
Mandatory Repetitive Subsequence E1 Settlement Parties						
M	:16R:	Start of Block	SETPRTY			58
M	:95a:	Place of Settlement	C, P or Q	PSET	1.8.21	59
M	:95a:	Party	S, P, Q or R		1.8.21	59
O	:97a:	Safekeeping Account	A or B	SAFE	1.8.22	60
O	:70a:	Narrative	C, D or E		1.8.16	63
M	:16S:	End of Block	SETPRTY			64
End of Subsequence E1 Settlement Parties						
Optional Repetitive Subsequence E2 Cash Parties (not considered)						
M	:16R:	Start of Block	CSHPRTY			65
M	:95a:	Party	S, P, Q or R		1.8.21	66
O	:97A:	Cash account	:4!c//35x	CASH	1.8.22	67
M	:16S:	End of Block	CSHPARTY			69
End of Subsequence E2 Cash Parties						
Optional Repetitive Subsequence E3 Amount						
M	:16R:	Start of Block	AMT			70
M	:19A:	Amount	:4!c//[N]3!a15d	SET	1.8.5	71
M	:16S:	End of Block	AMT			74
End of Subsequence E3 Amount						
M	:16S:	End of Block	SETDET			75
End of Sequence E Settlement Details						
Optional Repetitive Sequence F Other Parties (not considered)						

3.10.2. Examples of Settlement Allegement

Example 1.

This is an example of Settlement Allegement sent by the depository DEPORUMM to the owner of the account OAO CB “Telecom” (BIC TELERUMM) and contains information about Delivery Free of Payment instruction MT 542, received from ABC Broker (BIC BROKRUMM).

Instruction number – ALLEGM1111/2222.

Preparation date/time – the 22nd September 2004, 18:20:25.

Number of the settlement allegement – 234521/45NP-1.

Settlement date – the 23rd of September 2004.

Trade date – the 16th of September 2004.

Financial Instrument is defined by the following details:

ISIN RU0008959655

Narrative description of RAO EeS securities (Russia) with transliteration indicator – ‘RAOEeS

The rules of financial instrument’s indication are defined in section 1.8.5 of this document.

Quantity of financial instrument to be settled – 1500 units.

Account number for money transaction - 1111

Type of Settlement Transaction – settlement of a trade, indicator SETR//TRAD, delivery of the counterparty ABC Broker (REDI//DELI), without payment (PAYM//FREE).

Name of the owner of the nominee safekeeping account from which the securities should be delivered – ABC Broker, (BIC BROKRUMM, account number 2222).

Transaction basis is the contract of purchase and sale №45HII-1 dated the 16th of September 2004. Russian letters in the contract number should be transliterated.

Place of Settlement is a depository (BIC DEPORUMM) that services the accounts of the sender of the message OAO CB “Telecom” (account number 1111) and its agent ABC Broker (account number 2222, BIC BROKRUMM)

Message flow.

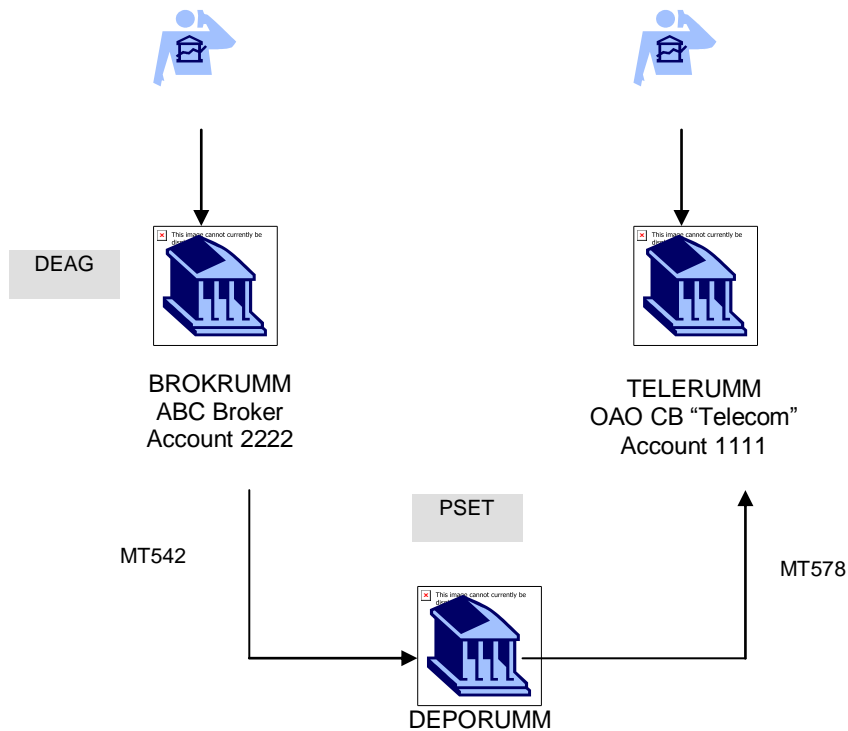

Sender of MT578 DEPORUMM
Receiver of MT578 TELERUMM

Message structure.

```
:16R:GENL
:20C::SEME//ALLEGE1111/2222
:23G:NEWM
:98C::PREP//20040922182025
:16R:LINK
:16R:GENL
:16R:TRADDET
:98A::SETT//20040923
:98A::TRAD//20040916
:35B:ISIN RU0008959655
'RAO EeS
:22H::REDE//DELI
:22H::PAYM//FREE
:16S:TRADDET
:16R:FIAC
:36B::SETT//UNIT/1500,
:97A::SAFE//1111
:16S:FIAC
:16R:SETDET
:22F::SETR//TRAD
:16R:SETPRTY
:95P::PSET//DEPORUMM
```

:16S:SETPRTY
:16R:SETPRTY
:95P::DEAG//BROKRUMM
:97A::SAFE//2222
:70E::DECL//TYPE/BYSA/NUMB/45'NP-1'/DATE/20040916
:16S:SETPRTY
:16S:SETDET

4. CORPORATE ACTION MESSAGES

4.1. MT 564 CORPORATE ACTION NOTIFICATION

This message is sent by an account servicer (account servicing institution) to an account owner or its designated agent. This message is used to provide an account owner with the details of a corporate action event along with the possible elections or choices available to the account owner. It can be initially sent as a preliminary advice (function NEWM) and subsequently replaced by another MT 564 with complete or confirmed information (function REPL).

This message will also be used to provide the account owner with details of the impact a corporate action event will have on a safekeeping or cash account, for example, entitlement calculation.

This message may also be sent by an information provider, such as a market data provider or a stock exchange, to provide details of a corporate action event.

This message may also be used to:

- request the cancellation of a previously sent corporate action notification (function CANC)
- re-send a corporate action notification previously sent (function DUPL)
- as a reminder of the coming corporate action in case of necessity providing to the account owners the instruction (function RMDR)
- provide a third party with a copy of the message (function COPY)
- request the cancellation of a previously sent corporate action notification in case of cancellation of the corporate action itself (function WITH)
- carrying out additional actions on the corporate action (function ADDB)
- requesting list of the beneficial owners/depositors (type of corporate action DSCL), in this case in accordance with the Russian legislation identification of basis/reasons of the list request is mandatory (link to the corporate action – meeting, distribution and/or to the request of the issuer/designated agent/Registrar)

In addition this message may be used to notify about the procedure of automatic compensation by the international depository for the transaction “delivery versus payment” settlements.

4.1.1. Format Specifications

Status	Tag	Detaild Field Name	Content/Options	Qualifier	Nº RUS	Nº SWIFT User Handbook
--------	-----	--------------------	-----------------	-----------	--------	------------------------

Mandatory Sequence A General Information

M	:16R:	Start of Block	GENL			1
---	-------	----------------	------	--	--	---

O	:28E:	Page number/Continuation Indicator	5n/4!c		1.8.12	2
M	:20C:	Sender's Message Reference	:4!c//16x	4!c	1.8.6 1.8.7	3
M	:23G:	Function of the Message	4!c/[4!c]	4!c	1.8.9	4
M	:22F:	Indicator	:4!c/[8c]/4!c	4!c	1.8.8	5
O	:98a:	Preparation Date/Time	A or C	PREP	1.8.4	6
M	:25D:	Status code/Processing Status	:4!c/[8c]/4!c	PROC	1.8.11	7
Optional Repetitive Subsequence A1 Linkages						
M	:16R:	Start of Block	LINK			8
O	:22F:	Indicator/Link age Type Indicator	:4!c/[8c]/4!c	LINK	1.8.8	9
O	:13a:	Number Identification/ Linked message	A or B	LINK	1.8.3	10
M	:20C:	Linked Message Reference	:4!c//16x	4!c	1.8.7	11
M	:16S:	End of Block	LINK			12
End of Subsequence A1 Linkages						
M	:16S:	End of Block	GENL			13
End of Sequence A General Information						
Mandatory Sequence B Underlying Securities						
M	:16R:	Start of Block	USECU			14
M	:35B:	Identification of the Financial Instrument	[ISIN1!e12!c][4*35x]		1.8.13	15
Optional Subsequence B1 Financial Instrument Attributes						
M	:16R:	Start of Block	FIA			16
O	:94B:	Place/Place of Listing	B	PLIS	1.8.20	17
O	:22F:	Indicator/Method of Interest Computation Indicator	F	MICO	1.8.8	18
O	:12a:	Type of Financial Instrument	A, B or C	4!c	1.8.2	19
O	:11A:	Currency/Currency of Denomination	A	DENO	1.8.1	20

O	:98A:	Date/Time	A,B or C		1.8.23	21
O	:92a:	Rate	A or K		1.8.18	22
O	36B	Quantity of Financial Instrument	B		1.8.14	23
M	:16S:	End of Block	FIA			24
End of Subsequence B1 Financial Instrument Attributes						
Mandatory Repetitive Subsequence B2 Account Information						
M	:16R:	Start of Block	ACCTINFO			25
O	:95a:	Party/Account Owner	P or R	ACOW	1.8.21	26
M	:97a:	Account/Safek eeping Account	A or C	SAFE	1.8.22	27
O	:94a:	Place/Place of Safekeeping	B,C or F	SAFE	1.8.20	28
O	:93a:	Balance	B or C	4!c	1.8.19	29
M	:16S:	End of Block	ACCTINFO			30
End of Subsequence B2 Account Information						
M	:16S:	End of Block	USECU			31
End of Sequence B Underlying Securities						
Optional Sequence C Intermediate Securities (not applicable for the Russian securities)						
M	:16R:	Start of Block	INTSEC			32
M	:35B:	Identification of the Financial Instrument	[ISIN!e12!c] [4*35x]	4!c	1.8.13	33
O	:36a:	Quantity of Financial Instrument/Qu antity of Intermediate Securities	B or C	QINT	1.8.14	34
O	:93A:	Balance	B or C	4!c	1.8.19	35
O	:22F:	Indicator	:4!c/[8c]/4!c	4!c	1.8.8	36
O	:92D:	Rate (Intermediate Securities to Underlying)	:4!c//15d/15d	RTUN	1.8.18	37
O	:90B:	Price/Market Price	:4!c//4!c/3!a15 d	MRKT	1.8.17	38
O	:98a:	Date/Time	A or B	4!c	1.8.23	39
O	:69a:	Period/Trading Period	A,B,C,D,E or F	TRDP	1.8.15	40
M	:16S:	End of Block	INTSEC			41
End of Sequence C Intermediate Securities						
Optional Sequence D Corporate Action Details						
M	:16R:	Start of Block	CADETL			42
M	:98a:	Date/Time	A,B,C or E	4!c	1.8.23	43
O	:69a:	Period	A,B,C,D,E,F or J	4!c	1.8.15	44

O	:99A:	Number Count/Number of Days Accrued	:4!c//[N]3!n	DAAC	1.8.14	45
O	:92a:	Rate	A,F or K	4!c	1.8.18	46
O	:90a:	Price	A,B or E	4!c	1.8.17	47
O	:36a:	Quantity of Financial Instrument	B or C	4!c	1.8.14	48
O	:13a:	Number Identification/ Coupon Number	A or B	COUP	1.8.3	49
O	:17B:	Flag	:4!c//1!a	4!c	1.8.4	50
O	:22F:	Indicator	:4!c/[8c]/4!c	4!c	1.8.8	51
O	:94G:	Place	:4!c//2*35x	4!c	1.8.20	52
O	:70a:	Narrative	E or G	4!c	1.8.16	53
M	:16S:	End of Block	CADETL			54

End of Sequence D Corporate Action Details

Optional Repetitive Sequence E Corporate Action Options

M	:16R:	Start of Block	CAOPTN			55
M	:13A:	Number Identification/ CA Option Number	!4!c//3!c	CAON	1.8.3	56
O	:22F:	Indicator	:4!c/[8c]/4!c	4!c	1.8.8	57
O	:94C:	Place	:4!c//2!a	4!c	1.8.20	58
O	:11A:	Currency/Curr ency option	:4!c//3!a	OPTN	1.8.1	59
M	:17B:	Flag	:4!c//1!a	4!c	1.8.8	60
O	:35B:	Identification of the Financial Instrument	[ISIN1!e12!c] [4*35x]		1.8.13	61
O	:98a:	Date/Time	A,B,C or E or F	4!c	1.8.23	62
O	:69a:	Period	A,B,C,D,E,F or J	4!c	1.8.15	63
O	:92a:	Rate	A,F,J,K or M	4!c	1.8.18	64
O	:90a:	Price	A,B, or E	4!c	1.8.17	65
O	:36a:	Quantity of Financial Instrument	B or C	4!c	1.8.14	66

Optional Repetitive Subsequence E1 Securities Movement

M	:16R:	Start of Block	SECMOVE			67
M	:22a:	Indicator	F or H	4!c	1.8.8	68
O	:35B:	Identification of the Financial Instrument	[ISIN1!e12!c] [4*35x]		1.8.13	69

Optional Subsequence E1a Financial Instrument Attributes

M	:16R:	Start of Block	FIA			70
O	:94B:	Place/Place of Listing	:4!c/[8c]/4!c[/30x]	PLIS	1.8.20	71
O	:22F:	Indicator/Method of Interest Computation Indicator	:4!c/[8c]/4!c	MICO	1.8.8	72
O	:12a:	Type of Financial Instrument	A,B or C	CLAS	1.8.2	73
O	:11A:	Currency/Currency of Denomination	:4!c//3!a	DENO	1.8.1	74
O	:98A:	Date/Time	:4!c//8!x	4!c	1.8.23	75
O	:90a:	Price/Issue Price	A,B or E	ISSU	1.8.17	76
O	:92a:	Rate	A or K	4!c	1.8.18	77
O	:36B	Quantity of Financial Instrument	:4!c//4!c/15d	4!c	1.8.14	78
M	:16S:	End of Block	FIA			79
End of Subsequence E1a Financial Instrument Attributes						
O	:36B	Quantity of Financial Instrument/Entitled Quantity	:4!c//4!c/15d	ENTL	1.8.14	80
O	:22F:	Indicator/Disposition of Fractions	:4!c/[8c]/4!c	DISF	1.8.8	81
O	:11A:	Currency/Currency Option	:4!c//3!a	OPTN	1.8.1	81
O	:69a:	Period/Trading Period	A,B,C,D,E,F or J	TRDP	1.8.15	83
O	:90a:	Price	A,B, E, F or J	4!c	1.8.17	84
O	:92a:	Rate	A, D, F, J or N	4!c	1.8.18	85
O	:98a:	Date/Time	A,B,C or D	4!c	1.8.23	86
M	:16S:	End of Block	SECMOVE			87
End of Subsequence E1 Securities Movement						
Optional Repetitive Subsequence E2 Cash Movement						
M	:16R:	Start of Block	CASHMOVE			88
M	:22a:	Indicator	H or F		1.8.8	89
O	:97a:	Account/Cash Account	A or E		1.8.22	90
O	:19B:	Amount	:4!c//3!a15d	4!c	1.8.5	91
O	:98a:	Date/Time	A,B, C or E	4!c	1.8.23	92
O	:92a:	Exchange Rate	A, B, F or K	EXCH	1.8.18	93
O	:90a:	Price	A,B,E,F or J	OFFR	1.8.17	94
M	:16S:	End of Block	CASHMOVE			95
End of Subsequence E2 Cash Movement						
O	:70E:	Narrative	:4!c//10*35x		1.8.16	96
M	:16S:	End of Block	CAOPTN			97

End of Sequence E Corporate Action Options

Optional Sequence F Additional Information

M	:16R:	Start of Block	ADDINFO			98
O	:70E:	Narrative	:4!c//10*35x		1.8.16	99
O	:95a:	Party	P, Q or R	4!c	1.8.21	100
M	:16S:	End of Block	ADDINFO			101

End of Sequence F Additional Information

Message flow.

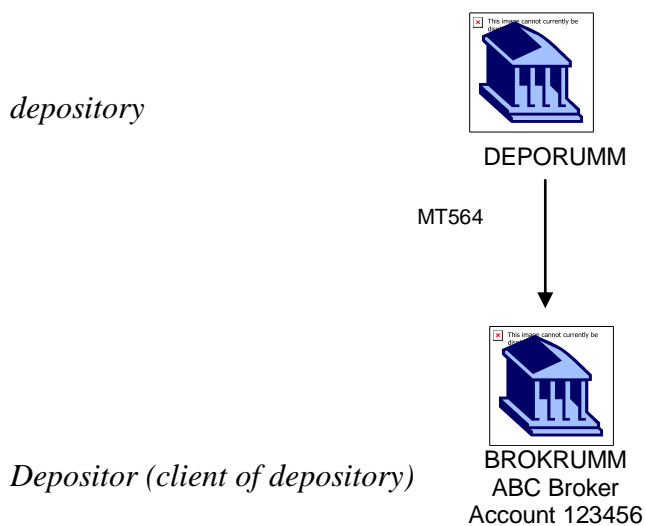

4.2. MT 565 CORPORATE ACTION INSTRUCTION

This message is sent by an account owner to an account servicing organization. This message is sent to the account holder of the account servicing organization. Account holder can be a global custodian which has an account with a local agent (subcustodian), or investment company or broker / dealer that has an account at the custodian.

This message is used to provide the custodian with instructions on how the account owner wishes to proceed with a corporate action event. Instructions include investment decisions regarding the exercise of rights issues, the election of stock or cash when the option is available, and decisions on the conversion or tendering of securities.

This message may also be used to:

- request the cancellation of a previously sent corporate action instruction
- re-send corporate action instruction previously sent
- provide the third-party with a copy of the message.

4.2.1. Format Specifications

Status	Tag	Detailed Field Name	Content/Options	Qualifier	N ^o RUS	N ^o SWIFT User Handbook
Mandatory Sequence A General Information						
M	:16R:	Start of Block	GENL			1
M	:20C:	Sender's Message Reference	:4!c//16x	4!c	1.8.6	2
M	:23G:	Function of the Message	4!c[/4!c]		1.8.9	3
M	:22F:	CA Event Indicator	:4!c/[8c]/4!c	CAEV	1.8.8	4
O	:98a:	Preparation Date/Time	A or C	PREP	1.8.23	5
Optional Repetitive Subsequence A1 Linkages						
M	:16R:	Start of Block	LINK			6
O	:22F:	Indicator/Linkage Type Indicator	:4!c/[8c]/4!c	LINK	1.8.8	7
O	:13a:	Number Identification/Linked Message	A or B	LINK	1.8.3	8
M	:20C:	Linked Message Reference	:4!c//16x	4!c	1.8.7	9
M	:16S:	End of Block	LINK			10

End of Subsequence A1 Linkages						
M	:16S:	End of Block	GENL			11
End of Sequence A General Information						
Mandatory Sequence B Underlying Securities						
M	:16R:	Start of Block	USECU			12
M	:35B:	Identification of the Financial Instrument	[ISIN1!e12!c][4*35x]		1.8.13	13
Optional Subsequence B1 Financial Instrument Attributes						
M	:16R:	Start of Block	FIA			14
O	:94B:	Place/Place of Listing	:4!c/[8c]/4!c[/3 0x]	PLIS	1.8.20	15
O	:22F:	Indicator/Meth od of Interest Computation Indicator	:4!c/[8c]/4!c	MICO	1.8.8	16
O	:12a:	Type of Financial Instrument	A or C	CLAS	1.8.2	17
O	:11A:	Currency/Curr ency of Denomination	:4!c//3!a	DENO	1.8.1	18
O	:98A:	Date/Time	:4!c//8!n	4!c	1.8.23	19
O	:92A:	Rate	:4!c//[N]15d	4!c	1.8.18	20
O	:36B:	Quantity of Financial Instrument	:4!c//4!c/15d	4!c	01.8.14	21
M	:16S:	End of Block	FIA			22
End of Subsequence B1 Financial Instrument Attributes						
Mandatory Repetitive Subsequence B2 Account Information						
M	:16R:	Start of Block	ACCTINFO			23
O	:95a:	Party/Account Owner	P or R	ACOW	1.8.21	24
M	:97a:	Account/Safek eeping Account	:4!c//35x	SAFE	1.8.22	25
O	:94a:	Place/Place of Safekeeping	B,C or F	SAFE	1.8.20	26
O	:93a:	Balance	B or C	4!c	1.8.19	
M	:16S:	End of Block	ACCTINFO			28
End of Subsequence B2 Account Information						
M	:16S:	End of Block	USECU			29
End of Sequence B Underlying Securities						
Optional Sequence C Information about the owner						
M	:16R:	Start of Block	BENODET			30
M	:95a:	Party	P, R, S or V	4!c	1.8.21	31
O	:94C:	Place	:4!c//2!a	4!c	1.8.20	32

O	:36B:	Quantity of financial instrument/Quantity securities owned	:4!c//4!c/15d	OWND	1.8.14	33
O	:22F:	Indicator	:4!c/[8c]/4!c	CETI	1.8.8	34
O	:70E:	Narrative/Declaration Details	:4!c//10*35x	DECL	1.8.16	35
M	:16S:	End of Block	BENODET			36
End of Sequence C Information about the owner						
Optional Sequence D Corporate Action Instruction						
M	:16R:	Start of Block	CAINST			37
M	:13A:	Number Identification/CA Option Number	:4!c//3!c	CAON	1.8.3	38
M	:22a:	Indicator	H or F	4!c	1.8.8	39
O	:11A:	Currency	:4!c//3!a	4!c	1.8.1	40
O	:35B:	Identification of the Financial instrument	[ISIN!e12!c][4*35x]	4!c	1.8.13	41
M	:36a:	Quantity of Financial Instrument	B or C	4!c	1.8.14	42
O	:98a:	Date/Time/Execution Requested Date	A or C	EXRQ	1.8.23	43
O	:92a:	Rate	A or F	4!c	1.8.18	44
O	:90a:	Price	A or B	4!c	1.8.17	45
O	:70E:	Narrative	:4!c//10*35x	4!c	1.8.16	46
M	:16S:	End of Block	CAINST			47
End of Sequence D Corporate Action Instruction						
Optional Repetitive Sequence E Additional information						
M	:16R:	Start of Block	ADDINFO			48
O	:70E:	Narrative	:4!c//10*35x	4!c	1.8.16	49
O	:95a:	Party	P, R or Q	4!c	1.8.21	50
M	:16S:	End of Block	ADDINFO			51
End of Sequence E Additional Information						

Message flow.

depository

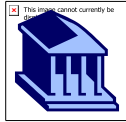

DEPORUMM

MT564



depositor (client of depository)

BROKRUMM
ABC Broker
Account 123456

4.3. MT 566 CORPORATE ACTION CONFIRMATION

This message is sent by an account servicer (account servicing institution) to an account owner or its designated agent. The account servicer may be a local agent (sub-custodian) acting on behalf of their global custodian customer, or a custodian acting on behalf of an investment management institution or a broker/dealer.

This message is used to confirm to the account owner that securities and/or cash have been credited/debited to an account as the result of a corporate action event.

This message may also be used to:

- re-send a corporate action confirmation previously sent (function DUPL)
- provide a third party with a copy of the message (function COPY)
- reverse a previously sent corporate action confirmation (function REVR)

In addition this message can be used to notify about the of automatic claim compensation by the international depository for the transaction “delivery versus payment” settlements or to notify reversal of previously posted amounts of automatic claim compensation.

4.3.1. Format Specifications

Status	Tag	Detaild Field Name	Content/Options	Qualifier	№ RUS	№ SWIFT User Handbook
Mandatory Sequence A General Information						
M	:16R:	Start of Block	GENL			1
M	:20C:	Sender's Message Reference	:4!c//16x	4!c	1.8.6	2
M	:23G:	Function of the Message	4!c/[4!c]	4!c	1.8.9	3
M	:22F:	Corporate Action Event Indicator	:4!c/[8c]/4!c	4!c	1.8.8	4
O	:98a:	Preparation Date/Time	A or C	PREP	1.8.23	5
Optional Repetitive Subsequence A1 Linkages						
M	:16R:	Start of Block	LINK			6
O	:22F:	Indicator/Linkage Type Indicator	:4!c/[8c]/4!c	LINK	1.8.8	7

O	:13a:	Number identificati on/Linked message	A or B	LINK	1.8.3	8
M	:20C:	Linked Message Reference	:4!c//16x	4!c	1.8.7	9
M	:16S:	End of Block	LINK			10
End of Subsequence A1 Linkages						
M	:16S:	End of Block	GENL			11
End of Sequence A General Information						
Mandatory Sequence B Underlying Securities						
M	:16R:	Start of Block	USECU			12
O	:95a:	Party/Acc ount owner	P or R	ACOW	1.8.21	13
M	:97a:	Account/S afekeeping Account	A or C	SAFE	1.8.22	14
O	:94a:	Place/Plac e of Safekeepi ng	B,C or F	SAFE	1.8.20	15
M	:35B:	Identificati on of the Financial Instrument	[ISIN1!e12!c][4 *35x]		1.8.13	16
O	:93a:	Balance	B or C	4!c	1.8.19	26
M	:16S:	End of Block	USECU			27
End of Sequence B Underlying Securities						
Optional Sequence C Corporate Action Details						
M	:16R:	Start of Block	CADETL			28
O	:98a:	Date/Time	A,B,C or E	4!c	1.8.23	29
O	:69a:	Period	A,B,C,D,E,F or J	4!c	1.8.15	30
O	:99A:	Number of days accrued	:4!c//[N]3!n	DAAC	1.8.24	31
O	:92a:	Rate	A,F or K	4!c	1.8.18	32
O	:90a:	Price	A or B	4!c	1.8.17	33
O	:36a:	Quantity of Financial Instrument	B, C or E	4!c	1.8.14	34

O	:13a:	Number Identificati on/Coupo n Number	A or B	COUP	1.8.3	35
O	:17B:	Flag	:4!c//1!a	4!c	1.8.4	36
O	:22F:	Indicator	:4!c/[8c]/4!c	4!c	1.8.8	37
O	:70a:	Narrative	E or G	4!c	1.8.16	38
M	:16S:	End of Block	CADETL			39
End of Sequence C Corporate Action Details						
Mandatory sequence D Corporate Action Confirmation						
M	:16R:	Start of Block	CACONF			40
M	:13A:	Number Identificati on/CA Option Number	!4!c//3!c	CAON	1.8.3	41
M	:22a:	Indicator	F or H	4!c	1.8.8	42
O	:11A:	Currency/ Currency Option	:4!c//3!a	OPTN	1.8.1	43
M	:98a:	Date/Time	A,B,C or E	4!c	1.8.23	44
O	:69a:	Period	A,B,C,D,E, or F	4!c	1.8.15	45
O	:92a:	Rate	A,F or J	4!c	1.8.18	46
O	:90a:	Price	A or B	4!c	1.8.17	47
O	:94B:	Place/Plac e of Trade	:4!c/[8c]/4!c[/30 x]	TRAD	1.8.20	48
Optional Repetitive Subsequence D1 Securities Movement						
M	:16R:	Start of Block	SECMOVE			49
M	:22F:	Indicator	F or H	4!c	1.8.8	50
O	:35B:	Identificati on of the Financial Instrument	[ISIN1!e12!c] [4*35x]		1.8.13	51
Optional Subsequence D1a Financial Instrument Attributes						
M	:16R:	Start of Block	FIA			52
O	:94B:	Place/Plac e of Listing	:4!c/[8c]/4!c[/30 x]	PLIS	1.8.20	53
O	:22F:	Indicator/ Method of Interest Computati on	:4!c/[8c]/4!c	MICO	1.8.8	54
O	:12a:	Type of Financial Instrument	A or C	4!c CLAS	1.8.2	55

O	:11A:	Currency/ Currency of Denomina tion	:4!c//3!a	DENO	1.8.1	56
O	:98A:	Date/Time	:4!c//8!n	4!c	1.8.23	57
O	:90a:	Price/Issue Price	A or B	ISSU	1.8.17	58
O	:92a:	Rate	A or K	4!c	1.8.18	59
O	:36B:	Quantity of Financial instrument	:4!c//4!c/15d	4!c	1.8.14	60
M	:16S:	End of Block	FIA			61
End of Subsequence D1a Financial Instrument Attributes						
O	:36B	Quantity of Financial Instrument	:4!c//4!c/15d	PSTA	1.8.14	62
O	:94a:	Place/Plac e of Safekeepi ng	B,C or F	SAFE	1.8.20	63
O	:22F:	Indicator/ Dispositio n of Fractions	:4!c//[8c]/4!c	DISF	1.8.8	64
O	:11A:	Currency/ Currency Option	:4!c//3!a	OPTN	1.8.1	65
O	:90a:	Price	A, B, F or J	4!c	1.8.17	66
O	:92a:	Rate	A, D, F, J, Lor N	4!c	1.8.18	67
O	:98a:	Date/Time	A,B,C or E	4!c	1.8.23	68
Optional Repetitive Subsequence D1b Receiver/Deliverer						
M	:16R:	Start of Block	RECDEL			69
O	:95a:	Party	C,P,R,Q or S	4!c	1.8.21	70
O	:97A:	Account/S afekeeping Account	:4!c//35x	SAFE	1.8.22	71
M	:20C:	Reference/ Processing Reference	:4!c//16x	PROC	1.8.7	72
O	:70E:	Narrative	:4!c//10*35x	PACO	1.8.16	73
M	:16S:	End of Block	RECDEL			74
End of Subsequence D1b Receiver/Deliverer						
M	:16S:	End of Block	SECMOVE			75

End of Subsequence D1 Securities Movement						
Optional Repetitive Subsequence D2 Cash Movement						
M	:16R:	Start of Block	CASHMOVE			76
M	:22a:	Indicator	H or F	4!c	1.8.8	77
O	:97a:	Account	A or E	4!c	1.8.22	78
Optional Repetitive Subsequence D2a Cash Parties						
M	:16R:	Start of Block	CASHPRTYE			79
M	:95a:	Party	P,R,Q or S		1.8.21	80
O	:97a:	Account/C ash Account	A or E	CASH	1.8.22	81
M	:20C:	Reference/ Processing Reference	:4!c//16x	PROC	1.8.7	82
O	:70E:	Narrative	:4!c//10*35x	PACO	1.8.16	83
M	:16S:	End of Block	CASHPRTYE			84
End of Subsequence D2a Cash Parties						
M	:19A	Amount	:4!c//[N]3!a15d	4!c	1.8.5	85
O	:98a:	Date/Time	A, C or E	4!c	1.8.23	86
O	:92B:	Exchange Rate	:4!c//3!a/3!a/15d	EXCH	1.8.18	87
O	:90a:	Price	A,B,F or J	OFFR	1.8.17	88
Optional Subsequence D2b Tax Voucher Details – the subsequence is not applicable for Russian securities						
M	:16R:	Start of Block	TAXVODET			89
M	:20C:	Tax Voucher Reference	:4!c//16x	TAVO	1.8.7	90
O	:98a:	Date/Time	A or C	4!c	1.8.23	91
M	:16S:	End of Block	TAXVODET			92
End of Subsequence D2b Tax Voucher Details						
M	:16S:	End of Block	CASHMOVE			93
End of Subsequence D2 Cash Movement						
M	:16S:	End of Block	CACONF			94
End of Sequence D Corporate Action Confirmation						
Optional Sequence E Additional Information						
M	:16R:	Start of Block	ADDINFO			95
O	:70E:	Narrative	:4!c//10*35x	4!c	1.8.16	96
O	:95a:	Party	P,R or Q	4!c	1.8.21	97
M	:16S:	End of Block	ADDINFO			98
End of Sequence E Additional Information						

Message flow.

depository

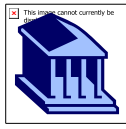

DEPORUMM

MT564



depositor (client of depository)

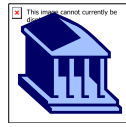

BROKRUMM
ABC Broker
Account 123456

4.4. MT 567 CORPORATE ACTION STATUS AND PROCESSING ADVICE

This message is sent by an account servicer (account servicing institution) to an account owner or its designated agent. The account servicer may be a local agent (sub-custodian) acting on behalf of their global custodian customer, or a custodian acting on behalf of an investment management institution or a broker/dealer.

This message is used to advise the status or a change in status of a corporate action-related transaction previously instructed or executed on behalf of the account owner.

This will include the acknowledgement/rejection of a corporate action instruction or the acknowledgement/rejection of a request to cancel an outstanding instruction. It also may also be used to provide a reason as to why a corporate action event has not been completed by the announced payment dates.

This message may also be used to:

- re-send a corporate action status previously sent
- provide a third party with a copy of the message

4.4.1. Format Specifications

Status	Tag	Detaild Field Name	Content/Options	Qualifier	Nº RUS	Nº SWIFT User Handbook
Mandatory Sequence A General Information						
M	:16R:	Start of Block	GENL			1
M	:20C:	Sender's Message Reference	:4!c//16x	4!c	1.8.6	2
M	:23G:	Function of the Message	4!c[/4!c]		1.8.9	3
M	:22F:	Corporate Action Event Indicator	:4!c/[8c]/4!c	CAEV	1.8.8	4
O	:98a:	Preparation Date/Time	A or C	PREP	1.8.23	5
M	:16R:	Start of Block				6
O	:13a:	Number identification/ Linked message	A or B	LINK	1.8.3	7
M	:20C:	Linked Message Reference	:4!c//16x	4!c	1.8.7	8
M	:16S:	End of Block	LINK			9
End of Subsequence A1 Linkages						
Mandatory Subsequence A2 Status						
M	:16R:	Start of Block	STAT			

M	:25D:	Status Code	:4!c/[8c]/4!c	4!c	1.8.11	11
Mandatory Subsequence A2a Reason						
M	:16R:	Start of Block	REAS			12
M	:24B:	Reason Code	:4!c/[8c]/4!c	4!c	1.8.10	13
O	:70D:	Narrative	:4!c//6*35x	REAS	1.8.16	14
M	:16S:	End of Block	REAS			15
End of Sequence A General information						
Optional Sequence B Corporate Action Details						
M	:16R:	Start of Block	CADETL			18
M	:13A:	Number identification/ CA Option Number	4!c//3!c	CAON	1.8.3	19
O	:22a:	CA Option Code Indicator	F or H	CAOP	1.8.8	20
O	:95a:	Party/Account Owner	P or R	ACOW	1.8.21	21
O	:97a:	Account	A or E	4!c	1.8.22	22
O	:94a:	Place/Place of Safekeeping	B, C or F	SAFE	1.8.20	23
O	:35B:	Identification of the Financial instrument	[ISIN!e12!c][4 *35x]	4!c	1.8.13	24
O	:36B:	Quantity of Financial Instrument	:4!c//4!c/15d	4!c	1.8.14	25
O	:19A:	Amount	:4!c//[N]3!a15 d		1.8.5	26
O	:93B:	Balance	:4!c//[8c]/4!c[N]15d		1.8.19	27
M	:16S:	End of Block	CADETL			28
End of Sequence B Corporate Action Details						
Optional sequence C Additional information						
M	:16R:	Start of Block	ADDINFO			29
O	:70E:	Narrative	:4!c//10*35x	4!c	1.8.16	30
O	:95a:	Party	P,R or Q	4!c	1.8.21	31
M	:16S:	End of Block	ADDINFO			32
End of Sequence E Additional Information						

Message flow.

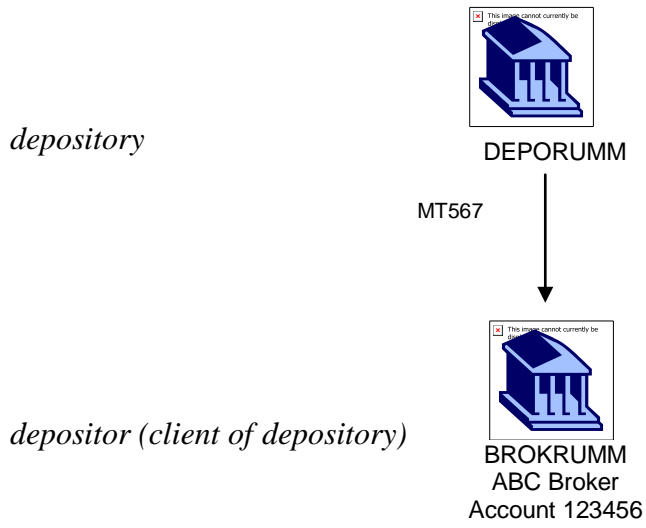

4.5. MT 568 CORPORATE ACTION NARRATIVE

This message is sent by an account owner or his account servicer (account servicing institution)

The account owner may be a global custodian with an account at the local agent (subcustodian), or a investment company or a broker/dealer.

The account servicer may be a local agent (sub-custodian) acting on behalf of their global custodian customer, or a custodian acting on behalf of an investment management institution or a broker/dealer.

This message might be sent to both sides.

This message is used send complex instructions or information in body text related to the corporate event.

This message may also be used to:

- cancel previously sent message on the corporate action in body text

This message may be sent to:

- resending of the previously sent message on the corporate action (function – DUPL)
- rendering the copy of the preciously sent message on the corporate action to a third party (function – COPY)

4.5.1. Format Specifications

Status	Tag	Detaild Field Name	Content/Options	Qualifier	№ RUS	№ SWIFT User Handbook
Mandatory Sequence A General Information						
M	:16R:	Start of Block	GENL			1
O	:28E:	Page Number/Continuation Indicator	:5n/4!c		1.8.12	2
M	:20C:	Reference	:4!c//16x	4!c	1.8.6	3
M	:23G:	Function of the Message	4!c[/4!c]	4!c	1.8.9	4
M	:22F:	Corporate Action Event Indicator	:4!c/[8c]/4!c	CAEV	1.8.8	5
O	:98a:	Preparation Date/Time	A or C	PREP	1.8.23	6
Optional Repetitive Subsequence A1 Linkages						
M	:16R:	Start of Block	LINK			7
O	:22F:	Indicator/Linkage Type Indicator	:4!c/[8c]/4!c	LINK	1.8.8	8

O	:13a:	Number Identificatio n/Linked message	A or B	LINK		9
M	:20C:	Linked Message Reference	:4!c//16x	4!c	1.8.7	10
M	:16S:	End of Block	LINK			11
End of Subsequence A1 Linkages						
M	:16S:	End of Block	GENL			12
End of Sequence A General Information						
Mandatory Sequence B Underlying Securities						
M	:16R:	Start of Block	USECU			13
O	:95a:	Party/Accou nt Owner	P or R	ACOW	1.8.21	14
M	:97a:	Account/Saf ekeeping Account	A or C	SAFE	1.8.22	15
O	:94a:	Place/Place of Safekeeping	B,C or F	SAFE	1.8.20	16
O	:35B:	Identificatio n of the Financial Instrument	[ISIN1!e12!c]	[4*35x]	1.8.13	17
Optional Sub-Sequence B1 Financial Instrument Attributes						
M	:16R:	Start of Block	FIA			18
O	:94B:	Place/Place of Listing	:4!c/[8c]/4!c[3 0x]	PLIS	1.8.20	19
O	:22F:	Indicator/M ethod of interst Computatio n Indicator	:4!c/[8c]/4!c	MICO	1.8.8	20
O	:12a:	Type of Financial instrument	A or C	4!c CLAS	1.8.2	21
O	:11A:	Currency/ Currency of Denominati on	:4!c//3!a	DENO	1.8.1	22
O	:98A:	Date/Time	:4!c//8!n	4!c	1.8.23	23
O	:90a:	Price/issue price	A or B	ISSU	1.8.17	24
O	:36B:	Quantity of Financial instrument	:4!c//4!c/15d	4!c	1.8.14	25

M	:16S:	End of Block	FIA			26
End of Sub-Sequence B1 Financial instrument Attributes						
O	:93a:	Balance	B or C	4!c	1.8.19	27
M	:16S:	End of Block	USECU			28
End of Sequence B Underlying Securities						
Optional Sequence C Additional information						
M	:16R:	Start of Block	ADDINFO			29
M	:70a:	Narrative	E or F	4!c	1.8.16	30
O	:95a:	Party	P,R or Q	4!c	1.8.21	31
M	:16S:	End of Block	ADDINFO			32
End of Sequence C Additional Information						

Message flow.

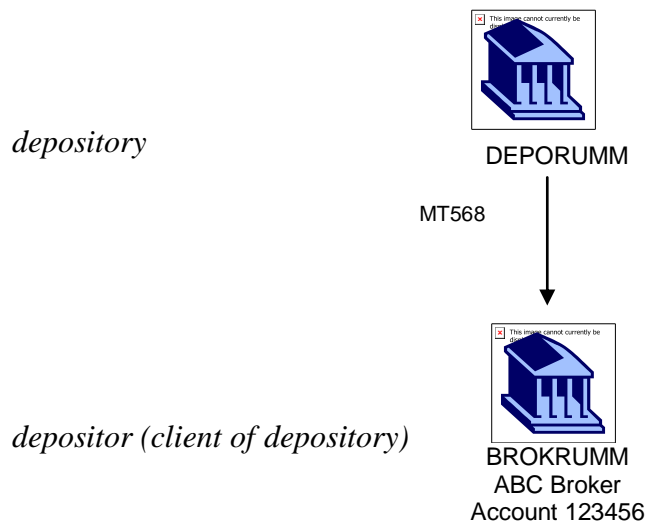

5. CORPORATE ACTION MESSAGES EXAMPLES

5.1.1. Example 1 Corporate action event type - Repurchase of shares according to the articles 75-76 208-Federal Law (corporate action event indicator – BIDS)

Definition

The offer of the issuer to its shareholders to repurchase its shares or other securities convertible into shares. The purpose of this proposal - reducing the number of shares outstanding.

In accordance with this recommendation the function is also used when a shareholder uses its right to demand redemption of their shares by virtue of Art. 75-76 Federal Law of 24.11.1995 № 208-FZ "On Joint Stock Companies".

Initial terms:

-Issuer – OAO “Fortum” (former OAO “TGK-10”)

Details of issue:

common stock

ISIN RU000A0F61T7

State registration date May 14th 2009

AGM date, which resulted in a claim of shares redemption from shareholders who voted against/did not take part at all per item of the AGM agenda "Approval of the Company's new version Charter" – 15.04.2009

date as of which the list of persons entitled shares redemption – 06.03.2009

Details of securities repurchase:

Price – 69,7106 rubles

Period of filling application – 45 days – from 15.04.2009 to 01.06.2009

Payment currency – Rubles

Due date – 30 days – not late than 01.07.2009

Date of transfer – within three working days of receiving a set of documents from issuer

Restrictions:

i) if the total amount of shares offered for redemption of OAO "TGC-10" will exceed 10% of net assets on the date taken the decision to approve the Company's new edition Charter, the shares will be redeemed in proportion to the stated claims (determination period- 5 days after the receipt of applications)

ii) blocking of securities on safekeeping account/separate account of the shareholder is obligatory

Additional conditions:

Safekeeping account number: 123456

Quantity of securities on the date of the listing of registered persons: 1,500

Deadline for transferring client instructions: 15.05.2009 to depository

Stages

1. Informing the account owner on the outcome of the AGM where it was decided that the account owners may claim repurchase securities. Depository notifies its client by MT564/BIDS/NEWM/COMP

MT564/BIDS indicating the status of the corporate action COMP (full details)

Additional MT568 is sent to the account owner describing the details of the corporate action in the text format indicating the links to MT564 (IVANIV0904161458).

MT564 – Corporate action notification

Corporate action reference CATGK10160409
Sender's reference – IVANIV0904161001

Sender of MT564 DEPORUMM
Receiver of MT564 BROCKRUMM

Message structure:

:16R:GENL
:20C::CORP//CATGK10160409
:20C::SEME//IVANIV0904161001
:23G:NEWM
:22F::CAEV//BIDS
:22F::CAMV//VOLU
:25D::PROC//COMP
:16R:LINK
:13A::LINK//568
:20C::PREV//IVANIV0904161459
:16S:LINK
:16S:GENL
:16R:USECU
:35B:ISIN RU000A0F61T7
TGK-10, AOI or JSC TGK10 ORD SHS
:16R:ACCTINFO
:97A::SAFE//123456
:93B::ELIG//UNIT/1500,
:16S:ACCTINFO
:97A::SAFE//123456
:93B::ELIG//UNIT/1500,
:16S:ACCTINFO
:16S:USECU
:16R:CADETL
:98C::MEET//20090415000000
:98A::RDTE//20090306
:16S:CADETL
:16R:CAOPTN
:13A::CAON//001
:22F::CAOP//CASH
:17B::DFLT//N
:98C::MKDT//20090601170000
:98C::RDDT//20090515150000
:69A::PWAL//20090415/20090601
:90B::OFFR//ACTU/RUB69,7106
:16S:CAOPTN
:16R:CAOPTN
:13A::CAON//002

:22F::CAOP//NOAC
:17B::DFLT//Y
:16S:CAOPTN
:16R:ADDINFO
:70E::ADTX//SOOBqENIE BUDET PRODOLJENO V
MT568 S KODOM CATGK10160409
SWIFT WILL BE CONTINUED ON MT568
WITH CORP CATGK10160409
:16S:ADDINFO

MT568 – Corporate action narrative

Corporate action reference CATGK10160409
Sender's reference – IVANIV0904161459

Sender of MT568 DEPORUMM
Receiver of MT568 BROCKRUMM

Message structure:

:16R:GENL
:20C::CORP//CATGK10160409
:20C::SEME//IVANIV0904161459
:23G:NEWM
:22F::CAEV//BIDS
:16R:LINK
:13A::LINK//564
:20C::PREV//IVANIV0904161001
:16S:LINK
:16S:GENL
:16R:USECU
:97A::SAFE//123456
:35B:ISIN RU000A0F61T7
TGK-10, AOI or JSC TGK10 ORD SHS
:93B::ELIG//UNIT/1500,
:16S:USECU
:16R:ADDINFO
:70F::ADTX//NASTOaqIM SOOBqAEM, cTO 15 APRELa 2009 GODA OBqEE
SOBRANIE AKCIONEROV OAO "TGK-10" (ISIN RU000A0F61T7)
UTVERDILO NOVUu VERSIu USTAVA KOMPANII.
V SOOTVETSTVII SO ST. 75 FZ "OB AKCIONERNYH OBqESTVAH"
VLADELXCY OBYKNOVENNYH AKCIi TGK-10, KOTORYE GOLOSOVANII
PROTIV ILI NE PRINIMALI UcASTIa V GOLOSOVANII ILI NE
GOLOSOVALI PO PUNKTU POVESTKI OB UTVERJDENII NOVOi VERSII
USTAVA KOMPANII, IMEuT PRAVO TREBOVATX OT eMITENTA
VYKUPITX VSE ILI cASTX AKCIi V OBxEME, NE PREVYQAuqEM
OSTATKI NA ScETAH AKCIONERA PO SOSTOaNu NA 6 MARTA 2009
GODA, PO CENE 67,7106 RUB. ZA AKCIu.
ESLI OBqEE KOLICESTVO AKCIi PREDxaVLENNYH K VYKUPU
PREVYSIT 10p OBYKNOVENNYH AKCIi NAHODaqIHSa V OBRAqENII
NA DATU PRINaTIa REQENIa (15 APRELa 2009) TGK-10 VYKUPIT

AKCII V PROPORCII K KOLICESTVU AKCIi PREDxaVLENNYH K
VYKUPU

or

:70F::ADTX//PLEASE BE ADVISED THAT ON APRIL 15, 2009 THE AGM OF JSC
TGK10 (ISINRU000A0F61T7) APPROVED A NEW WORDING OF CHARTER OF
COMPANY.

ACCORDING TO THE ARTICLE 75 OF THE FEDERAL LAW ON JOINT STOCK
COMPANIES THE OWNERS OF TGK10 ORDINARY SHARES WHO VOTED
AGAINST OR DID NOT TAKE PART IN THE VOTING AT ALL PER ITEM OF THE
AGM AGENDA, RELATED TO A NEW WORDING OF CHARTER OF THE
COMPANY, OBTAIN THE RIGHT TO DEMAND FROM THE ISSUER TO REDEEM
ALL OR PART OF ITS SHARES DUE TO BOOK HOLDINGS ON MARCH 06, 2009
AT THE REPURCHASE PRICE RUB 69.7106 FOR ONE ORD. SHARE.

IF THE TOTAL AMOUNT OF SHARES OFFERED FOR REDEMPTION WILL
EXCEED 10 PERCENT OF NET ASSETS ON THE DATE OF TAKEN THE DECISION
(APRIL 15, 2009), TGK10 SHALL REDEEM THE SHARES FROM ALL
SHAREHOLDERS WHO TENDERED THEIR OFFER LETTERS ON A PRO RATA
BASIS.

PLEASE BE AWARE THAT THIS CORPORATE ACTION IS VOLUNTARY.
IF SHAREHOLDER TO ADVISE ON THEIR INTENTION TO TENDER THE SHARES
FOR BUYBACK, WE HAVE TO ENSURE TRANSFER OF SHARES TO DEPO
ACCOUNT DEDICATED FOR BLOCKED SECURITIES. IN CASE OF ACCEPTANCE
OF THE APPLICATION, WHILE TGK10 IN ITS TURN SHALL PAY THE SHARES
AT THE ABOVE MENTIONED PRICE BEFORE JULY 01, 2009.

PLS. BE ADVISED THAT RUB CASH PROCEEDS MAY BE A SUBJECT TO
WITHHOLDING TAX ON CAPITAL GAINS.

FOR ADDITIONAL INFORMATION PLEASE CONTACT OUR GROUP E-MAIL
:16S:ADDINFO

**2. Sending a reminder to the clients which have not sent the instructions for
corporate actions – Corporate action notification MT564/BIDS/ indicating function
RMRD (reminder)**

MT564 – Corporate action notification

Corporate action reference CATGK10160409

Sender's reference – IVANIV090514140922

Sender of MT564 DEPORUMM

Receiver of MT564 BROCKRUMM

Message structure:

:16R:GENL

:20C::CORP//CATGK10160409

:20C::SEME//IVANIV0905140922

:23G:RMDR

:22F::CAEV//BIDS

:22F::CAMV//VOLU

:25D::PROC//COMP

:16R:LINK

:20C::PREV//IVANIV0904161001
:16S:LINK
:16S:GENL
:16R:USECU
:35B:ISIN RU000A0F61T7
FORTUM, AOI
:16R:ACCTINFO
:97A::SAFE//123456
:93B::ELIG//UNIT/1500,
:16S:ACCTINFO
:16S:USECU
:16R:CADETL
:98C::MEET//20090415000000
:98A::RDTE//20090306
:16S:CADETL
:16R:CAOPTN
:13A::CAON//001
:22F::CAOP//CASH
:17B::DFLT//N
:98C::MKDT//20090601170000
:98C::RDDT//20090515140000
:69A::PWAL//20090415/20090601
:90B::OFFR//ACTU/RUB69,7106
:16S:CAOPTN
:16R:CAOPTN
:13A::CAON//002
:22F::CAOP//NOAC
:17B::DFLT//Y
:16S:CAOPTN

or JSC FORTUM (JSC TGK10) ORD SHS

3. The client sends to the depository instructions regarding corporate action (MT565) indicating quantity of the securities under the instruction :36B::QINS//UNIT/900,

MT565 – Corporate Action Instruction

Corporate action reference CATGK10160409
Sender's reference – IVANIV0904281458

Sender of MT565 DEPORUMM
Receiver of MT565 BROCKRUMM

Message structure:

:16R:GENL
:20C::CORP//CATGK10160409
:20C::SEME//BROK0904281458
:23G:NEWM
:22F::CAEV//BIDS
:16R:LINK

:13A::LINK//564
:20C::RELA//IVANIV0904161001
or
:20C::RELA//IVANIV0905140922
:16S:LINK
:16S:GENL
:16R:USECU
:35B:ISIN RU000A0F61T7
FORTUM, AOI or JSC FORTUM (JSC TGK10)
:16R:ACCTINFO
:97A::SAFE//123456
:93B::ELIG//UNIT/1500,
:16S:ACCTINFO
:16S:USECU
:16R:CAINST
:13A::CAON//001
:22H::CAOP//CASH
:92A::OFFR//69,7106
:36B::QINS//UNIT/1000,
:16S:CAINST

4. On receipt of the instruction from the client the depository sends MT567 which confirms the instruction receipt (MT565) indicating the quantity of the securities under the instruction :93B::INBA//UNIT/1000,

MT567 – Corporate Action Status and Processing Advice

Corporate action reference CATGK10160409
Sender's reference – IVANIV0904161460

Sender of MT567 DEPORUMM
Receiver of MT567 BROCKRUMM

Message structure:

:16R:GENL
:20C::CORP//CATGK10160409
:20C::SEME//IVANIV0904161460
:23G:NEWM
:22F::CAEV//BIDS
:98A::PREP//20090428
:16R:LINK
:13A::LINK//564
:20C::PREV//IVANIV0904270922
:16S:LINK
:16R:LINK
:13A::LINK//565
:20C::RELA//BROK0904281458
:16S:LINK
:16R:STAT
:25D::IPRC//PACK

:16S:STAT
:16S:GENL
:16R:CADETL
:13A::CAON//001
:97A::SAFE//123456
:35B:ISIN RU000A0F61T7
'FORTUM, AOI or JSC FORTUM (JSC TGK10)
:93B::ELIG//UNIT/1500,
:93B::INBA//UNIT/1000,
:16S:CADETL

5. Sending the issuer documentation and blocking the shares in depository. Additional client may receive MT544/546 indicating that the shares are blocked on the safekeeping account (transferring securities between the safekeeping accounts).

6. When announcing the rate of the redemption of shares – 0,9, the owners receive MT564/BIDS/ indicating function REPL (replacement)

MT564 – Corporate Action Notificatio

Corporate action reference CATGK10160409
Sender's reference – IVANIV0904161458

Sender of MT564 DEPORUMM
Receiver of MT564 BROCKRUMM

Message structure:

:16R:GENL
:20C::CORP//CATGK10160409
:20C::SEME//IVANIV0905140922
:23G:REPL
:22F::CAEV//BIDS
:22F::CAMV//VOLU
:25D::PROC//COMP
:16R:LINK
:20C::PREV//IVANIV0904161001
:16S:LINK
:16S:GENL
:16R:USECU
:35B:ISIN RU000A0F61T7
'FORTUM, AOI or JSC FORTUM (JSC TGK10) ORD SHS
:16R:ACCTINFO
:97A::SAFE//123456
:93B::ELIG//UNIT/1500,
:16S:ACCTINFO
:16S:USECU
:16R:CADETL
:98C::MEET//20090415000000
:98A::RDTE//20090306
:16S:CADETL

:16R:CAOPTN
:13A::CAON//001
:22F::CAOP//CASH
:17B::DFLT//N
:98C::MKDT//20090601170000
:98C::RDDT//20090515140000
:69A::PWAL//20090415/20090601
:92A::PROR//0,9
:90B::OFFR//ACTU/RUB69,7106
:16S:CAOPTN
:16R:CAOPTN
:13A::CAON//002
:22F::CAOP//NOAC
:17B::DFLT//Y
:16S:CAOPTN

7. Sending confirmation on corporate action based on withdrawal of securities and crediting of money based on repurchase

Two confirmations on corporate action might be sent on one corporate action:

- as confirmation of crediting of funds (in the absence of information regarding withdrawal of securities in the registrar on the payment date)
- then as confirmation of withdrawal of securities (after receiving information from the registrar on withdrawal of securities)

or

- confirmation after receiving information about transferring of funds and information from the registrar on withdrawal of the securities.

Option 1 - two confirmation of corporate action

a. Control of transferring funds (depending on the location specified in the Statement of account), sending confirmation on the corporate action - confirmation of crediting of funds (MT566/BIDS/CRED).

MT566 – Confirmation of corporate action

Corporate action reference CATGK10160409

Sender's reference – IVANIV090416145C

Sender of MT566 DEPORUMM

Receiver of MT566 BROCKRUMM

Message structure:

:16R:GENL
:20C::CORP//CATGK10160409
:20C::SEME//IVANIV0904161458
:23G:NEWM
:22F::CAEV//BIDS
:98A::PREP//20090701
:16R:LINK
:13A::LINK//564
:20C::PREV//IVANIV0905140922
:16S:LINK

:16S:GENL
:16R:USECU
:97A::SAFE//123456
:35B:ISIN RU000A0F61T7
JSC FORTUM (JSC TGK10)
:93B::CONB//UNIT/900,
:16S:USECU
:16R:CADETL
:98A::PAYD//20090701
:16S:CADETL
:16R:CACONF
:13A::CAON//001
:22F::CAOP//CASH
:16R:SECMOVE
:22H::CRDB//DEBT
:35B:ISIN RU000A0F61T7
JSC FORTUM (JSC TGK10)
:36B::PSTA//UNIT/900,
:98A::POST//20090703
:16S:SECMOVE
:16R:CASHMOVE
:22H::CRDB//CRED
:19B:GRSS//RUB62739,54
:19B:WITL//RUB0,
:19B:PSTA//RUB62739,54
:98A::POST//20090623
:16S:CASHMOVE
:16S:CACONF
:16R:ADDINFO
:70E::PACO//SHOULD YOU HAVE ANY QUESTIONS
PLEASE CONTACT OUR GROUP
E-MAIL ADDRESS XXXXXX (AT)XXXXXX
BEST REGARDS
CORPORATE ACTIONS
:16S:ADDINFO

b. Withdrawal of securities in favor of "Fortum" within 3 working days after obtaining the appropriate set of documents, sending MT566/DEBT

MT566 – Corporate Action Confirmation

Corporate action reference CATGK1060409

Sender's reference – IVANIV0904161498

Sender of MT566 DEPORUMM

Receiver of MT566 BROCKRUMM

Message structure:

:16R:GENL
:20C::CORP//CATGK10160409

:20C::SEME//IVANIV0904161498
:23G:NEWM
:22F::CAEV//BIDS
:98A::PREP//20090701
:16R:LINK
:13A::LINK//564
:20C::PREV//IVANIV0905140922
:16S:LINK
:16S:GENL
:16R:USECU
:97A::SAFE//123456
:35B:ISIN RU000A0F61T7
'FORTUM, AOI or JSC
FORTUM (JSC TGK10)
:93B::CONB//UNIT/900,
:16S:USECU
:16R:CADETL
:98A::PAYD//20090701
:16S:CADETL
:16R:CACONF
:13A::CAON//001
:22F::CAOP//CASH
:16R:CASHMOVE
:22H::CRDB//CRED
:19B::GRSS//RUB62739,54
:19B::WITL//RUB0,
:19B::NETT//RUB62739,54
:98A::POST//20090701
:16S:CASHMOVE
:16R:SECMOVE
:22H::CRDB//DEBT
:35B:ISIN RU000A0F61T7
'FORTUM, AOI or JSC
FORTUM (JSC TGK10)
:36B::PSTA//UNIT/900,
:98A::POST//20090703
:16S:SECMOVE
:16S:CACONF
:16R:ADDINFO
:70E::PACO//SHOULD YOU HAVE ANY
QUESTIONS PLEASE CONTACT OUR
GROUP E-MAIL XXXXX (AT) XXXX
BEST REGARDS,
CORPORATE ACTIONS
:16S:ADDINFO

Version 2 – one confirmation (after receiving of information from the registrar on withdrawal of securities)

MT566 – Confirmation of corporate action

Corporate action reference CATGK10160409
Sender's reference – IVANIV09041614CS

Sender of MT566 DEPORUMM
Receiver of MT566 BROCKRUMM

Message structure:

:16R:GENL
:20C::CORP//CATGK10160409
:20C::SEME//IVANIV09041614CS
:23G:NEWM
:22F::CAEV//BIDS
:98A::PREP//20090703
:16R:LINK
:13A::LINK//564
:20C::PREV//IVANIV0905140922
:16S:LINK
:16S:GENL
:16R:USECU
:97A::SAFE//123456
:35B:ISIN RU000A0F61T7
JSC FORTUM (JSC TGK10)
:93B::CONB//UNIT/900,
:16S:USECU
:16R:CADETL
:98A::EFFD//20090701
:16S:CADETL
:16R:CACONF
:13A::CAON//001
:22F::CAOP//CASH
:16R:SECMOVE
:22H::CRDB//DEBT
:35B:ISIN RU000A0F61T7
JSC FORTUM (JSC TGK10)
:36B::PSTA//UNIT/900,
:98A::POST//20090703
:16S:SECMOVE
:16R:CASHMOVE
:22H::CRDB//CRED
:19B:GRSS//RUB62739,54
:19B:WITL//RUB0,
:19B:PSTA//RUB62739,54
:98A::POST//20090623
:98A::PAYD//20090623
:16S:CASHMOVE
:16S:CACONF
:16R:ADDINFO
:70E::PACO//SHOULD YOU HAVE ANY QUESTIONS
PLEASE CONTACT OUR GROUP
E-MAIL ADDRESS XXXXXX (AT)XXXXXX
BEST REGARDS

**5.1.2. Example 2a. Corporate action event type - Bankruptcy
(corporate action event indicator – BRUP)**

MAIN TERMS OF CORPORATE ACTION

Definition

The legal status of a company unable to pay off its creditors. Bankruptcy usually involves a legal judgment. Securities thus can default.

Initial terms:

-Issuer – uKOS NK, OAO

Details of issue:

common stock

ISIN RU0009054449

National state registration number 1-02-00198-A

state registration date July 22nd 2003

face value – 0,004 rubles

Additional details on corporate action

Initiation of a bankruptcy case date – March 27th 2006

Initiation of bankruptcy proceeding date – August 1st 2006

Termination of activity because of liquidation date – November 21st 2007

Additional terms:

Safekeeping account number: 123456

Cash account number: 01234567890123456789

Quantity of securities on the date of the listing of registered persons: 289 730.00

Obtaining information from any source about initiating a bankruptcy proceedings of the issuer.

At this stage it is recommended to send a client MT564/BRUP/NEWM/PREU

This is an example of Corporate Action Notification sent by the depository (BIC DEPORUMM) to the account owner ABC BROKER (BIC BROKRUMM) and contains information on corporate action on safekeeping account 123456 on OAO “uKOS NK” securities.

The rules of financial instrument’s indication are defined in section 1.8.5 of this document.

Sateges:

1. Notification is formed by depository and contains preliminary information on details of corporate action obtained from mass media – initiation of OAO “uKOS NK” bankruptcy proceedings (MT564/BRUP/NEWM/PREU).

Date and time of the notification – June, 30th 2009, 18:30:51

MT564 – Corporate Action Notification

Corporate action reference BRUP09063007

Sender’s reference – BRUP09063007001

Sender of MT564 DEPORUMM
Receiver of MT564 BROCKRUMM
Message structure:

:16R:GENL
:20C::CORP//BRUP09063007
:20C::SEME//BRUP09063007001
:23G:NEWM
:22F::CAEV//BRUP
:22F::CAMV//MAND
:98C::PREP//20090630183051
:25D::PROC//PREU
:16S:GENL
:16R:USECU
:35B:ISIN RU0009054449
'uKOS, AOI or YUKOS, COMMON
:16R:ACCTINFO
:97A::SAFE//123456
:94B::SAFE//SHHE/REGISTRAR
:16S:ACCTINFO
:16S:USECU
:16R:CADETL
:98B::ANOU//OPEN
:98B::EFFD//OPEN
:16S:CADETL
:16R:ADDINFO
:70E::ADTX//NASTOaqIM SOOBqAEM, cTO SOGLASNO
INFORMACII POLUcENNOi IZ
SREDSTV MASSOVOi INFORMACII,
MOSKOVSKIi ARBITRAJNYi SUD
INICIIROVAL PROCEDURU BANKROTSTVA
V OTNOQENII eMITENTA
or
:70E::ADTX//PLEASE BE ADVISED THAT ACCORDING TO
MASS-MEDIA SOURCES THE ARBITRATION
COURT OF MOSCOW HAS INITIATED THE
BANKRUPTCY PROCEDURE FOR THE ISSUER
:16S:ADDINFO

2. Receiving/publishing by the issuer a substantial fact of “Commencement of bankruptcy proceedings” and sending by depository of the notification on corporate action with confirmed information, replacing previous notification (MT564/BRUP/REPL/PREC).

MT564/BRUP/PREC (if notification contains large bulk of data additionally to MT564 it is possible to send MT568)

This is an example of Corporate Action Notification sent by the depository (BIC DEPORUMM) to the account owner ABC BROKER (BIC BROKRUMM) and contains

information on corporate action on safekeeping account 123456 on OAO “uKOS NK” securities.

The rules of financial instrument’s indication are defined in section 1.8.13 of this document.

Notification is formed by the depository and contains information which is received from the Issuer on details of corporate action – initiation of OAO “uKOS NK” bankruptcy proceedings.

Notification formation date and time – June 30th 2009, 18:55:16

MT564 – Corporate Action Notification

Corporate action reference BRUP09063007

Sender’s reference – BRUP09063007002

Sender of MT564 DEPORUMM

Receiver of MT564 BROCKRUMM

Message structure:

:16R:GENL

:20C::CORP//BRUP09063007

:20C::SEME//BRUP09063007002

:23G:REPL

:22F::CAEV//BRUP

:22F::CAMV//MAND

:98C::PREP//20090630185516

:25D::PROC//PREC

:16R:LINK

:13A::LINK//564

:20C::PREV//BRUP09063007001

:16S:LINK

:16S:GENL

:16R:USECU

:35B:ISIN RU0009054449

uKOS, AOI

or YUKOS, COMMON

:16R:ACCTINFO

:97A::SAFE//123456

:94B::SAFE//SHHE/REGISTRAR

:93B::ELIG//UNIT/289730,

:16S:ACCTINFO

:16S:USECU

:16R:CADETL

:98A::ANOU//20060327

:98A::COAP//20060801

:98B::EFFD//20060812

:16S:CADETL

:16R:ADDINFO

:70E::ADTX//NASTOaqIM SOOBqAEM, cTO

MOSKOVSKIi ARBITRAJNYi SUD

INICIROVAL PROCEDURU BANKROTSTVA

V OTNOQENII eMITENTA

or

:70E::ADTX//PLEASE BE ADVISED THAT THE
ARBITRATION COURT OF MOSCOW HAS
INITIATED THE PROCEEDINGS REGARDING
THE BANKRUPTCY OF THE ISSUER

:70E::PACO//CONTACT PERSON NAME

PHONE NUMBER

PAX NUMBER

E MAIL ADDRESS

:16S:ADDINFO

3. After receiving information from the court on the bankruptcy decision the depository send notification to its clients on the corporate action with confirmed information replacing the previous notification (MT564/BRUP/RELP/COMP) and stating the date of the decision (98A::COAP/).

If the adjudication of the bankruptcy company declared bankrupt, a message to cancel a previous notification of corporate action considering that action won't be carried out (code WITH) should be sent. The court's decision announced on 29 July 2009.

This is an example of Corporate Action Notification sent by the depository (BIC DEPORUMM) to the account owner ABC BROKER (BIC BROKRUMM) and contains information on corporate action on safekeeping account 123456 on OAO "uKOS NK" securities.

The rules of financial instrument's indication are defined in section 1.8.5 of this document.

Notification is formed by the depository and contains information on details of corporate action – OAO "uKOS NK" bankruptcy termination.

Notification formation date and time – July 30th 2009, 18:58:11

MT564 – Corporate Action Notification

Corporate action reference BRUP09063007

Sender's reference – BRUP09063007003

Sender of MT564 DEPORUMM

Receiver of MT564 BROCKRUMM

Message structure:

:16R:GENL

:20C::CORP//BRUP09063007

:20C::SEME//BRUP09063007003

:23G:WITH

:22F::CAEV//BRUP

:22F::CAMV//MAND

:98C::PREP//20090730185811

:25D::PROC//COMP

:16R:LINK

:13A::LINK//564
 :20C::PREV//BRUP09063007002
 :16S:LINK
 :16S:GENL
 :16R:USECU
 :35B:ISIN RU0009054449
 'uKOS, AOI or YUKOS, COMMON
 :16R:ACCTINFO
 :97A::SAFE//123456
 :94B::SAFE//SHHE/REGISTRAR
 :93B::ELIG//UNIT/289730,
 :16S:ACCTINFO
 :16S:USECU
 :16R:CADETL
 :98A::ANOU//20060327
 :98A::COAP//20060801
 :98B::EFFD//OPEN
 :16S:CADETL
 :16S:CAOPTN
 :16R:ADDINFO
 :70E::ADTX/'NASTOaqIM SOOBqAEM, cTO
 MOSKOVSKIi ARBITRAJNYi SUD
 PRIZNAL eMITENTA KREDITOSPOSOBNYM
 or
 :70E::ADTX//PLEASE BE ADVISED THAT THE
 ARBITRATION COURT OF MOSCOW HAS
 ACKNOWLEDGED THE ISSUER TO BE
 CREDIT WORTHY
 :16S:ADDINFO

4. If a company is declared bankrupt, the depository sends to its clients notification on the corporate action informing the duration of bankruptcy proceedings with the date of receipt of further information (MT564/BRUP/REPL).

This is an example of Corporate Action Notification sent by the depository (BIC DEPORUMM) to the account owner ABC BROKER (BIC BROKRUMM) and contains information on corporate action on safekeeping account 123456 on OAO "uKOS NK" securities.

The rules of financial instrument's indication are defined in section 1.8.5 of this document.

Notification is formed by the depository and contains information on details of corporate action – declaring OAO "uKOS NK" bankrupt.

Notification formation date and time – July 30th 2009, 19:03:40

MT564 – Corporate Action Notification

Corporate action reference BRUP09063007

Sender's reference – BRUP09063007002

Sender of MT564 DEPORUMM

Receiver of MT564 BROCKRUMM

Message structure:

:16R:GENL
:20C::CORP//BRUP09063007
:20C::SEME//BRUP09063007003
:23G:REPL
:22F::CAEV//BRUP
:22F::CAMV//MAND
:98C::PREP//20090730190340
:25D::PROC//COMP
:16R:LINK
:13A::LINK//564
:20C::PREV//BRUP09063007002
:16S:LINK
:16S:GENL
:16R:USECU
:35B:ISIN RU0009054449
YUKOS, AOI or YUKOS, COMMON
:16R:ACCTINFO
:97A::SAFE//123456
:94B::SAFE//SHHE/REGISTRAR
:93B::ELIG//UNIT/289730,
:16S:ACCTINFO
:16S:USECU
:16R:CADETL
:98A::ANOU//20060327
:98B::EFFD//20060811
:98A::FDAT//20070801
:16S:CADETL
:16R:ADDINFO
:70E::ADTX/'NASTOaqIM SOOBqAEM, cTO
MOSKOVSKIi ARBITRAJNYi SUD
PRIZNAL eMITENTA BANKROTOM I
NAZNAcIL KONKURSNOE PROIZVODSTVO
SROKOM 1 GOD.
DOPOLNITELXNAa INFORMACIa BUDET
DOSTUPNA PO REZULXTATAM
KONKURSNOGO PROIZVODSTVA
or
:70E::ADTX//PLEASE BE ADVISED THAT THE
ARBITRATION COURT OF MOSCOW HAS
ACKNOWLEDGED THE ISSUER TO BE
BANKRUPT AND INITIATED THE WINDING
UP PROCEEDINGS WITH 1 YEAR
DURATION.
FURTHER INFORMATION WILL
BE ANNOUNCED AFTER THE CONCLUSION
OF WINDING UP PROCEEDINGS

:16S:ADDINFO

Example 2b. Corporate Action Type – distribution of cash as a result of liquidation (corporate action event indicator – LIQU)

5. Subsequent to liquidation process in case of cash outflow the depository makes additional corporate action (LIQU) and sends notification on the corporate action stating reference of the previous corporate action (BRUP), and based on the liquidation outflows the depository sends to its clients corporate action confirmation informing about the cash flows (MT566/LIQU).

MT564 – Corporate Action Notification

Corporate action reference LIQU07063007
Sender's reference – LIQU07063007002

Sender of MT564 DEPORUMM
Receiver of MT564 BROCKRUMM

Message structure:

:16R:GENL
:20C::CORP//LIQU07063007
:20C::SEME//LIQU07063007003
:23G:REPL
:22F::CAEV//LIQU
:22F::CAMV//MAND
:98C::PREP//20070828190340
:25D::PROC//COMP
:16R:LINK
:13A::LINK//564
:20C::PREV//BRUP09063007002
:16S:LINK
:16R:LINK
:20C::PREV//BRUP09063007002
:16S:LINK
:16S:GENL
:16R:USECU
:35B:ISIN RU0009054449
YUKOS, AOI or YUKOS, COMMON
:16R:ACCTINFO
:97A::SAFE//123456
:94B::SAFE//SHHE/REGISTRAR
:93B::ELIG//UNIT/289730,
:16S:ACCTINFO
:16S:USECU
:16R:CADETL
:98A::ANOU//20060327
:98B::EFFD//200770827

:16S:CADETL
:16R:CAOPTN
:13A::CAON//001
:22F::CAOP//CASH
:17B::DFLT//Y
“16S:CAOPTN
:16R:ADDINFO
:70E::ADTX//NASTOaqIM SOOBqAEM, O
VYPLATE PO REZULXTATAM
KONKURSNOGO PROIZVODSTVA
or
:70E::ADTX//PLEASE BE ADVISED THAT THE
WINDING UP PROCEEDINGS WITH 1 YEAR
DURATION IS TERMINATED AND LIQUIDATION
PATMENT WILL BE DONE.
:16S:ADDINFO

Upon receipt of the liquidation results and compensatory amount, message on completion of bankruptcy procedure is sent to the shareholders.

MT566 – Corporate action confirmation

Corporate action reference LIQU07063007
Sender’s reference – LIQU07063007004

Sender of MT566 DEPORUMM
Receiver of MT566 BROCKRUMM

Message structure:

:16R:GENL
:20C::CORP//LIQU07063007
:20C::SEME//LIQU07063007004
:23G:NEWM
:22F::CAEV//LIQU
:98C::PREP//20090630191837
:16R:LINK
:13A::LINK//564
:20C::PREV//LIQU07063007003
:16S:LINK
:16R:LINK
:20C::CORP//BRUP09063007
:16S:LINK
:16S:GENL
:16R:USECU
:97A::SAFE//123456
:94B::SAFE//SHHE/REGISTRAR
:35B:ISIN RU0009054449
‘uKOS, AOI or YUKOS, COMMON
:93B::CONB//UNIT/289730,
:16S:USECU

:16R:CADETL
 :98B::EFFD//200770901
 :90B::OFFR//ACTU.RUB0,
 :16S:CADETL
 :16R:CACONF
 :13A::CAON//001
 :22F::CAOP//CASH
 :90B::OFFR//ACTU/RUB0,
 :16R:CASHMOVE
 :22H::CRDB//CRED\;16R:CSHPRTY
 :95P::BENM//XXXXXXXXXX
 :97A::CASH//456789
 :16S:CSHPRTY
 :19B::GRSS//RUB5000,
 :19B::NETT//RUB500,
 :19B::PSTA//RUB4500,
 :98A::POST//20070920
 :16S:CASHMOVE
 :16S:CACONF

Example 2c. Corporate Action Type – booking out of valueless securities upon receipt of confirmation from the registrar (corporate action code – WRTH)

6. Upon receipt of all the documents necessary for withdrawal of the securities from depository the depository initiates additional corporate action (WRTH) related to main corporate action (BRUP) sends to its client notification on the forthcoming withdrawal of securities, and after receiving confirmation from the registrar – Confirmation on the corporate action MT566 – of the securities withdrawal.

Upon receipt of the information on the forthcoming securities withdrawal the depository sends to its clients information on the corporate action – withdrawal of the securities.

MT564 – Corporate Action Notification

Corporate action reference WRTH07063007
 Sender's reference – WRTH07063007002

Sender of MT564 DEPORUMM
 Receiver of MT564 BROCKRUMM

Message structure:

:16R:GENL
 :20C::CORP//WRTH07063007
 :20C::SEME//WRTH07063007003
 :23G:REPL
 :22F::CAEV//LIQU
 :22F::CAMV//MAND

:98C::PREP//20070828190340
 :25D::PROC//COMP
 :16R:LINK
 :13A::LINK//564
 :20C::PREV//BRUP09063007002
 :16S:LINK
 :16R:LINK
 :20C::PREV//BRUP09063007002
 :16S:LINK
 :16S:GENL
 :16R:USECU
 :35B:ISIN RU0009054449
 'uKOS, AOI or YUKOS, COMMON
 :16R:ACCTINFO
 :97A::SAFE//123456
 :94B::SAFE//SHHE/REGISTRAR
 :93B::ELIG//UNIT/289730,
 :16S:ACCTINFO
 :16S:USECU
 :16R:CADETL
 :98A::ANOU//20071018
 :98B::EFFD//20071030
 :16S:CADETL
 :16R:CAOPTN
 :13A::CAON//001
 :22F::CAOP//CASH
 :17B::DFLT//Y
 "16S:CAOPTN
 :16R:ADDINFO
 :70E::ADTX//PLEASE BE ADVISED THAT AFTER
 FINALIZATION OF THE WINDING UP
 PROCEEDINGD THE COMPANY SHARES
 BECAME WORTHLESS AND WILL BE BOOKED OUT.
 BEST REGARDS,
 CUSTODY OF ZAO BANK ABCD
 :16S:ADDINFO

MT566 – Corporate action confirmation

Corporate action reference WRTH09063007
 Sender's reference – WRTH09063007005

Sender of MT566 DEPORUMM
 Receiver of MT566 BROCKRUMM

Message structure:

:16R:GENL
 :20C::CORP// WRTH09063007
 :20C::SEME// WRTH09063007005
 :23G:NEWM

:22F::CAEV//WRTH
 :98C::PREP//20071101090917
 :16R:LINK
 :16R:LINK
 :20C::CORP//BRUP09063007
 :16S:LINK
 :16R:LINK
 :20C::CORP//BRUP09063007
 :16S:LINK
 :16S:GENL
 :16R:USECU
 :97A::SAFE//123456
 :94B::SAFE//SHHE/REGISTRAR
 :35B:ISIN RU0009054449
 'uKOS, AOI or YUKOS, COMMON
 :93B::CONB//UNIT/289730,
 :16S:USECU
 :16R:CADETL
 :98B::EFFD//20071030
 :90B::OFFR//ACTU/RUB0,
 :16S:CADETL
 :16R:CACONF
 :13A::CAON//001
 :22F::CAOP//CASH
 :16R:SECMOVE
 :22H::CRDB//CRED
 :35B:ISIN RU0009054449
 'uKOS, AOI or YUKOS, COMMON
 :36B::PSTA//UNIT/291730,
 :98A::POST//20071031
 :98A::VALU//20071030
 :16S:SECMOVE
 :16S:CACONF
 :16R:ADDINFO
 :70E::TXNR//PLEASE BE ADVISED THAT WORTHLES
 SHARES HAVE BEEN BOOKED OUT FROM
 YOUR ACCOUNT IN ACCORDANCE WITH
 LIQUIDATION PROCEDURE OF THE
 COMPANY.
 BEST REGARDS,
 CUSTODY ZAO ABCD BANK
 :16S:ADDINFO

5.1.3. Example 3. Corporate Action Type – Merger (corporate action indicator – MRGR)

MAIN TERMS OF CORPORATE ACTION

Definition

Mandatory or non-mandatory exchange of outstanding shares due to merger of assets of two or more companies. Exchange may be accompanied by payments.

Initial terms:

-Issuer – OAO “MOSeNERGO HOLDING”

Details of issue:

common stock:

ISIN RU000A0JPVQ5

Identification number (assigned by FCSM) – 2RVP-01-55388-E

State registration date August 14th 2001

preferred capital stock:

ISIN RU000A0JPVR3

Identification number (assigned by FCSM) – 2RVP-01-55388-E

State registration date August 14th 2001

Merging of OAO “MOSeNERGO HOLDING” with OAO “MOSeNERGO”

Transferring company: OAO “MOSeNERGO HOLDING”

Securities of OAO “MOSeNERGO”:

common stock:

ISIN RU0008958863

National state registration number – 1-01-00085-A

State registration date June 17th 2003

Record date (owners of shares listing date): June 6th 2008

Date of the transactions in the registrar: July 1st 2008

Corporate action is mandatory and instruction from the owner of securities to participate in the corporate action is not required (CAMV/MAND).

Additional terms:

Conversion ratio (preferred capital stock of OAO “MOSeNERGO HOLDING” into common stock of OAO “MOSeNERGO”):

1 common stock of OAO “MOSeNERGO” for 3.2499805529529 shares of OAO “MOSeNERGO HOLDING”

Mathematical rounding rules should be used when calculating the number of new shares of OAO “MOSeNERGO” to the owner.

Deposited shares of OAO “MOSeNERGO” will be traded from July 2nd 2008.

Additional terms:

Safekeeping account number: 123456

Quantity of securities on the date of the listing of registered persons: (June 6th 2008) – 63 (preferred capital stock).

Corporate Action Notification on common stock is not sent as the common stock is not on safekeeping account.

This is an example of Corporate Action Notification sent by the depository (BIC DEPORUMM) to the account owner ABC BROKER (BIC BROKRUMM) and contains information on corporate action on safekeeping account 123456 on OAO “MOSeNERGO HOLDING” securities ISIN RU000A0JPVR3

The rules of financial instrument’s indication are defined in section 1.8.13 of this document.

1. Upon receipt of the information the depository sends to its client notification on the corporate action which contains full information regarding the details of the corporate action (MT564/NEWM/MRGR/COMP):

– Merging of OAO “MOSeNERGO HOLDING” with OAO “MOSeNERGO”.

Sender’s reference – AE79HC/080723/50

Corporate action reference – RAOREORG123

Notification formation date/time – June 24th 2008, 17:00

Full information is provided on the corporate action (PROC/COMP)

At the time of sending notification (MT564) the date of the transactions in the registry is unknown.

Can be used only one option - the exchange of certain securities upon the other, this option is set as default without receiving instructions from the owners.

The previous securities (ISIN RU000A0JPVR3) will be written off (debited) from the account (CRDB / DEBT).

MT564 – Corporate Action Notification

Corporate action reference – RAOREORG123

Sender’s reference – AE79HC/080723/50

Sender of MT564 DEPORUMM

Receiver of MT564 BROCKRUMM

Message structure:

:16R:GENL

:20C::CORP//RAOREORG123

:20C::SEME//AE79HC/080723/50

:23G:NEWM

:22F::CAEV//MRGR

:22F::CAMV//MAND

:98A::PREP//20080624

:25D::PROC//COMP

:16S:GENL

:16R:USECU

:35B:ISIN RU000A0JPVR3

'MOSeNERGO HOLDING, API or MOSENERGO HOLDING PREF

:16R:ACCTINFO

:97A::SAFE//123456

:93B::SETT//UNIT/63,

:93B::ELIG//UNIT/63, or once :93C::SETT//UNIT/ELIG/63,

:16S:ACCTINFO

:16S:USECU

:16R:CADETL

:98A::RDTE//20080606

:16S:CADETL

:16R:CAOPTN

:13A::CAON//001

:22F::CAOP//SECU

:17B::DFLT//Y
 :16R:SECMOVE
 :22H::CRDB//DEBT
 :35B:ISIN RU000A0JPVR3
 'MOSeNERGO HOLDING, API or MOSENERGO HOLDING PREF
 :98B::PAYD//UKWN
 or if the date of the transaction in the registry is known at the time the MT564
 :98A::PAYD//20080701
 :16S:SECMOVE
 :16R:SECMOVE
 :22H::CRDB//CRED
 :35B:ISIN RU0008958863
 'MOSeNERGO, AOI or MOSENERGO ORD.
 :98B::PAYD//UKWN
 or if the date of the transaction in the registry is known at the time the MT564
 :98A::PAYD//20080701
 :16S:SECMOVE
 :16S:CAOPTN
 :16R:ADDINFO
 :70E::ADTX//NASTOaqIM SOOBqAEM, cTO V
 ZAKLucITELXNOi STADII
 REORGANIZACII RAO EeS ROSSII
 MOSeNERGO HOLDING SOLXETSa S MOSeNERGO.
 or
 :70E::ADTX//PLEASE BE ADVISED THAT BEING A
 FINAL STAGE OF RAO UES
 REORGANIZATION MOSENERGO HOLDING
 AND MOSENERGO WILL MERGE
 VIA EXCHANGE OF MOSENERGO
 HOLDING SHS FOR MOSENERGO SHS
 :70E::PACO//CUSTODY DEPT
 PETROV IVAN
 TEL 8 499 245 75 68
 EMAIL PETROV (AT) DEPO.RU
 :16S:ADDINFO

2. Upon receipt of report on the results of corporate action from the registrar the depository sends to its client Confirmation on the corporate action informing the book out of old shares and deposition of new shares (MT566/NEWM/MRGR).

Upon receipt of report on the results of corporate action from the registrar the depository (BIC DEPORUMM) posts account operation and sends to the account owner ABC Broker (BIC BROKRUMM) confirmation on the corporate action which contains confirmation on the corporate action at depo account 123456 for Mosenergo Holding ISIN RU000A0JPVR3.

Sender's reference – AE79HC/080723/51

Corporate action reference – RAOREORG123

Shares under corporate action – OAO MOSeNERGO HOLDING ISIN RU000A0JPVR3

Corporate action type – MRGR

Date in depository – 07 July 2008

Date in registrar – 01 July 2008

Confirmation contains additional terms of corporate action:

Swap ratio (preferred shares of OAO MOSeNERGO HOLDING into common stock of OAO MOSeNERGO:

1 share of OAO MOSeNERGO accrue 3.2499805529529 shares of AOA MOSeNERGO HOLDING.

In calculating the amount due to the owner of new shares of "MOSeNERGO" standard rounding rule is used, i.e. the mathematical rounding rules.

MT566 – Corporate Action Confirmation

Corporate action reference – RAOREORG123

Sender's reference – AE79HC/080723/51

Sender of MT566 DEPORUMM

Receiver of MT566 BROCKRUMM

Message structure:

:16R:GENL
:20C::CORP//RAOREORG123
:20C::SEME//AE79HC/MSNG/51
:23G:NEWM
:22F::CAEV//MRGR
:16R:LINK
:13A::LINK//564
:20C::PREV//AE79HC/080723/50
:16S:LINK
:16S:GENL
:16R:USECU
:97A::SAFE//1234567
:35B:ISIN RU000A0JPVR3
'MOSeNERGO HOLDING, API or MOSENERGO HOLDING PREF
:93B::CONB//UNIT/63,
:16S:USECU
:16R:CADETL
:98A::RDTE//20080606
:98A::EFFD//20080707
:16S:CADETL
:16R:CACONF
:13A::CAON//001
:22F::CAOP//SECU
:22F::DISF//STAN
:16R:SECMOVE
:22H::CRDB//DEBT
:35B:ISIN RU000A0JPVR3
'MOSeNERGO HOLDING, API or MOSENERGO HOLDING PREF
:36B::PSTA//UNIT/63,
:98A::POST//20080707
:98A::PAYD//20080701
:16S:SECMOVE
:16R:SECMOVE

:22H::CRDB/CRED
 :35B::ISIN RU0008958863
 MOSeNERGO, AOI or MOSENERGO ORD.
 :36B::PSTA//UNIT/19,
 :92D::NEWO//1,/3,2499805529529
 :98A::POST//20080707
 :98A::PAYD//20080701
 :98A::AVAL//20080702
 :16S::SECMOVE
 :16S::CACONF
 :16R::ADDINFO
 70E::TXNR//AS A RESULT OF THE MERGER OF
 MOSENERGO HOLDING (RU000A0JPVR3)
 and MOSENERGO (RU0008958863) YOUR
 MOSENERGO HOLDING PEF SHS
 WERE MANDATORY EXCHANGED FOR
 MOSENERGO ORD SHS ON JULY 07,2008
 WITH VALUE DATE JULY 01,2007 AT THE
 RATIO 3,2499805529529900 OLD TO 1
 NEW SHS. NEWLY ISSUED SHS ARE
 TRADABLE.
 :70E::PACO//SHOULD YOU HAVE ANY QUESTIONS,
 PLEASE CONTACT:
 PERSON NAME
 TEL 7 789 012 34 56
 FAX 7 789 012 34 56
 EMAIL XXXXX (AT) XXX.XX
 :16S::ADDINFO

5.1.4. Example 4. Corporate Action Type – PARI-PASSU of additional issues (corporate action event indicator – PARI)

MAIN TERMS OF CORPORATE ACTION

Definition:

Occurs when securities with different characteristics, e.g. shares with different rights to dividends, become identical in all respects. May be declared in advance (e.g. bonus shares can be equated to the previously issued in a predetermined time) or be the result of external actions - the merger, reorganization, issuance of additional trenches, etc. In accordance with this recommendation the code is also used when consolidating of securities issue.

Consolidation of shares issue of OAO “VOLJSKAa TGK”

Initial terms:

-Issuer – OAO “VOLJSKAa TGK” or OAO “TGK-7”
 Registrar: OAO “CENTRALXNYi MOSKOVSKi DEPOZITARI”

Details of principal issue:

1. Common stock

RU000A0HML36 – code of additional issue matches the principal issue ISIN code
National state registration number – 1-01-55113-E-010D
State registration date – May 20th 2008
Nominal value – 1 ruble
Coefficient – 1,0

2. Common stock

RU000A0HML36 – code of additional issue matches the principal issue ISIN code
National state registration number – 1-01-55113-E-010D
State registration date – May 20th 2008
Nominal value – 1 ruble
Coefficient – 1,0

3. Principal issue – common stock

RU000A0HML36
National state registration number – 1-01-55113-E
State registration date – November 1st 2005
Nominal value – 1 ruble
Record date of holding for operation in depository – 11.01.2009

Additional terms:

Safekeeping account number: 123456
Quantity of securities to the date of the MT564 on expected corporate action in depository (07.01.2009).
1-01-55113-E-009D – 150.000
1-01-55113-E-010D – 370.000

Quantity of securities to the record date of holding in depository (11.01.2009):

1-01-55113-E-009D – 250.000
1-01-55113-E-010D – 300.000

Basis – received information from OAO “CENTRALXNYI MOSKOVSKI DEPOZITARI” Registrar.

Providing instruction from the clients is not required (corporate action is mandatory).

1. Receiving/publishing by the issuer information on consolidation of securities issue and cancellation of additional issues – published on December 15th 2008, the depository sends to its client notification on the corporate action (MT564/NEWM/PREU)

It is possible to send MT564/PARI (function NEWM).

In field :25D: it should be indicated – preliminary information about consolidates securities issue and cancellation of additional issues – unconfirmed information (PROC//PREU).

MT564 should be send upon every additional securities issue.

In case of consolidation of several additional issues into one main issue with cancellation of additional issues happens at the same date, such corporate action is given a common reference for corporate action for all consolidated issues.

For each additional issue individual notification on corporate action (MT564) should be

sent and details of the additional issue are specified in USECU subsequence. Accordingly, it is given a unique reference (: 20C :: SEME / /). .

MT564 – Corporate Action Notification

Corporate action reference – VTGK301208

Sender's reference – 081215123456

Sender of MT564 DEPORUMM

Receiver of MT564 BROCKRUMM

Message structure:

:16R:GENL
:20C::CORP//VTGK301208
:20C::SEME//081215123456
:23G:NEWM
:22F::CAEV//PARI
:22F::CAMV//MAND
:98C::PREP//20081216180000
:25D::PROC//PREU
:16S:GENL
:16R:USECU
:35B:ISIN RU000A0HML36
/RU/1-01-551113-E-009D
'VOLJSKAa TGK'
:16R:ACCTINFO
:97A::SAFE//123456
:93B::ELIG//UNIT/150000,
:16S:ACCTINFO
:16S:USECU
:16R:INTSEC
:35B:ISIN RU000A0HML36
/RU/1-01-551113-E
'VOLJSKAa TGK'
:98A::POST//20081230
:98A::EXPI//20081230
:16S:INTSEC
:16R:CADETL
:98A::RDTE//20090112
(RU000A0HML36)
:16S:CADETL
:16R:CAOPTN
:13A::CAON//001
:22F::CAOP//SECU
:17B::DFLT//Y
:16R:SECMOVE
:22F::CRDB//DEBT:
:35B:ISIN RU000A0HML36
/RU/1-01-551113-E-010D
'VOLJSKAa TGK'

:36B::ENTL//UNIT/150000,
:16S:SECMOVE
:16R:SECMOVE
:22F::CRDB//CRED
:35B:ISIN RU000A0HML36
/RU/1-01-551113-E
'VOLJSKAa TGK'
:36B::ENTL//UNIT/150000,
:92D::NEWO//1,/1,
:16S:SECMOVE
:16S:CAOPTN
:16R:ADDINFO
:70E::TXNR//CANCELLATION OF ADDITIONAL ISSUE
AND CONVERSION INTO ONE MAIN ISSUE
:16S:ADDINFO

2. Receiving information from the issuer on the consolidated securities issue – January 10th 2009 and informing depositors on the expected consolidation of the issues.

It is possible to send MT564/PARI (function REPL).

In field :25D: it should be indicated – full information on consolidation is provided.
MT564/PARI/COMP

Additional it is possible to send to the owner of the account MT568 describing the details of corporate action with the link to MT564.

2.1 MT564 – Corporate Action Notification

Corporate action reference – VTGK301208

Sender's reference – 081215123458

Sender of MT564 DEPORUMM

Receiver of MT564 BROCKRUMM

Message structure:

:16R:GENL
:20C::CORP//VTGK301208
:20C::SEME//080107123458
:23G:REPL
:22F::CAEV//PARI
:22F::CAMV//MAND
:98C::PREP//20090110174505
:25D::PROC//COMP
:16R:LINK
:13A::LINK//564
:20C::PREV//081215123456
:16S:LINK
:16S:GENL

:16R:USECU
:35B:ISIN RU000A0HML36
/RU/1-01-551113-E-009D
'VOLJSKAa TGK'
:16R:ACCTINFO
:97A::SAFE//123456
:93B::ELIG//UNIT/250000,
:16S:ACCTINFO
:16S:USECU
:16R:INTSEC
:35B:ISIN RU000A0HML36
'VOLJSKAa TGK'
:36B::QINT//UNIT/250000,
:98A::EXPI//20090111
:98A::POST//20090112
:16S:INTSEC
:16R:CADETL
:98A::RDTE//20090111
:22F::CONV//FINL
:16S:CADETL
:16R:CAOPTN
:13A::CAON//001
:22F::CAOP//SECU
:17B::DFLT//Y
:16R:SECMOVE
:22F::CRDB//DEBT:
:35B:ISIN RU000A0HML36
/RU/1-01-551113-E-009D
'VOLJSKAa TGK'
:36B::ENTL//UNIT/250000,
:16S:SECMOVE
:16R:SECMOVE
:22F::CRDB//CRED
:35B:ISIN RU000A0HML36
/RU/1-01-551113-E
'VOLJSKAa TGK'
:36B::ENTL//UNIT/250000,
:92D::NEWO//1,1,
:16S:SECMOVE
:16S:CAOPTN
:16R:ADDINFO
:70E::TXNR//CANCELLATION OF ADDITIONAL ISSUE
AND CONVERSION INTO ONE ISSUE (RU000A0HML36)
:16S:ADDINFO

3. Upon receipt of information from the registrar on the issue consolidation (statement of transactions) the client receives Confirmation on the corporate action (MT566)

Date of operation in registrar – 11 January 2009

Date of operation in depository – 12 January 2009

-MT566/PARI/NEWM

In case of consolidation of several additional issues into one main issue with cancellation of additional issues happens at the same date, for each additional issue individual Confirmation on corporate action (MT566) should be sent. And each message is given unique reference (: 20C :: SEME / /). .

3.1 MT566 – Corporate Action Confirmation

Corporate action reference – VTGK301208
Sender's reference – 081215123462

Sender of MT566 DEPORUMM
Receiver of MT566 BROCKRUMM

Message structure:

:16R:GENL
:20C::CORP//VTGK301208
:20C::SEME//081215123462
:23G:NEWM
:22F::CAEV//PARI
:98C::PREP//20090112
:16R:LINK
:13A::LINK//564
:20C::PREV//0801123458
:16S:LINK
:16S:GENL
:16R:USECU
:97A::SAFE//123456
:35B:ISIN RU000A0HML36
/RU/1-01-551113-E-009D
'VOLJSKAa TGK'
:93::CONB//UNIT/250000,
:16S:USECU
:16R:CADETL
:98A::EFFD//20090111
:16S:CADETL
:16R:CACONF
:13A::CAON//001
:22F::CAOP//SECU
:16R:SECMOVE
:22H::CRDB//DEBT
:35B:ISIN RU000A0HML36
/RU/1-01-551113-E-009D
:36B::PSTA//UNIT/250000,
:98A::POST//20090112
:98A::PAYD//20090111
:16S:SECMOVE
:16R:SECMOVE
:22H::CRDB//CRED

:35B:ISIN RU000A0HML36
/RU/1-01-551113-E
'VOLJSKAa TGK'
:36B::PSTA//UNIT/250000,
:92D::NEWO//1,/1,
:98A::POST//20090111
:98A::AVAL/20090111
:16S:SECMOVE
:16S:CACONF
:16R:ADDINFO
:70E::TXNR//CANCELLATION OF INDIVIDUAL NUMBER OF
ADDITIONAL ISSUE AND CONVERSION
INTO ONE ISSUE FOR WHICH THE ISSUE WAS
SUPPLEMENTARY (RU000A0HML36)
:16S:ADDINFO

**5.1.5. Example 5. Corporate Action Type – Priority issue
(public offer where, priority is given to existing shareholders.
(corporate action event indicator – PRIO)**

Definition:

Public offering where existing shareholders have privilege of share purchase as the number of shares is limited.

Initial terms:

-Issuer – OAO “RUSGIDRO” (former OAO “FEDERALNAa GIDROGENERIRUuqAa KOMPANIa”)

-Date of the Extraordinary Meeting of Shareholders where it was decided to increase the share capital by issuing additional shares - 17.11.2008

-Date of listing persons with prior option of purchase – 08.10.2008

Details of prior issue:

National state registration number – 1-01-55038-E-037D

State registration date – May 14th 2009

Nominal value – 1 ruble

Offer price – 1 ruble

Period of prior option of purchase – 45 days – from 15.05.2009 to 29.06.2009

Currency of payment – Russian ruble

Due date – not later than 29.06.2009

Period of depositing securities – 06.07.2009

Start date of circulation (after registration of the report on the results of issue in FCSM) – August 1st 2009

Coefficient – 0.0627416488067

Additional terms:

Safekeeping account number: 123456

Quantity of securities to the date of listing: 759,696

Deadline of instruction to the depository – 15.06.2009

Owner obtains 40000 of new shares.

Issuing additional shares among existing shareholders with prior option of purchase. Date of listing shareholders is the date of listing of shareholders (08.10.2008) which participated in the meeting at which it was decided to increase the share capital by issuing additional shares (17/11/2008).

Receiving information about an upcoming meeting of shareholders concerning the increase of authorized capital by issuing additional shares.

No action (it is possible to send MT564/MEET/XMEET indicating in field 70E://potential voluntary corporate action).

Receiving information on the outcome of the shareholder's meeting where the decision was made. It is possible to send to the account owner a corporate action notification as a preliminary unconfirmed information MT 564/PRIO/NEWM/PREU

MT564 – Corporate Action Notification

Corporate action reference – CA HYDR140509

Sender's reference – LAGUYU0905181453

Sender of MT564 DEPORUMM

Receiver of MT564 BROCKRUMM

Message structure:

:16R:GENL

:20C::CORP//CA HYDR140509

:20C::SEME//LAGUYU0905181453

:23G:NEWM

:22F::CAEV//PRIO

:22F::CAMV//VOLU

:25D::PROC//PREU

:16S:GENL

:16R:USECU

:35B:ISIN RU000A0JPKH7

RUSGIDRO, AOI

or JSC RUSHYDRO

:16R:ACCTINFO

:97A::SAFE//123456

:93B::ELIG//UNIT/759696,

:16S:ACCTINFO

:16S:USECU

:16R:CADETL

:98C::MEET//20081117000000

:98A::RDTE//20081008

:16S:CADETL

:16R:CAOPTN

:13A::CAON//001

:22F::CAOP//SECU

:17B::DFLT//N

:90B::OFFR//ACTU/RUB1,

:16S:CAOPTN
:16R:CAOPTN
:13A::CAON//002
:22F::CAOP//NOAC
:17B::DFLT//Y
:16S:CAOPTN

1. When an Issuer receives Priority issue notification or after Issuer publishes this information, corporate action notification should be sent to the account owner (MT564/PRIO/COMP). Additionally MT564 should be sent to the account owner with details of the corporate action with the link to MT564.

MT564 – Corporate Action Notification

Corporate action reference – CA HYDR140509
Sender's reference – LAGUYU0905181454

Sender of MT564 DEPORUMM
Receiver of MT564 BROCKRUMM

Message structure:

:16R:GENL
:20C::CORP//CA HYDR140509
:20C::SEME//LAGUYU0905181454
:23G:REPL
:22F::CAEV//PRIO
:22F::CAMV//VOLU
:25D::PROC//COMP
:16R:LINK
:13A::LINK//564
:20C::PREV//LAGUYU0905181453
:16S:LINK
:16S:GENL
:16R:USECU
:35B:ISIN RU000A0JPKH7
RUSGIDRO, AOI or JSC RUSHYDRO
:16R:ACCTINFO
:97A::SAFE//123456
:93B::ELIG//UNIT/759696,
:16S:ACCTINFO
:16S:USECU
:16R:CADETL
:98C::MEET//20081117000000
:98A::RDTE//20081008
:16S:CADETL
:16R:CAOPTN
:13A::CAON//001
:22F::CAOP//SECU
:17B::DFLT//N
:98C::MKDT//20090629170000
:98C::RDDT//20090615150000

:69A::PWAL//20090515/20090629
:90B::PRPP//ACTU/RUB1,
:16R:SECMOVE
:22H::CRDB//CRED
:35B:ISIN RU000A0JPKH7
'RUSGIDRO, AOI or JSC RUSHYDRO
:36B::ENTL//UNIT/43919,
:92D::ADEX//0,0627416488067/1,
:98B::PAYD//UKWN
:16S:SECMOVE
:16S:CAOPTN
:16R:CAOPTN
:13A::CAON//002
:22F::CAOP//NOAC
:17B::DFLT//Y
:16S:CAOPTN
:16R:ADDINFO
:70E::TXNR//PRE-EMPTIVE RIGHTS TO BUY THE NEW
REGISTERED ORDINARY SHARES OF JSC RU
SHYDRO (ISIN RU000A0JPKH7).
:70E::ADTX//"DOPOLNITELXNAa INFORMACIa V SOOBqENII
MT568 S KODOM HYDR140509
или
:70E::ADTX//SWIFT WILL BE CONTINUED ON MT568
WITH CORP CA HYDR140509
:16S:ADDINFO

MT568 – Corporate Action Narrative

Corporate action reference – CA HYDR140509
Sender's reference – LAGUYU0905181455

Sender of MT568 DEPORUMM
Receiver of MT568 BROCKRUMM

Message structure:

:16R:GENL
:20C::CORP//CA HYDR140509
:20C::SEME//LAGUYU0905181455
:23G:NEWM
:22F::CAEV//PRIO
:16R:LINK
:13A::LINK//564
:20C::PREV//LAGUYU0905181454
:16S:LINK
:16S:GENL
:16R:USECU
:97A::SAFE//123456
:35B:ISIN RU000A0JPKH7
'RUSGIDRO, AOI or JSC RUSHYDRO

:93B::ELIG//UNIT/700000,
:16S:USECU
:16R:ADDINFO
:70F::ADTX//NASTOaqIM SOOBqAEM, cTO 17 NOaBRa 2008 GODA OBqEE
SOBRANIE AKCIONEROV UTVERDILO UVELIcENIE USTAVNOGO
KAPITALA PUTEM VYPUSKA 16000000000 DOPOLNITELXNYH
OBYKNOVENNYH AKCIi NOMINALOM 1 RUBLX POSREDSTVOM OTKRYTOi
PODPISKI. 14 MAa 2009 GODA FSFR ZAREGISTRIROVALA NOVYi
VYPUSK I PRISVOILA EMU NOMER '1-01-55038-E-037D'. V
SOOTVETSTVII SO STATXaMI 40,41 ZAKONA "OB AKCIONERNYH
OBqESTVAH", AKCIONERY IMEuqIE PO SOSTOaNiU NA 8 OKTaBRa
2008 GODA AKCII eMITENTA IMEuT PRAVO NA PREIMUqESTVENNOE
PRIOBRETENIE CENNYH BUMAG PROPORCIONALXNO SVOIM AKCIaM.
POSLEDNIi SROK OPLATY AKCIi 15 IuNa 2009 GODA. PRI
PODAcE DOKUMENTOV NA OSUqESTVLENIE PREIMUqESTVENNOGO
PRAVA NEOBHODIMO PRILOJITX DOKUMENT OB OPLATE CENNYH
BUMAG

or

:70F::ADTX//PLEASE BE ADVISED THAT ON NOVEMBER 17, 2008 THE
GENERAL
SHAREHOLDER MEETING APPROVED THE CHARTER CAPITAL INCREASE BY
MEANS OF
ISSUANCE OF 16,000,000,000 ADDITIONAL ORDINARY SHARES WITH RUB1.00
PAR
VALUE EACH TO BE PLACED THROUGH OPEN SUBSCRIPTION. ON MAY 14,
2009,
FEDERAL FINANCIAL MARKETS SERVICE REGISTERED NEW ISSUE OF
16,000,000,000 RUSHYDRO ORDINARY SHARES UNDER THE STATE
REGISTRATION NUMBER 1-01-55038-E-037D. IN ACCORDANCE WITH
ARTICLES 40, 41 OF THE FEDERAL LAW ON JOINT STOCK COMPANIES, THE
HOLDERS OF RUSHYDRO ORDINARY SHARES AS OF OCTOBER 08, 2008 HAVE
PRE-EMPTIVE RIGHTS TO BUY THE NEW ORDINARY SHARES ON A PRO-RATA
BASIS. PAYMENT IN RUBLES FOR THE NEW SHARES SHALL BE MADE
BY JUNE 15, 2009 AT THE LATEST. APPLICATION FOR PRE-EMPTIVE RIGHT
PARTICIPATION SHOULD ENCLOSE ORIGINAL PAYMENT DOCUMENTS
CONFIRMING
MONEY TRANSFER. FOR ADDITIONAL INFORMATION PLEASE CONTACT OUR
GROUP EMAIL BEST REGARDS, CORPORATE ACTIONS
:16S:ADDINFO

2. Before the deadline for the instructions on corporate action the depository sends to its clients notification on corporate action – reminder to send the instructions MT 564/PRIO/RMRD.

MT564 – Corporate Action Notification

Corporate action reference – CA HYDR140509
Sender's reference – LAGUYU0906080931

Sender of MT564 DEPORUMM
Receiver of MT564 BROCKRUMM

Message structure:

:16R:GENL
:20C::CORP//CA HYDR140509
:20C::SEME//LAGUYU0906080931
:23G:RMDR
:22F::CAEV//PRIO
:22F::CAMV//VOLU
:25D::PROC//COMP
:16R:LINK
:20C::PREV//LAGUYU0905181454
:16S:LINK
:16S:GENL
:16R:USECU
:35B:ISIN RU000A0JPKH7
RUSGIDRO, AOI or JSC RUSHYDRO
:16R:ACCTINFO
:97A::SAFE//123456
:93B::ELIG//UNIT/759696,
:16S:ACCTINFO
:16S:USECU
:16R:CADETL
:98C::MEET//20081117000000
:98A::RDTE//20081008
:16S:CADETL
:16R:CAOPTN
:13A::CAON//001
:22F::CAOP//SECU
:17B::DFLT//N
:98C::MKDT//20090629170000
:98C::RDDT//20090615150000
:69A::PWAL//20090515/20090629
:90B::PRPP//ACTU/RUB1,
:16R:SECMOVE
:22H::CRDB//CRED
:35B:ISIN RU000A0JPKH7
RUSGIDRO, AOI or JSC RUSHYDRO
:36B::ENTL//UNIT/43919,
:92D::ADEX//0,0627416488067/1,
:98B::PAYD//UKWN
:16S:SECMOVE
:16S:CAOPTN
:16R:CAOPTN
:13A::CAON//002
:22F::CAOP//NOAC
:17B::DFLT//Y
:16S:CAOPTN
:16R:ADDINFO
:70E::TXNR//PRE-EMPTIVE RIGHTS TO BUY THE NEW
REGISTERED ORDINARY SHARES OF JSC RU

SHYDRO (ISIN RU000A0JPKH7).
:16S:ADDINFO

3. Client sends to the depository instructions for corporate action.

MT565 – Corporate Action Instruction

Corporate action reference – CA HYDR140509
Sender's reference – LAGUYU0906080932

Sender of MT565 DEPORUMM
Receiver of MT565 BROCKRUMM

Message structure:

:16R:GENL
:20C::CORP//MIA8614
:20C::SEME//LAGUYU0906080932
:23G:NEWM
:22F::CAEV//PRIO
:16R:LINK
:13A::LINK//564
:20C::RELA//LAGUYU0905181454
:16S:LINK
:16S:GENL
:16R:USECU
:35B:ISIN RU000A0JPKH7
RUSGIDRO, AOI or JSCRUSHYDRO
:16R:ACCTINFO
:97A::SAFE//123456
:93B::ELIG//UNIT/759696,
:16S:ACCTINFO
:16S:USECU
:16R:CAINST
:13A::CAON//001
:22F::CAOP//SECU
:36B::QINS//UNIT/40000,
:16S:CAINST

4. Accumulation of instructions, sending MT564 indicating balance of instructed position (INBA) and balance of uninstructed position (UNBA), MT567.

5. Sending to the issuer a set of documents.

a. If the purchase price of new shares is declared at once, the set of documents includes the original payment order, i.e. Payment of the Central Bank within the framework of the event is completed.

- MT 564/ACTV upon receipt of registration information report on the results of a new additional issue.

The message is sent on July 30th, 2009

MT564 – Corporate Action Notification

Corporate action reference – CA HYDR140509

Sender's reference – LAGUYU0906080936

Sender of MT564 DEPORUMM

Receiver of MT564 BROCKRUMM

Message structure:

:16R:GENL

:20C::CORP//CA HYDR140509

:20C::SEME//LAGUYU0906300936

:23G:ADDB

:22F::CAEV//PRIO

:98A::PREP//20090730

:16S:GENL

:16R:USECU

:35B:ISIN RU000A0JPKH7

RUSGIDRO, AOI

or JSC RUSHYDRO

:16R:ACCTINFO

:97A::SAFE//123456

:16S:ACCTINFO

:16S:USECU

:16R:ADDINFO

:70E::ADTX//NASTOaqIM SOOBqAEM, cTO FSFR

ZAREGISTRIROVALA OTcET OB

ITOGAH VYPUSKA I NOVYE CENNYE

BUMAGI DOSTUPNY DLa TORGOV

or

:70E::ADTX//PLEASE BE ADVISED THAT STATE

REGISTRATION OF PLACEMENT REPORT BY

FFSM. NEW SHARES IS EFFECTED ON JUNE

30 2009 AND NEW SHARES RU000A0JPKH7

/RU/1-01-55038-E-037D ARE ALLOWED

FOR CIRCULATION STARTING

JULY 01 2009 PLEASE CONTACT US

SHOULD YOU HAVE ANY QUESTION

:16S:ADDINFO

- b. If the purchase price of new shares is set after the period of prior option of purchase:
- Monitor setting of the price, sending MT564/REPL
 - Monitor transferring of funds, sending MT566/DEBT
 - Monitor depositing new shares, sending MT566/CRED indicating in field 70E:// restricting circulation of the securities before registration of the report on the results
 - MT 564/ACTV upon receipt of registration information report on the results of a new additional issue.
- c. In case the price of purchasing new shares is declared, the original of payment receipt is needed, this means that payment through Central Bank is completed.

6. After payment is made depository sends to its clients Confirmation on corporate action (:22H::CRDB//DEBT).

MT566 – Corporate Action Confirmation (money transfer)

Corporate action reference – CA HYDR140509

Sender's reference – LAGUYU0906080931

Sender of MT566 DEPORUMM

Receiver of MT566 BROCKRUMM

Message structure:

:16R:GENL

:20C::CORP//CA HYDR140509

:20C::SEME//LAGUYU0906300931

:23G:NEWM

:22F::CAEV//PRIO

:98A::PREP//20090706

:16R:LINK

:13A::LINK//564

:20C::PREV//LAGUYU09006080931

:16S:LINK

:16S:GENL

:16R:USECU

:97A::SAFE//123456

:35B:ISIN RU000A0JPKH7

RUSGIDRO, AOI

or JSC RUSHYDRO

:93B::CONB//UNIT/759696,

:16S:USECU

:16R:CADETL

:98A::EFFD//20090706

:16S:CADETL

:16R:CACONF

:13A::CAON//001

:22F::CAOP/SECU

:16R:CASHMOVE

:22H::CRDB//DEBT

:19B::PSTA//RUB40000,00

:98A::POST//20090615

:98A::VALU//20090615

:90B::PRPP//ACTU/RUB1,

:16S:CASHMOVE

:16S:CACONF

7. After receiving information on depositing of new securities (statement from the registrar), the depository sends to its clients Confirmation on corporate action confirming lending of securities (MT566/CRED) stating in field 70E :/ / information to ban the circulation of securities to the registration of the report on the results of the issue.

MT566 – Corporate Action Confirmation (securities depositing)

Corporate action reference – CA HYDR140509

Sender's reference – LAGUYU0906080931

Sender of MT566 DEPORUMM

Receiver of MT566 BROCKRUMM

Message structure:

:16R:GENL
:20C::CORP//CA HYDR140509
:20C::SEME//LAGUYU0906300931
:23G:NEWM
:22F::CAEV//PRIO
:98A::PREP//20090706
:16R:LINK
:13A::LINK//564
:20C::PREV//LAGUYU09006080931
:16S:LINK
:16S:GENL
:16R:USECU
:97A::SAFE//123456
:35B:ISIN RU000A0JPKH7
RUSGIDRO, AOI or JSC RUSHYDRO
:93B::CONB//UNIT/759696,
:16S:USECU
:16R:CADETL
:98A::EFFD//20090706
:16S:CADETL
:16R:CACONF
:13A::CAON//001
:22F::CAOP/SECU
:16R:SECMOVE
:22H::CRDB//CRED
:35B:ISIN RU000A0JPKH7
RUSGIDRO, AOI or JSC RUSHYDRO
:98A::POST//20090706
:16S:SECMOVE
:16S:CACONF
:16R:ADDINFO
:70E::ADTX//'NASTOaqIM SOOBqAEM, cTO NOVYE
AKCII ZAPREqENY K OBRAqENIu DO
REGISTRACII OTcETA OB ITOGAH
VYPUSKA V FSFR.
OR
PLEASE BE ADVISED THAT NEW SHARES
ARE NOT ALLOWED FOR CIRCULATION
BEFORE STATE REGISTRATION OF PLACEMENT
REPORT BY FFSM. PLEASE
CONTACT US SHOULD YOU HAVE ANY

QUESTIONS.
:16S:ADDINFO

MT566 – Corporate Action Confirmation

Corporate action reference – CA HYDR140509
Sender's reference – LAGUYU0906080932

Sender of MT566 DEPORUMM
Receiver of MT566 BROCKRUMM

Message structure:

:16R:GENL
:20C::CORP//CA HYDR140509
:20C::SEME//LAGUYU0906300932
:23G:NEWM
:22F::CAEV//PRIO
:98A::PREP//20090706
:16R:LINK
:13A::LINK//564
:20C::PREV//LAGUYU09006080931
:16S:LINK
:16S:GENL
:16R:USECU
:97A::SAFE//123456
:35B:ISIN RU000A0JPKH7
'RUSGIDRO, AOI or JSC RUSHYDRO
:93B::CONB//UNIT/700000,
:16S:USECU
:16R:CADETL
:98A::EFFD//20090706
:16S:CADETL
:16R:CACONF
:13A::CAON//001
:22F::CAOP/SECU
:16R:SECMOVE
:22H::CRDB//CRED
:35B:ISIN RU000A0JPKH7
'RUSGIDRO, AOI or JSC RUSHYDRO
:36B::PSTA//UNIT/40000,
:98A::POST//20090706
:98A::PAYD//20090706
:16S:SECMOVE
:16S:CASHMOVE
:22H::CRDB//DEBT
:19B::PSTA//RUB400000,00
:98A::POST//20090615
:98A::VALU//20090615
:98B::FDDT/UKWN
:90B::PRPP/ACTU/RUB1,

:16S:CASHMOVE
:16S:CACONF
:16R:ADDINFO
:70E::ADTX//”NASTOaqIM SOOBqAEM, cTO NOVYE
AKCII ZAPREqENY K OBRAqENIu DO
REGISTRACII OTcETA OB ITOGAH
VYPUSKA V FSFR.
OR
PLEASE BE ADVISED THAT NEW SHARES
ARE NOT ALLOWED FOR CIRCULATION
BEFORE STATE REGISTRATION OF PLACEMENT
REPORT BY FFSM. PLEASE
CONTACT US SHOULD YOU HAVE ANY
QUESTIONS.
:16S:ADDINFO

5.1.6. Example 6. Corporate Action Type – Repurchase from the shareholders their equities by the persons who owns more than 95% of the voting shares. (corporate action event indicator – TEND)

Definition:

An offer to shareholders, usually from a third party to sell (on a tender) or exchange their shares.

Initial terms:

Acquisition from the shareholders their equities by the persons who obtains more than 95% of the voting shares (article 84.8 of the Federal Law “Company Law”).

-Issuer – OAO “uJNAa GTK-8”

Details of issue:

common stock

ISIN RU000A0JNG48

State registration date May 19th 2005

National state registration number 1-01-34308-E

date as of which the list of holders whose securities are redeemed, registry blocking-08.05.2009

Details of the purchase:

Buyer – OOO “LUKOiL-VOLGOGRADNEFTEPERERABOTKA”

Price – 0,0398 rubles for one share

deadline for accepting applications from shareholders on the transfer of funds – 08.05.2009

Currency of payment – Russian ruble

Period of transferring securities – within 3 working days from the moment of receiving set of documents from the Issuer

In case a shareholder is not provided an order indicating the bank details or mailing address for money transfer of repurchased shares, funds will be transferred to the notary deposit.

Additional terms:

Safekeeping account number: 123456
Safekeeping account - 123456
Quantity of securities to 15.04.2009: 1000000
Quantity of securities on the date of the listing of registered persons: 1.000.000
Date of receiving by the depository information on the event and the documents, which are to be send to the clients – 15.04.2009
Deadline of instruction to the depository – 15.06.2009

1. Notification of the possibility to send OOO “LUKOIL-VOLGOGRADNEFTEPERERABOTKA” an order indicating the bank details or for money transfer.

Sender's reference – SQUE8
Corporate action reference SQUE

MT564 – Corporate Action Notification

Sender of MT564 DEPORUMM
Receiver of MT564 BROCKRUMM

Message structure:

:16R:GENL
:20C::CORP//SQUE
:20C::SEME//SQUE8
:23G:NEWM
:22F::CAEV//TEND
:22F::CAMV//CHOS
:98A::PREP//20090415
:25D::PROC//COMP
:16S:GENL
:16R:USECU
:35B:ISIN RU000A0JNG48
/RU/1-01-34308-E
'uJNAa GK TGK-8, AOI or OJSC
SOUTHERN GC TGK-8
ORD SHS 01
:16R:ACCTINFO
:97A::SAFE//123456
:93B::ELIG//UNIT/1000000,
:16S:ACCTINFO
:16S:USECU
:16R:CADETL
:98A::ANOU//20090415
:98A::RDTE//20090508
:98B::PAYD//UKWN
:90B::OFFR//ACTU/RUB0,0398
:22F::OFFE//SQUE
:70E::TXNR//MAND PURCHASE
OFFER OF OJSC SOUTHERN
GK TGK-8 ORDINARY STOCKS BY LLC

LUKOIL-VOLGOGRADNEFTEPERERABOTKA
WHICH HOLDS MORE THAN 95 PCT
VOTING SHARES. SHAREHOLDERS THOSE
REGISTERED ON 08.05.2009 SHALL
RECEIVE CASH IN EXCHANGE FOR
STOCKS.

:70E::OFFO//OOO LUKOIL-VOLGOGRADNEFTEPERERABOTKA

:16S:CADETL

:16R:CAOPTN

:13A::CAON//001

:22F::CAOP//CASH

:17B::DFLT//N

:98A::RDDT//20090501

:98A:: MKDT//20090508

:70E::ADTX//SREDSTVA O VYKUPA BUDUT

NAPRAVLENY NA UKAZANNYI

ScET ILI POcTOVYi ADRES

VLADELXCA

20090508

or

:70E::ADTX//CASH FUNDS SHALL BE

TRANSFERRED TO THE BANK

ACCOUNT OR POST ADDRESS

SPECIFIED BY A SHARE HOLDER

:16S:CAOPTN

:16R:CAOPTN

:13A::CAON//002

:22F::CAOP//NOAC

:17B::DFLT//Y

:70E::ADTX//SREDSTVA BUDUT PEREDANY

NA DEPOZIT NOTARIUSU

or

:70E::ADTX//CASH PROCEEDS SHALL BE

TRANSFERRED TO THE NOTARY

SET FORTH IN THE OFFER

:16S:CAOPTN

:16R:ADDINFO

:70E::ADTX//A HOLDER MAY FORWARD AN APPLICATION

TO LLC LUKOIL-VOLGOGRADNEFTEPERERA

BOTKA GIVING ITS BANKING DETAILS OR

POSTAL ADDRESS SHOULD BE RECEIVED

PRIOR TO 08.05.2009. IF SUCH APPLI

CATION RECEIVED AFTER 08.05.2009 OR

CONTAINS UNCOMPLETE DETAILS THE

CASH PROCEEDS SHALL FOLLOW TO THE

NOTARY SET FORTH IN

:70E::ADTX//THE OFFER.THE APPLICATION FORM,

ADDRESS FOR SENDING OF APPLICATION

AND ADDITIONAL DOCUMENTATION FOR

THE EVENT YOU MAY FIND ON THE

CUSTODY'S WEBSITE OR REQUEST FROM

YOUR ACCOUNT MANAGER.
:70E::ADTX//ALL ORDINARY STOCKS OF OJSC
SOUTHERN GC TGC-8 SHALL BE BLOCKED
STARTING FROM 08.05.2009
:70E::PACO//CORPORATE ACTIONS/REORG/DIVIDENDS
FOR QUESTIONS PLS CONTACT CUSTODY
CORP ACTIONS TEL +7 495 725 76 97
:16S:ADDINFO

2. Notification of the list of shareholders whose shares will be purchased (MT564/SQUE/REPL/).

In general, the depository account and/or the number of shares on deposit account may differ from those data, which were at the time of sending the first message.

MT564 – Corporate Action Notification

Sender's reference – SQUE85
Corporate action reference - SQUE

Sender of MT564 DEPORUMM
Receiver of MT564 BROCKRUMM

Message structure:

:16R:GENL
:20C::CORP//SQUE
:20C::SEME//SQUE85
:23G:REPL
:22F::CAEV//TEND
:22F::CAMV//MAND
:98A::PREP//20090509
:25D::PROC//COMP
:16R:LINK
:20C::PREV//SQUE8
:16S:LINK
:16S:GENL
:16R:USECU
:35B:ISIN RU000A0JNG48
/RU/1-01-34308-E
'uJNAa GK TGC-8, AOI or OJSC
SOUTHERN GK TGC-8
ORD SHS 01
:16R:ACCTINFO
:97A::SAFE//123456
:93B::ELIG//UNIT/1000000,
:93B::BLOK//UNIT/1000000,
:16S:ACCTINFO
:16S:USECU
:16R:CADETL
:98A::ANOU//20090415
:98A::RDTE//20090508

:90B::OFFR//ACTU/RUB0,0398
 :22F::OFFE//SQUE
 :70E::OFFO//'OOO LUKOIL-VOLGOGRADNEFTEPERERABOTKA
 :16S:CADETL
 :16R:CAOPTN
 :13A::CAON//001
 :22F::CAOP//CASH
 :17B::DFLT//Y
 :69A::PWAL//20090508/20090602
 :16R:SECMOVE
 :22H::CRDB//DEBT
 :35B:ISIN RU000A0JNG48
 :98B::PAYD//UKWN
 :16S:SECMOVE
 :16R:CASHMOVE
 :22H::CRDB//CRED
 :98B::PAYD//UKWN
 :16S:CASHMOVE
 :16S:CAOPTN
 :16R:ADDINFO
 :70E::ADTX//'NASTOaqIM SOOBqAEM, cTO VAQI CENNYE
 BUMAGI ZABLOKIROVANY V CELaH
 VYKUPA. SREDSTVA OT PRODAJI CENNYH
 BUMAG OJIDAuTSa V TEcENII 25 DNEi S
 DATY SOSTAVLENIa SPISKA VLADELXCEV
 or
 :70E::ADTX//PLEASE BE ADVISED THAT YOUR
 POSITION IS BLOCKED FOR SQUEEZE-OUT
 CASH PROCEEDS ARE EXPECTED WITHIN
 25 DAYS FROM RDTE
 :70E::PACO//CORPORATE ACTIONS/REORG/DIVIDENDS
 FOR QUESTIONS PLS CONTACT CUSTODY
 CORP ACTIONS TEL +7 495 725 76 97
 :16S:ADDINFO

In addition it is possible to send MT544 and MT546 blocking shares on the safekeeping account.

3. Completion of corporate action – upon receipt of notification from the registrar on securities book out based on corporate action the depository sends to its clients corporate action Confirmation stating securities book out from depo account (MT566).

Money transferred by entity who bought out the securities directly to the account of the client (the postal address), or deposit the notary. Upon notification on securities book out from the registrar based on corporate action securities are booked out to depository from the client's account. Confirmation on corporate action is sent to the account owner. Information about the cash flows in the confirmation is not indicated.

The securities under corporate action - ISIN RU000A0JNG48

MT566 – Corporate Action Confirmation

Corporate action reference - SQUE

Sender's reference – SQUE91

Message reference MT564 – FDIW/MSNG/50

Sender of MT566 DEPORUMM

Receiver of MT566 BROCKRUMM

Message structure:

:16R:GENL
:20C::CORP//SQUE
:20C::SEME//SQUE91
:23G:NEWM
:22F::CAEV//TEND
:98A::PREP//20090525
:16R:LINK
:13A::LINK//564
:20C::PREV//SQUE85
:16S:LINK
:16S:GENL
:16R:USECU
:97A::SAFE//123456
:35B:ISIN RU000A0JNG48
:93B::CONB//UNIT/1000000,
:16S:USECU
:16R:CADETL
:98A::EFFD//20090706
:16S:CADETL
:98A::RDTE//20090508
:70E::OFFO/'OOO LUKOIL-VOLGOGRADNEFTEPERERABOTKA
:16S:CADETL
:16R:CACONF
:13A::CAON//001
:22F::CAOP/CASH
:16R:SECMOVE
:22H::CRDB//DEBT
:35B:ISIN RU000A0JNG48
:36B::PSTA//UNIT/1000000,
:98A::POST//20090524
:16S:SECMOVE
:16R:CASHMOVE
:22H::CRDB//CRED
:19B::PSTA//RUB39800,
:98B::PAYD//UKWN
:98A::VALU//UKWN
:90B::OFFR/ACTU/RUB0,0398
:16S:CASHMOVE

:16S:CACONF
:16R:ADDINFO
:70E::ADTX//CASH PROCEEDS WERE SENT IN
ACCORDANCE WITH A SHAREHOLDER'S
APPLICATION IF THE SHAREHOLDER
HAD SUBMITTED TO LLC LUKOIL-
VOLGOGRADNEFTEPERERABOTKA AN
APPLICATION WITH BANKING DETAILS
OR POSTAL ADDRESS PRIOR TO
08.05.2009, IN OTHER CASES CASH
PROCEEDS WERE SENT TO THE
DEPOSIT OF THE NOTARY
:70E::PACO//ATT CORP ACTIONS
FOR INQUIRIES PLEASE CONTACT
RB SEC SERVICES CORP ACTIONS
:16S:ADDINFO

5.1.7. Example 7. Corporate Action Type – Booking out of worthless securities due to liquidation of the issuer (corporate action event indicator – WRTH)

Definition:

Booking out of worthless securities.

-Issuer – OAO “FOND DOLGOSROcNYH SBEREJENi”

Security – common stock

common stock

ISIN RU0009843247

State registration date 07.09.2000

National state registration number 1-06-30039D

Sender’s reference – FDIW/MSNG/50

Corporate action reference WRTHFDI123

Corporate action securities - OAO “FOND DOLGOSROcNYH SBEREJENi” ISIN
RU0009843247

Type of corporate event - Booking out of valueless securities

1. Upon receipt of information on corporate action of booking out of worthless securities the depository sends to its clients Notification on corporate action (MT564/NEWM/WRTH).

MT564 – Corporate Action Notification

Corporate action reference WRTHFDI123

Sender’s reference – FDIW/MSNG/50

Sender of MT564 DEPORUMM

Receiver of MT564 BROCKRUMM

Message structure:

:16R:GENL
:20C::CORP//WRTHFDI123
:20C::SEME//FDIW/MSNG/50
:23G:NEWM
:22F::CAEV//WRTH
:16S:GENL
:16R:USECU
:35B:ISIN RU0009843247
/RU/1-06-30039-D
'OAO FOND DOLGOSROcNIH SBEREJENII
:16R:ACCTINFO
:97A::SAFE//123456
:93B::ELIG//UNIT/63,
:16S:ACCTINFO
:16S:USECU
:16R:CADETL
:98A::RDTE//20081014
:16S:CADETL
:16R:CAOPTN
:13A::CAON//001
:22H::CAOP//OTHR
:16R:SECMOVE
:22H::CRDB//DEBT
:35B:ISIN RU0009843247
'OAO FOND DOLGOSROcNIH INVESTICIi
:36B::PSTA//UNIT/63,
:98A::POST//20090226
:98A::VALU//20080701
:16S:SECMOVE
:16S:CAOPTN
:16R:ADDINFO
:70E::TXNR//AS A RESULT OF LIQUIDATION
OF ISSUER OAO FOND DOLGOSROCNIH SBEREJENII
:70E::PACO//SHOULD YOU HAVE ANY QUESTIONS
PLEASE CONTACT
NAME PETROVA MARIA
TEL 7 495 241 43 44
FAX 7 495 916 38 41
EMAIL PETROVA AT DEPO.RU
:16S:ADDINFO

2. Upon receipt from the registrar of the report on results of booking out of worthless securities based on liquidation of the issuer in the registrar the depository sends Confirmation on the corporate action (MT566)/

Upon receipt of report from the registrar on the results of booking out of worthless securities based on liquidation of the issuer in the registrar the depository (BIC DEPORUMM) reflects the operation and sends to the account owner ABC Broker (BIC BROKRUMM) confirmation which contains confirmation of the corporate action for depo

account 123456 on the securities of 'OAO FOND DOLGOSROcNIH SBEREJENII ISIN RU0009843247.

Sender's reference – FDIW/MSNG/51

Corporate action reference WRTHFDI123

MT564 message reference – FDIW/MSNG/50

Corporate action securities - OAO "FOND DOLGOSROcNYH SBEREJENII" ISIN RU0009843247

Corporate action type – booking out of worthless securities

Date of operation in registrar – October 14th, 2008

Date of operation in custody – February 26, 2009

MT566 – Corporate Action Confirmation

Corporate action reference WRTHFDI123

Sender's reference – FDIW/MSNG/51

Sender of MT566 DEPORUMM

Receiver of MT566 BROCKRUMM

Message structure:

:16R:GENL

:20C::CORP//WRTHFDI123

:20C::SEME//FDIW/MSNG/51

:23G:NEWM

:22F::CAEV//WRTH

:16R:LINK

:13A::LINK//564

:20C::PREV//FDIW/MSNG/50

:16S:LINK

:16S:GENL

:16R:USECU

:97A::SAFE//123456

:35B:ISIN RU0009843247

/RU/1-06-30039-D

'OAO FOND DOLGOSROcNIH SBEREJENII

:93B::CONB//UNIT/63,

:16S:USECU

:16R:CADETL

:98A::RDTE//20081014

:16S:CADETL

:16R:CACONF

:13A::CAON//001

:22H::CAOP//OTHR

:16R:SECMOVE

:22H::CRDB//DEBT

:35B:ISIN RU0009843247

'OAO FOND DOLGOSROcNIH INVESTICI

:36B::PSTA//UNIT/63,

:98A::POST//20090226

:98A::VALU//20080701
:16S:SECMOVE
:16S:CACONF
:16R:ADDINFO
70E::TXNR//AS A RESULT OF LIQUIDATION
OF ISSUER OAO FOND DOLGOSROCNIH SBEREJENII
:70E::PACO//SHOULD YOU HAVE ANY QUESTIONS
PLEASE CONTACT
NAME PETROVA MARIA
TEL 7 495 241 43 44
FAX 7 495 916 38 41
EMAIL PETROVA AT DEPO.RU
:16S:ADDINFO

5.1.8. Example 8. Corporate Action Type – Compilation a list of shareholders to participate in the shareholder’s meeting (corporate action event indicator – DSCL)

Definition:

The requirement to the holders or owners to disclose to the issuer the name, location and the balances of all issues.

In accordance with this recommendations the request may be sent by nominees and trustees for a list of shareholders to participate in the meeting, payment of dividends, as well as in cases where, in accordance with applicable law, the list of shareholders is prepared.

Initial terms:

-Issuer – OAO “AKCIONERNAa FINANSOVAa KORPORACIa “SISTEMA”

Details of issue:

common stock

ISIN RU000A0DQZE3

International state registration number (assigned by FCSM) – 1-04-01669-A

state registration date July 8th 2004

OAO “AKCIONERNAa FINANSOVAa KORPORACIa “SISTEMA”, location: Russian Federation, 125009, Moscow, Mohovaya st., 13 building 1, announced holding of AGM OAO AFK “SISTEMA” (joint presence of shareholders to vote on the issues) mailing proxy forms in advance.

AGM – event type – MEET.

Prior to the meeting of shareholders a list of equity owners should be compiled.

Registrar fixation date (the date of listing shareholders): 15 May 2010 (close).

Date of the meeting June 26th, 2010 11:00 Moscow time.

Additional terms:

Safekeeping account number: 123456

Safekeeping account - 123456

Quantity of securities at the nominee holder account to the listing date of the registered persons: (July 28th 2008) – 23063 (common stock).

When carrying out this corporate action nominee holder is sent two corporate action notifications.

This is an example of notification sent by the depository (BIC DEPORUMM) to the nominee holder ABC BROKER (BIC BROKRUMM) and contains information on corporate action (AGM) on safekeeping account 123456 on OAO "AKCIONERNAa FINANSOVAa KORPORACIa "SISTEMA" securities ISIN RU000A0DQZE3
The rules of financial instrument's indication are defined in section 1.8.5 of this document.

1. AGM notification is formed by the depository and contains information on corporate action details:

-AGM

Reference number of the message on AGM (sender's reference) - AE79HC/080723/50

Reference number of the request message for list of owners due to AGM (sender's reference) - AE79HC/080723/50

Corporate action reference – RAO123

Date and time – April 30th 2008, 18:30

Full information is provided (ROC/COMP).

MT564 – Corporate Action Notification

Corporate action reference – RAO123

Sender's reference – AE79HC/080723/50

Sender of MT564 DEPORUMM

Receiver of MT564 BROCKRUMM

Message structure:

:16R:GENL

:20C::CORP//AFK123

:20C::SEME//AFKMEET2008123001

:23G:NEWM

:22F::CAEV//MEET

:22F::CAMV//VOLU

:98A::PREP//20080430

:25D::PROC//COMP

:16S:GENL

:16R:USECU

:35B:ISIN RU000A0DQZE3

'AFK SISTEMA, AO

:16R:ACCTINFO

:97A::SAFE//123456

or

– if notification is provided to all accounts opened in depository, it is possible to use
GENR

:97C::SAFE//GENR in this case balance is not shown in notification

:93B::SETT//UNIT/23063,

:93B::ELIG//UNIT/23063, or once :93C::SETT//UNIT/ELIG/23063,

:16S:ACCTINFO

:16S:USECU

:16R:CADETL

:98A::RDTE//20080515

:98C:MEET//20080628110000

:16S:CADETL
:16R:ADDINFO
:70E::PACO//FOR ALL QUESTIONS PLEASE
CONTACT PERSON
TEL (123) 456-78-90
E-MAIL XXXXXX (AT)XXXXXX
:16S:ADDINFO

Request to disclose beneficial owners and to present shareholder's list

Market deadline – May 21st 2010

Deadline – May 20th 2010

MT564 – Corporate Action Notification

Corporate action reference – AFK456

Sender's reference – AFKDCL2008123001

Sender of MT564 DEPORUMM

Receiver of MT564 BROCKRUMM

Message structure:

:16R:GENL
:20C::CORP//AFK456
:20C::SEME//AFKDSCL2008123001
:23G:NEWM
:22F::CAEV//DSCL
:22F::CAEP//GENL
:22F::CAMV//MAND
:98A::PREP//20100516
:25D::PROC//COMP
:16R:LINK
:13A::LINK//564
:20C::PREV// AE79HC/080723/50
:16S:LINK
:16S:GENL
:16R:USECU
:35B:ISIN RU000A0DQZE3
'AFK SISTEMA, AO
:16R:ACCTINFO
:97A::SAFE//123456
:93B::SETT//UNIT/23063,
:93B::ELIG//UNIT/23063, or once :93C::SETT//UNIT/ELIG/23063,
:16S:ACCTINFO
:16S:USECU
:16R:CADETL
:98A::RDTE//0100515
:98C::MEET//20100626110000
:16S:CADETL
:16R:ADDINFO
:16R:CAOPTN
:13A::CAON//001

:22F::CAOP//OTHR
:17B::DFLT//Y
:98A::RDDT//20090520
:98A::MKDT//20100521
:16S:CAOPTN
:16R:ADDINFO
:70E::ADTX//’SOSTAVLENIE SPISKA VLADELcEV K
GODOVOMu SOBRANiu AKCIONEROV’
or
:70E::ADTX//DRAW UP OF LIST OF BENEFICIAL
OWNERSHIP FOR ANNUAL GENERAL MEETING
:70E::PACO//FOR ALL QUESTIONS PLEASE
CONTACT PERSON NAME
TEL (0123) 456-78-90
E-MAIL XXXXXX (AT) XXXXXXXX
:16S:ADDINFO

Request to render shareholder’s list

MT564 – Corporate Action Notification

Corporate action reference – AFK456
Sender’s reference – AFKDCL2008123001

Sender of MT564 DEPORUMM
Receiver of MT564 BROCKRUMM

Message structure:

:16R:GENL
:20C::CORP//AFK456
:20C::SEME//AFKDSCL2008123001
:23G:NEWM
:22F::CAEV//DSCL
:22F::CAEP//GENL
:22F::CAMV//VOLU
:98A::PREP//20100516
:25D::PROC//COMP
:16R:LINK
:13A::LINK//564
:20C::PREV//AE79HC/080723/50
:16S:LINK
:16S:GENL
:16R:USECU
:35B:ISIN RU000A0DQZE3
/RU/1-04-01669-A
‘AFK SISTEMA, AO
:16R:ACCTINFO
:97A::SAFE//123456
:93B::SETT//UNIT/23063,
:93B::ELIG//UNIT/23063, or once :93C::SETT//UNIT/ELIG/23063,
:16S:ACCTINFO

:16S:USECU
:16R:CADETL
:98A::RDTE//20100515
:98C::MEET//20100626110000
:16S:CADETL
:16R:CAOPTN
:13A::CAON//001
:22F::CAOP//CONY
:17B::DFLT//N
:98A::RDDT//20100520
:98A::MKDT//20100521
:16S:CAOPTN
:16R:CAOPTN
:13A::CAON//002
:22F::CAOP//CONN
:17B::DFLT//Y
:98A::MKDT//20100521
:98A::RDDT//20100520
:16S:CAOPTN
:16R:CAOPTN
:13A::CAON//003
:22F::CAOP//NOAC
:17B::DFLT//Y
:98A::RDDT//20090520
:16S:CAOPTN
:16R:ADDINFO
:70E::ADTX//DRAW UP OF LIST OF BENEFICIAL
OWNERSHIP UPON ISSUERS REQUEST
:70E::PACO//FOR ALL QUESTIONS PLEASE
CONTACT PERSON NAME
TEL (0123) 456-78-90
E-MAIL XXXXXX (AT) XXXXXXXX
:16S:ADDINFO

CORPORATE ACTION EVENT INDICATORS

Code	Designation	Description	Comments	Legal documents
ACTV	Trading Status: Active	Trading in security has commenced or security has been re-activated after a suspension in trading.	<ol style="list-style-type: none"> 1. Sent after the start of trading in the context of Issuance report registration. 2. Resumption of trading after suspension (see SUSP). 3. If the company is derived from bankruptcy (ISIN didn't change) Reason: Issuance report registration, the flow of information from the Registrar 	"Standards for Securities Issuance and Prospectus Registration" Order of FFMS 25.01.2007 № 07-4/pz-n
BIDS	Repurchase Offer/ Issuer Bid/Reverse Rights	Offer to existing shareholders by the issuing company to repurchase equity or other securities convertible into equity. The objective of the offer is to reduce the number of outstanding equities.	<ol style="list-style-type: none"> 1. Repurchase of own shares by the issuer in order to reduce registered capital. 2. Redemption of shares by the joint-stock company on request of the shareholders, section 75-76 of "Company law". Reason: <ul style="list-style-type: none"> - Notification of the issuer of redemption, - Message on the results of the meeting 	Federal Law "Company law", 24.11.1995 №208-FZ, section 29, 75-76
BONU	Bonus Issue/ Capitalisation Issue	Bonus, scrip or capitalisation issue. Security holders receive additional assets free of payment from the issuer, in proportion to their holding.	Increase registered capital. Proportionment of the additional shares of the same issuer among shareholders. Reason: Placement of additional share issue amid all existing shareholders.	Federal Law "Company law", 24.11.1995 №208-FZ, section 28
BPUT	Put Redemption	Early redemption of a security at the election of the holder subject to the terms and condition of the issue	Irrevocable offer for bonds Reason: 1. Bonds. The possibility of early redemption in accordance with the decision on the issue.	<ol style="list-style-type: none"> 1. Bonds issue decision 2. Issue decision, "Standards for Securities Issuance and Prospectus

			2. Bonds convertible into shares on the request of bondholders	Registration" Order of FFMS 25.01.2007 № 07-4/pz-n p.6.1.4, Federal Law "Company law", 24.11.1995 №208-FZ, section 33, p.3
BRUP	Bankruptcy	Legal status of a company unable to pay creditors. Bankruptcy usually involves a formal court ruling. Securities may become valueless.	Bankruptcy notification. The notification is sent upon receipt the information on the bankruptcy process.	Federal Law "Bankruptcy act" 26.10.2002 №127-FZ
CHAN	Change	Information regarding a change further described in the corporate action details.	Information regarding any changes further described in CADETL 1. Changing the name (other personal data) of the issuer / tool. 2. Assignment the shares state registration code at the initial offering 3. Changes in the parameters of the issue 4. Sometimes replacing the old number with a new of the state omission by the Registrars performed without securities transaction. 5. Other than changes in the CD, SWIFTs that need to be filled with earlier sent reference with the same CAEV and:: 23: REPL Change Par - REDO	
CONS	Consent	Procedure that aims to obtain consent of holder to a proposal by the issuer or a third party intended to progress an event to the next stage. This procedure is not required to be linked to	1. Offer a meeting to bondholders to discuss issues of debt restructuring and execution of appropriate agreements. 2. Meeting representatives of the issuer with the owners.	

		the organisation of a formal meeting. For example, consent to approve a plan of reorganisation for a bankruptcy proceeding.		
CONV	Conversion	Conversion of securities (generally convertible bonds or preferred shares) into another form of securities (usually common shares) at a pre-stated price/ratio.	Issue conversion (conversion of the preferred shares into common stock, conversion of bonds into shares, conversion of preferred shares of one type into preferred stock of another type, conversion of options into shares).	Federal Law "Company law", 24.11.1995 №208-FZ, "Standards for Securities Issuance and Prospectus Registration" Order of FFMS 25.01.2007 № 07-4/pz-n
DECR	Decrease in Value	Reduction of face value. The number of circulating shares remains unchanged. This event may include a cash payout to holders.		Federal Law "Company law", 24.11.1995 №208-FZ, "Standards for Securities Issuance and Prospectus Registration" Order of FFMS 25.01.2007 № 07-4/pz-n
DFLT	Bond Default	Failure by the company to perform obligations defined as default events under the bond agreement and that have not been remedied.	Notification of default on the bonds. Reason for sending the message - formal notification of the decision made by the competent authority or in accordance with the terms set out in decision of the issue.	
DLST	Trading Status: Delisted	Security is no longer able to comply with the listing requirements of a stock exchange and is removed from official board quotation.	Exclusion of securities from listing. Reason for sending the message - information received from the Stock Exchange	
DSCL	Disclosure	Requirement for holders or	Disclosure to the nominee. The request for	

		beneficial owners to disclose their name, location and holdings of any issue to the issuer.	disclosure of beneficial owners and to prepare the owners list. Typically, disclosure on the bonds is available in free form or a link to a site is provided where the necessary forms are to be filled.	
DTCH	Dutch Auction	An action by a party wishing to acquire a security. Holders of the security are invited to make an offer to sell, within a specific price range. The acquiring party will buy from the holder with lowest offer.	Dutch Auction	
DVCA	Cash Dividend	Distribution of cash to shareholders, in proportion to their equity holding. Ordinary dividends are recurring and regular. Shareholder must take cash and may be offered a choice of currency.		
DVSE	Stock Dividend	Dividend paid to shareholders in the form of equities of the issuing corporation.	Payment of dividends in the form of shares of the issuing company	
EXOF	Exchange	Exchange of holdings for other securities and/or cash. The exchange can be either mandatory or voluntary involving the exchange of outstanding securities for different securities and/or cash. For example "exchange offer",	For bonds convertible into shares: At maturity (the calendar date, time period or event that must inevitably occur), with the circumstances specified in the decision bonds placement	Order of the Ministry of Finance 19.08.2004 №68n "Approval conditions of the issue terms and trading state savings bonds"

		"capital reorganisation" or "funds separation".		
INCR	Increase in Value	Increase in the face value of a single security. The number of circulating securities remains unchanged.		Federal Law "Company law", 24.11.1995 №208-FZ, "Standards for Securities Issuance and Prospectus Registration" Order of FFMS 25.01.2007 № 07-4/pz-n
INTR	Interest Payment	Regular interest payment distributed to holders of an interest bearing asset.	Bonds coupon yield payment	
LIQU	Liquidation Dividend/ Liquidation Payment	A distribution of cash, assets or both. Debt may be paid in order of priority based on preferred claims to assets specified by the security.	Disbursements upon liquidation of the issuer, together with the write-off securities	Federal Law "Company law", 24.11.1995 №208-FZ, s.23
MCAL	Full Call/Early Redemption	The redemption of an entire issue outstanding of securities, for example, bonds, preferred equity, funds, by the issuer or its agent, for example, asset manager, before final maturity.	Early repayment of the whole bonds issue	
MEET	Annual General Meeting	Annual general meeting.		Federal Law "Company law", 24.11.1995 №208-FZ, Resolution of FFMS №17/ps 31.05.2002
MRGR	Merger	Exchange of outstanding securities, initiated by the issuer which may include options, as		Federal Law "Company law", 24.11.1995 №208-FZ s. 16-17, "Standards for

		the result of two or more companies combining assets, that is, an external, third party company. Cash payments may accompany share exchange.		Securities Issuance and Prospectus Registration” Order of FFMS 25.01.2007 № 07-4/pz-n s.8
OTHR	Other event	Other event, use only when no other event type applies, for example, a new event type.	Used only if other codes are not applicable	
PARI	Pari-Passu	Occurs when securities with different characteristics, for example, shares with different entitlements to dividend or voting rights, become identical in all respects, for example, pari-passu or assimilation. May be scheduled in advance, for example, shares resulting from a bonus may become fungible after a pre-set period of time, or may result from outside events, for example, merger, reorganisation, issue of supplementary tranches, etc.	Consolidated securities issue, cancellation of additional codes issue	Resolution of FFMS №07-23/pz-n (former 03-16/pz-n)
PCAL	Partial Redemption with Reduction of Nominal Value	Securities are redeemed in part before their scheduled final maturity date with reduction of the nominal value of the securities. The outstanding amount of securities will be reduced proportionally.	Partial prepayment with decrease in the face value	Bonds issue Decision

PINK	Pay In Kind	Interest payment, in any kind except cash, distributed to holders of an interest bearing asset.	In case of income payments on bonds in the form of other than cash.	p.7.3 of the issue of bonds Decision contains information on the form of payment (“Standards for Securities Issuance and Prospectus Registration” Order of FFMS 25.01.2007 № 07-4/pz-n)
PRED	Partial Redemption Without Reduction of Nominal Value	Securities are redeemed in part before their scheduled final maturity date without reduction of the nominal value of the securities. This is commonly done by pool factor reduction.	Reducing the principal without reducing the par value (pull factor)	Bonds issue Decision
PRII	Interest Payment with Principal	An event which consists of two components, the decrease of the amortized value of a pool factor security and an interest payment.	Partial repayment of par value (government bond). Bonds coupon yield payment +partial repayment of principal	Bonds issue Decision
PRIO	Priority Issue	Form of open or public offer where, due to a limited amount of securities available, priority is given to existing shareholders.	Implementation of pre-emptive rights. Reason: Pre-emptive right to acquisition of additional shares issue: 1. all shareholders with public subscription; 2. voted against and those who didn't vote – traded privately. 3. In Company - pre-emptive right for acquisition of shares by the shareholder, sold by another shareholder	Federal Law “Company law”, 24.11.1995 №208-FZ
REDM	Final Maturity	The redemption of an entire issue outstanding of securities,	Redemption of bonds in a target date maturity	

		for example, bonds, preferred equity, funds, by the issuer or its agent, for example, asset manager, at final maturity.		
REDO	Redenomination	Event by which the unit (currency and/or nominal) of a security is restated, for example, nominal/par value of security in a national currency is restated in another currency.	Change in face value due to: 1.Currency denomination 2.Currency change	Resolution of FFMS 20.04.1998 №6 “Changing decision on the issue of securities, prospectuses securities, plans for privatization and founding documents associated with changes of face value of the Russian banknotes and scale of prices”
SOFF	Spin-Off	A distribution of subsidiary stock to the shareholders of the parent company without a surrender of shares. Spin-off represents a form of divestiture usually resulting in an independent company or in an existing company. For example, demerger, distribution, unbundling.	Reorganization in the form of spin-off or separation	Federal Law “Company law”, 24.11.1995 №208-FZ, p.18-19 “Standards for Securities Issuance and Prospectus Registration” Order of FFMS 25.01.2007 № 07-4/pz-n
SPLF	Stock Split/Change in Nominal Value/ Subdivision	Increase in a corporation's number of outstanding equities without any change in the shareholder's equity or the aggregate market value at the time of the split. Equity price	simultaneous proportional reduction of the face value of shares with an increase in the number of shares (split)	Federal Law “Company law”, 24.11.1995 №208-FZ, p.74 “Standards for Securities Issuance and Prospectus Registration” Order of

		and nominal value are reduced accordingly.		FFMS 25.01.2007 № 07-4/pz-n
SPLR	Reverse Stock Split/Change in Nominal Value	Decrease in a company's number of outstanding equities without any change in the shareholder's equity or the aggregate market value at the time of the split. Equity price and nominal value are increased accordingly.	simultaneous proportional increase of the face value of shares with a simultaneous decrease in the number of shares	Federal Law "Company law", 24.11.1995 №208-FZ, p.74 "Standards for Securities Issuance and Prospectus Registration" Order of FFMS 25.01.2007 № 07-4/pz-n
SUSP	Trading Status: Suspended	Trading in the security has been suspended.	Suspension of trading: issuer decision; upon court order etc	Issuer decision; upon court order etc
TEND	Tender/Acquisition/ Takeover/Purchase Offer/Buyback	An offer made to shareholders, normally by a third party, requesting them to sell (tender) or exchange their equities.	1. Mandatory or voluntary offer for shares redemption 2. Shares redemption by a person who has acquired 95% of stake 3. Instant redemption of bonds by the issuer without redemption	Federal Law "Company law", 24.11.1995 №208-FZ, p.84.1-84.2, 84.7-84.8 "Standards for Securities Issuance and Prospectus Registration" Order of FFMS 25.01.2007 № 07-4/pz-n Federal Law "Securities Market"
TREC	Tax Reclaim	Event related to tax reclaim activities.	Order of the owner to the Depository for tax refund	
WRTH	Worthless	Booking out of valueless securities.	Liquidation of the issuer, booking out of valueless securities. The reason can be: an extract from the USRLE on the termination or liquidation or excerpt from the safekeeping place on the booking out of the securities of	"Civil Code of the Russian Federation", Resolution of the FFMS 02.10.1997 №27 "On Approval of The provisions of the

			the liquidated issuer	administration of share Registrar"
WTRC	Withholding Tax Relief Certification	Certification request for withholding tax reduction or exemption based on the tax status of the holder.	Request for documents for tax reclaim	
XMET	Extraordinary or Special General Meeting	Extraordinary or special general meeting.		Federal Law "Company law", 24.11.1995 №208-FZ, p.47

2089500